



Catalog

# Low voltage Industrial performance motors

We provide motors and generators, services and expertise to save energy and improve customers' processes over the total lifecycle of our products, and beyond.



# Low voltage Industrial performance motors Sizes 63 to 400, 0.12 to 630 kW

04	General information
07	General technical specification
13	Aluminum motors
14	Mechanical design
24	Rating plates
25	Ordering information
26	Technical data
30	Variant codes
35	Dimension drawings
49	Accessories
51	Aluminium motors in brief
53	Steel motors
54	Mechanical design
63	Rating plates
64	Ordering information
65	Technical data
69	Variant codes
72	Dimension drawings
82	Accessories
84	Steel motors in brief
85	Cast iron motors
86	Mechanical design
94	Rating plates
95	Ordering information
95	Technical data
100	Variant codes
104	Dimension drawings
109	Cast iron motors in brief
112	Total product offer
113	Visit our web site

ABB reserves the right to change the design, technical specification and dimensions without prior notice.

# General information

## Standards

ABB motors are of the totally enclosed and open drip proof, single or three phase squirrel cage type, built to comply with international IEC and EN standards. Motors conforming to other national and international specifications are also available on request.

All production units are certified to ISO 9001 international quality standard as well ISO 14000 environmental standard and confirm to all applicable EU Directives.

### IEC / EN

Electrical	Mechanical
IEC/EN 60034-1	IEC 60072
IEC/EN 60034-2-1	IEC/EN 60034-5
IEC/EN 60034-30	IEC/EN 60034-6
IEC 60034-8	IEC/EN 60034-7
IEC 60034-12	IEC/EN 60034-9
	IEC 60034-14

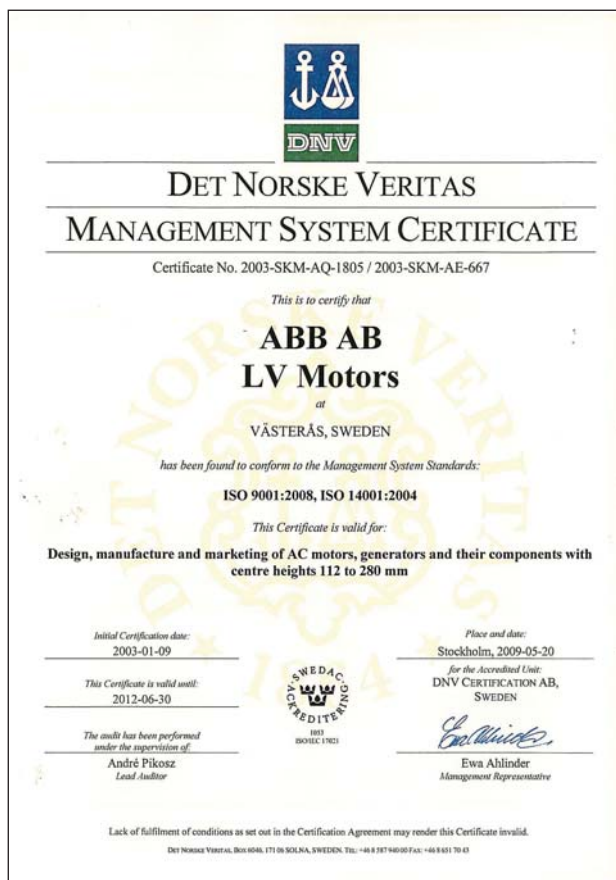

M000003



M000001

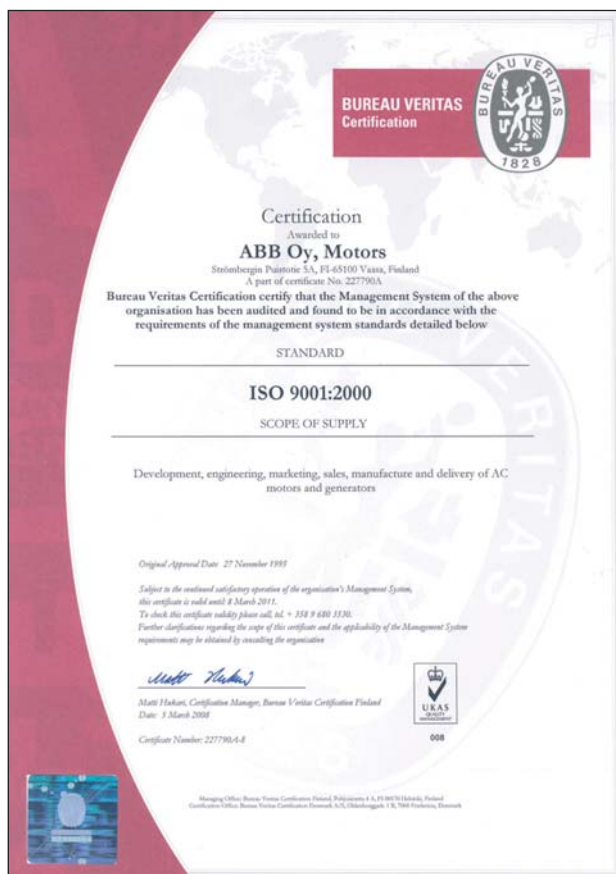

M000002

# International motor efficiency standards

A worldwide energy efficiency classification system now exists for low voltage three-phase asynchronous motors. This system increases the level of harmonization in efficiency regulations around the world.

International Electrotechnical Commission (IEC) standard IEC/EN 60034-30:2008 defines energy-efficiency (IE code) classes for single speed, three-phase, 50 and 60 Hz induction motors. The standard is part of an effort to unify motor testing procedures and efficiency and product labeling requirements to enable motor purchasers worldwide to easily recognize premium efficiency products. The efficiency levels defined in IEC/EN 60034-30 are based on test methods specified in IEC/EN 60034-2-1:2007.

## IEC/EN 60034-2-1:2007

IEC/EN 60034-2-1, which came into force in September 2007, introduces new rules concerning the testing methods to be used for determining losses and efficiency.

It offers two ways of determining efficiency; the direct and indirect methods. The standard specifies the following parameters for determining efficiency using the indirect method:

- reference temperature
- three options for determining  $P_{LL}$  (additional load losses): measurement, estimation and mathematical calculation.

The resulting efficiency values differ from those obtained under the previous IEC testing standard, IEC 60034-2:1996. It must be noted that efficiency values are only comparable if they are measured using the same method.

### Efficiency testing standard IEC/EN 60034-2-1:2007

Direct method

Indirect method:

- Measurement;  $P_{LL}$  calculated from load tests
- Estimation;  $P_{LL}$  at 2.5% – 1.0% of input power at rated load between 0.1 kW and 1000 kW
- Mathematical calculation; Eh star – alternative indirect method with mathematical calculation of  $P_{LL}$

Winding losses in stator and rotor determined at  
[25°C + actual temperature rise measured]

To promote transparency in the market, IEC 60034-30 states that both the efficiency class and efficiency value must be shown on the motor rating plate and in product documentation. The documentation must clearly indicate the efficiency testing method used as the different methods can produce differing results.

## IEC/EN 60034-30:2008

IEC/EN 60034-30:2008 defines three IE (International Efficiency) efficiency classes for single speed, three-phase, cage induction motors.

- IE1 = Standard efficiency (EFF2 in the former European classification scheme)
- IE2 = High efficiency (EFF1 in the former European classification scheme and identical to EPAct in the USA for 60 Hz)
- IE3 = Premium efficiency (identical to "NEMA Premium" in the USA for 60 Hz)
- IE4 = A future level above IE3

Efficiency levels defined in IEC/EN 60034-30 are based on test methods specified in IEC/EN 60034-2-1:2007.

Compared to the former European efficiency classes defined by the CEMEP agreement the scope has been expanded.

IEC/EN 60034-30 covers almost all motors (for example standard, hazardous area, marine, brake motors)

- Single speed, three-phase, 50 Hz and 60 Hz
- 2-, 4- or 6-poles
- Rated output from 0.75 to 375 kW
- Rated voltage  $U_N$  up to 1000 V
- Duty type S1 (continuous duty) or S3 (intermittent periodic duty) with a rated cyclic duration factor of 80 percent or higher
- Capable of operating direct online

The following motors are excluded from IEC 60034-30:

- Motors made solely for converter operation
- Motors completely integrated into a machine (for example, pump, fan or compressor) that cannot be tested separately from the machine

Minimum efficiency values defined in IEC 60034-30:2008 standard (based on test methods specified in IEC 60034-2-1:2007)

Output kw	IE1 Standard efficiency			IE2 High efficiency			IE3 Premium efficiency		
	2 pole	4 pole	6 pole	2 pole	4 pole	6 pole	2 pole	4 pole	6 pole
0.75	72.1	72.1	70.0	77.4	79.6	75.9	80.7	82.5	78.9
1.1	75.0	75.0	72.9	79.6	81.4	78.1	82.7	84.1	81.0
1.5	77.2	77.2	75.2	81.3	82.8	79.8	84.2	85.3	82.5
2.2	79.7	79.7	77.7	83.2	84.3	81.8	85.9	86.7	84.3
3	81.5	81.5	79.7	84.6	85.5	83.3	87.1	87.7	85.6
4	83.1	83.1	81.4	85.8	86.6	84.6	88.1	88.6	86.8
5.5	84.7	84.7	83.1	87.0	87.7	86.0	89.2	89.6	88.0
7.5	86.0	86.0	84.7	88.1	88.7	87.2	90.1	90.4	89.1
11	87.6	87.6	86.4	89.4	89.8	88.7	91.2	91.4	90.3
15	88.7	88.7	87.7	90.3	90.6	89.7	91.9	92.1	91.2
18.5	89.3	89.3	88.6	90.9	91.2	90.4	92.4	92.6	91.7
22	89.9	89.9	89.2	91.3	91.6	90.9	92.7	93.0	92.2
30	90.7	90.7	90.2	92.0	92.3	91.7	93.3	93.6	92.9
37	91.2	91.2	90.8	92.5	92.7	92.2	93.7	93.9	93.3
45	91.7	91.7	91.4	92.9	93.1	92.7	94.0	94.2	93.7
55	92.1	92.1	91.9	93.2	93.5	93.1	94.3	94.6	94.1
75	92.7	92.7	92.6	93.8	94.0	93.7	94.7	95.0	94.6
90	93.0	93.0	92.9	94.1	94.2	94.0	95.0	95.2	94.9
110	93.3	93.3	93.3	94.3	94.5	94.3	95.2	95.4	95.1
132	93.5	93.5	93.5	94.6	94.7	94.6	95.4	95.6	95.4
160	93.7	93.8	93.8	94.8	94.9	94.8	95.6	95.8	95.6
200	94.0	94.0	94.0	95.0	95.1	95.0	95.8	96.0	95.8
250	94.0	94.0	94.0	95.0	95.1	95.0	95.8	96.0	95.8
315	94.0	94.0	94.0	95.0	95.1	95.0	95.8	96.0	95.8
355	94.0	94.0	94.0	95.0	95.1	95.0	95.8	96.0	95.8
375	94.0	94.0	94.0	95.0	95.1	95.0	95.8	96.0	95.8

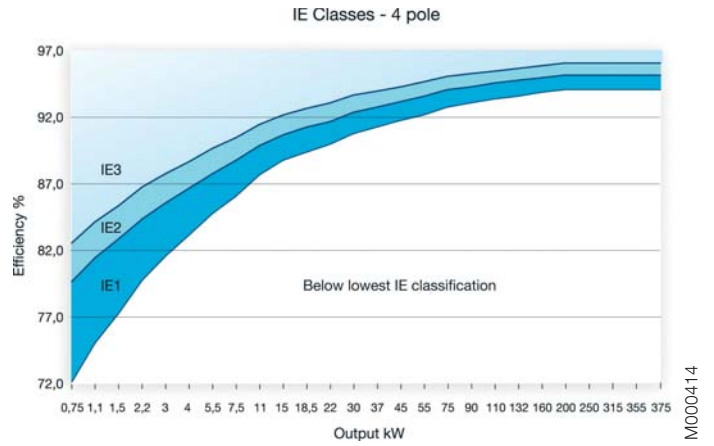

### ABB and efficiency standards

ABB determines efficiency values according to IEC/EN 60034-2-1 using the low uncertainty method i.e. indirect method, with additional load losses determined by measurement.











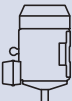
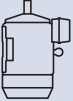
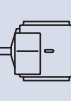
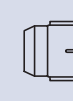
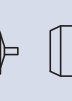
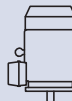
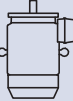
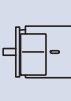
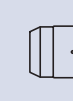
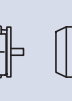

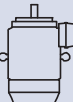
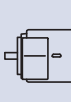
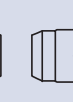
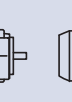

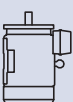
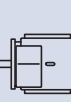
ABB has a full range of IE2 motors – with many available from stock – and a broad range of IE3 motors.

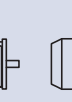
As the world market leader, ABB offers the largest range of low voltage motors available. It has long advocated the need for efficiency in motors, and high efficiency products (EFF1 in the former European classification scheme) have formed the core of its portfolio for many years.

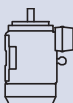
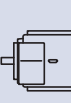
# General technical specification

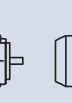
## Mechanical and electrical design

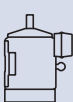
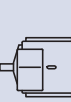
### Mounting arrangements

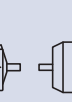
	Codel/Codell						Product code pos. 12
Foot-mounted motor.	<b>IM B3</b> <b>IM 1001</b>	<b>IM V5</b> <b>IM 1011</b>	<b>IM V6</b> <b>IM 1031</b>	<b>IM B6</b> <b>IM 1051</b>	<b>IM B7</b> <b>IM 1061</b>	<b>IM B8</b> <b>IM 1071</b>	A = foot-mounted, term.box top R = foot-mounted, term.box RHS L = foot-mounted, term.box LHS
	M000007						
Flange-mounted motor, large flange	<b>IM B5</b> <b>IM 3001</b>	<b>IM V1</b> <b>IM 3011</b>	<b>IM V3</b> <b>IM 3031</b>	*) <b>IM 3051</b>	*) <b>IM 3061</b>	*) <b>IM 3071</b>	B = flange mounted, large flange
	M000008						
Flange-mounted motor, small flange	<b>IM B14</b> <b>IM 3601</b>	<b>IM V18</b> <b>IM 3611</b>	<b>IM V19</b> <b>IM 3631</b>	*) <b>IM 3651</b>	*) <b>IM 3661</b>	*) <b>IM 3671</b>	C = flange mounted, small flange
	M000009						
Foot- and flange-mounted motor with feet, large flange	<b>IM B35</b> <b>IM 2001</b>	<b>IM V15</b> <b>IM 2011</b>	<b>IM V36</b> <b>IM 2031</b>	*) <b>IM 2051</b>	*) <b>IM 2061</b>	*) <b>IM 2071</b>	H = foot/flange-mounted, term.box top S = foot/flange-mounted, term.box RHS T = foot/flange-mounted, term.box LHS
	M000010						
Foot- and flange-mounted motor with feet, small flange	<b>IM B34</b> <b>IM 2101</b>	<b>IM V17</b> <b>IM 2111</b>	<b>IM 2131</b>	<b>IM 2151</b>	<b>IM 2161</b>	<b>IM 2171</b>	J = foot/flange-mounted, small flange
	M000011						
Foot-mounted motor, shaft with free extensions	<b>IM 1002</b>	<b>IM 1012</b>	<b>IM 1032</b>	<b>IM 1052</b>	<b>IM 1062</b>	<b>IM 1072</b>	
	M000012						
*) Not stated in IEC 60034-7.							

Note: In case of motors mounted with the shaft upwards and water or liquids are expected to go down along the shaft, the user must take care to mount some means capable of preventing it.

# Cooling

Designation system concerning methods of cooling refers to standard IEC 60034-6.

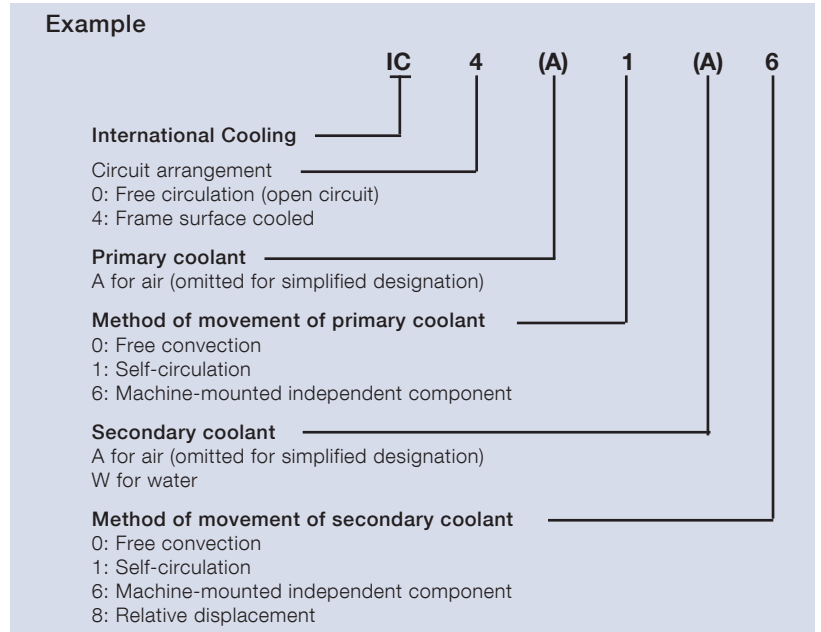

# Degrees of protection: IP code/IK code

Classification of degrees of protection provided by enclosures of rotating machines refers to:

- Standard IEC 60034-5 or EN 60529 for IP code
- Standard EN 50102 for IK code

### IP protection:

Protection of persons against getting in contact with (or approaching) live parts and against contact with moving parts inside the enclosure. Also protection of the machine against ingress of solid foreign objects. Protection of machines against the harmful effects due to the ingress of water.

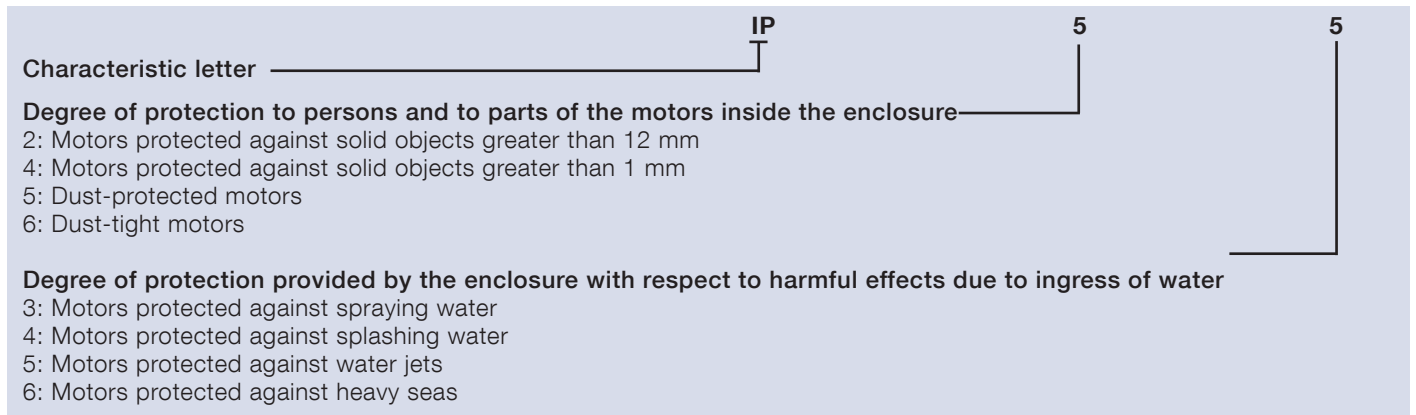

### IK code:

Classification of degrees of protection provided by enclosure for motors against external mechanical impacts.

**International mechanical protection**

**Characteristic group**

**Relation between IK code and impact energy:**

IK cod	IK 0	IK 01	IK 02	IK 03	IK 04	IK 05	IK 06	IK 07	IK 08	IK 09	IK 10
Impact energy Joule	*	0.15	0.2	0.35	0.5	0.7	1	2	5 ABB Standard	10	20

\* not protected according to EN 50102



# Insulation

ABB uses class F insulation systems, which, with temperature rise B, is the most common requirement among industry today.

The use of Class F insulation with Class B temperature rise gives ABB products a 25° C safety margin. This can be used to increase the loading by up to 12 percent for limited periods, to operate at higher ambient temperatures or altitudes, or with greater voltage and frequency tolerances. It can also be used to extend insulation life. For instance, a 10 K temperature reduction will extend the insulation life.

## Class F insulation system

- Max ambient temperature 40° C
- Max permissible temperature rise 105 K
- Hotspot temperature margin + 10 K

## Class B rise

- Max ambient temperature 40° C
- Max permissible temperature rise 80 K
- Hotspot temperature margin + 10 K

## Insulation system temperature class

- Class F 155° C
- Class B 130° C
- Class H 180° C

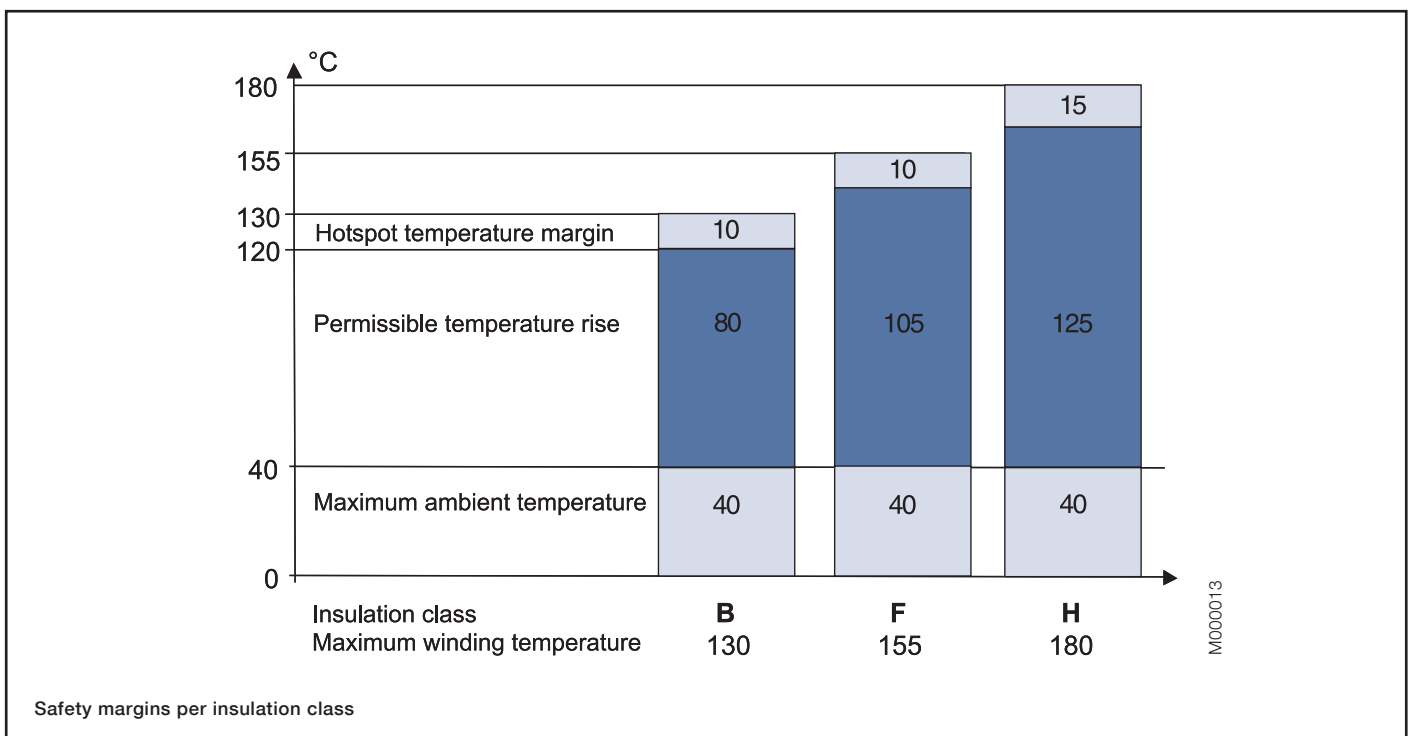

# Frequency converter drives for Industrial performance motors

Squirrel cage induction motors offer excellent availability, reliability and efficiency. With a frequency converter – a variable speed drive (VSD) – the motor will deliver even better value. Instead of running the motor at full speed all the time, the variable speed drive enables it to be run at a speed based on actual needs. This also makes it possible to control the process accurately and in some cases even to improve the capacity of the process by operating at speeds higher than the nominal.

In contrast to conventional direct on line (DOL) applications, VSDs make smooth starting possible. This significantly reduces the stress to the motor and the driven application caused by starting. Smooth starting also means that the supply network is not affected by high starting current transients, a factor which can be taken into account in the design of the network.

The utilization of ABB Industrial performance motors together with variable speed drives, and especially with ABB Standard Drives, usually provides substantial energy savings as the speed and thus the power required by the process can be optimized. Energy savings deliver not only environmental but also financial benefits, meaning that the combination of an ABB Industrial performance motor and a variable speed drive represents a cost effective solution for various applications.

ABB's Industrial performance range includes motors suitable for use with frequency converters, and especially with ABB Standard Drives. For more demanding applications the use of ABB Process performance motors and ABB Industrial Drives is recommended.

Correct dimensioning and utilization of appropriate variants ensures that ABB Industrial performance motors will provide the maximum benefit and best possible availability. The following points should therefore be taken into account when selecting the motor:

## 1. Dimensioning

The voltage (or current) fed by the frequency converter is not purely sinusoidal. This may increase motor losses, vibration and noise levels. Furthermore, the distribution of losses may be changed, which may also affect the motor's temperature rise. The motor and converter must therefore be evaluated as a combination to ensure that the dimensioning is correct.

When using ABB converters, please use ABB's DriveSize program for dimensioning purposes. This tool utilizes dimensioning rules based on comprehensive combined type tests.

For manual dimensioning, please note that the loadability (or load capacity) curves provided in this catalogue (Figure 2 and 3) and in the respective manuals are indicative only. Exact values for the specific motor and converter are available on request. In addition to thermal dimensioning, an adequate torque margin must be maintained for stability. The maximum torque of the motor must be at least 30 percent higher than the load torque over the whole duty range.

The voltage drop in the supply cables must be taken into consideration, especially in cases where long supply cables are used.

## 2. Operating speed, vibrations and shaft seals

Industrial performance motors are designed to operate over a wide speed range and in most cases also at significantly higher speeds than the nominal speed. The maximum speed can be found by using the DriveSize tool. In addition to the motor speed range, please ensure that the maximum or critical speed of the entire application is not exceeded.

If a particularly low level of vibration is required, motors with improved balancing should be used.

Guideline maximum speed values for Industrial performance motors are shown in Table 1 (motors with aluminum frames) and Table 2 (steel frames). Exact values are available on request.

**Table 1. Guideline maximum speed values for Industrial performance motors with aluminum frames**

Motor size	Speed r/min	
	2-pole	4-pole
63-80	6000	6000
90-100	6000	6000
112-200	4500	4500
225-280	3600	3600

**Table 2. Guideline maximum speed values for Industrial performance motors with steel frames**

Motor size	Speed r/min	
	2-pole	4-pole
280 SA, SMA, MB	3600	2600
280 MC, MD	3600	2300
315 SA, SMA, MB, LA	3600	2300
315 LB, LC	3600	2400
355 SA, SB, MA, MB, LA, LB	3600	2000
355 LKD	3600	1800
400	3600	1800

## 3. Ventilation

When the motor is operated at low speeds the cooling capacity of the fan decreases, reducing the motor's load capacity. A separate constant speed fan can be used to increase cooling capacity.

At high speeds, the use of metal fans instead of plastic ones should be considered. If a low noise level is required, the use of unidirectional or special low noise fans is recommended.

#### 4. Lubrication

In variable speed applications, the bearing temperature varies as a function of the speed and motor load. In such cases, the most accurate re-lubrication intervals can be obtained by measuring the bearing temperature under normal operating conditions. If the measured temperature is higher than +80°C, the re-lubrication intervals specified in the motor manual must be shortened or lubricants suitable for high operating temperatures must be used. See the ABB Low voltage motor manual.

In the case of continuous operation at very low speeds as well as at very low temperatures (below -20°C), the lubrication capabilities of standard greases may not be sufficient and special greases with additives are needed. For more information, please contact ABB.

When motors are equipped with sealed bearings, i.e. bearings greased for life, it must be noted that if the operating temperature differs from the design temperature, the bearing lifetime will also be different. More information on bearing lifetimes can be found in the product-specific sections of this catalogue and in the relevant manuals.

The use of so-called conductive greases for elimination of bearing currents is not recommended due to their poor lubrication characteristics and low conductivity.

#### 5. Winding insulation

A frequency converter supply causes greater voltage stresses in the motor windings than a sinusoidal supply. The insulation system and, in some cases, filters must be selected according to the voltage and converter type in question. See Table 3 for information on selecting the insulation system and filters.

In cases where the instructions shown in the table cannot be applied, and for other converters, selection must be based on the voltages present at the motor terminals.

The allowed phase-to-ground voltage peaks at the motor terminals are:

- ABB Standard Insulation 1300 V peak
- ABB Special Insulation (variant code 405) 1800 V peak

The maximum allowed phase-to-phase voltage peaks at the motor terminals, as a function of the pulse rise time, are shown in the Figure 1. The highest curve, "ABB Special Insulation", applies to motors with special winding insulation for frequency converter supply, variant code 405, see variant code for availability.

**Table 3. Selection of winding insulation and filters in case of ABB ACS800 or ACS550 drives with uncontrolled DC voltage.**

Nominal supply voltage $U_N$ of the converter	Winding insulation and filters required
$U_N \leq 500$ V	ABB Standard insulation
$U_N \leq 600$ V	ABB Standard insulation + dU/dt filters OR
	ABB Special insulation (variant code 405)
$U_N \leq 690$ V	ABB Special insulation (variant code 405) AND
	dU/dt-filters at converter output
$600 \text{ V} < U_N \leq 690 \text{ V}$ AND cable length > 150 m	ABB Special insulation (variant code 405)

For more information on dU/dt filters, please see the relevant ABB Drives catalogues.

**Figure 1. The maximum allowed phase-to-phase voltage peaks at the motors terminals, as a function of the pulse rise time**

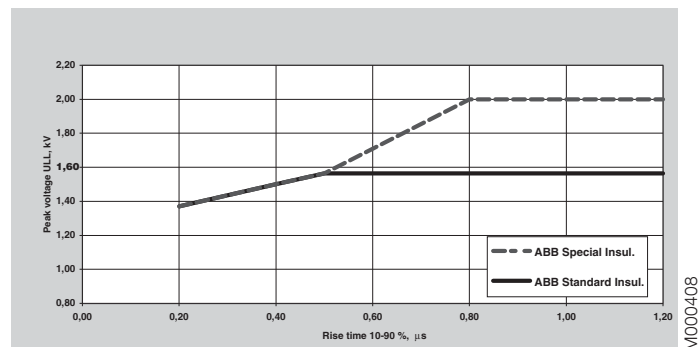

#### 6. Bearing currents

Bearing voltages and currents must be avoided in all motors to ensure reliable operation of the entire application. Assuming the use of ABB ACS800 or ACS550 drives, with uncontrolled DC voltage, insulated bearings (variant code 701) and/or properly dimensioned filters at the converter must be used according to Table 4. For other alternatives and converter types, please contact ABB. When ordering, clearly state which alternative will be used.

For more information about bearing currents and voltages, please see the "Bearing currents in AC drive systems" Fact File or contact ABB.

**Table 4. Prevention of bearing currents in motors used with ABB's ACS800 and ACS550 drives with uncontrolled DC voltage. For other alternatives and converter types, please contact ABB.**

Nominal Power ( $P_N$ ) and / or Frame size (IEC)	Preventive measures
$P_N < 100$ kW	No action needed
$P_N \geq 100$ kW OR IEC 315 $\leq$ Frame size $\leq$ IEC 355	Insulated non-drive end bearing
	OR
$P_N \geq 350$ kW OR IEC 400	Insulated non-drive end bearing
	AND Common mode filter at the converter

### Common mode filters

Common mode filters reduce common mode currents and thus decrease the risk of bearing currents. Common mode filters do not significantly affect the phase or main voltages on the motor terminals. For more information, please see ABB Drives catalogues.

### Insulated Bearings

ABB uses bearings with insulated inner or outer races.

### 7. Cabling, grounding and EMC

The use of a frequency converter sets higher demands on the cabling and grounding of the drive system. The motor must be cabled using shielded symmetrical cables and cable glands providing 360° bonding (also called EMC glands, variant code 704). For motors up to 30 kW asymmetrical cables can be used, but shielded cables are always

recommended, especially if there are sensitive components in the driven application.

For motors with frame size IEC 280 and upward, additional potential equalization is needed between the motor frame and the machinery, unless the motor and driven machine are installed on a common steel base. When a steel base is used for potential equalization, the high frequency conductivity of the connection must be checked. More information about grounding and cabling for variable speed drives can be found in the manual "Grounding and cabling of the drive system" (Code: 3AFY 61201998 R0125 REV B).

In order to meet EMC requirements, special EMC cable(s) must be used in addition to the correct cable gland mounting, with special, extra earthing pieces. Please refer to the frequency converter manuals.

**Figure 2. Loadability curves with ACS800 converters with DTC control**

**Note. Loadability curves for temperature rise F only applicable for motors having nominal temperature rise according to class B.**

**ACS800/50 Hz, Temperature rise B**

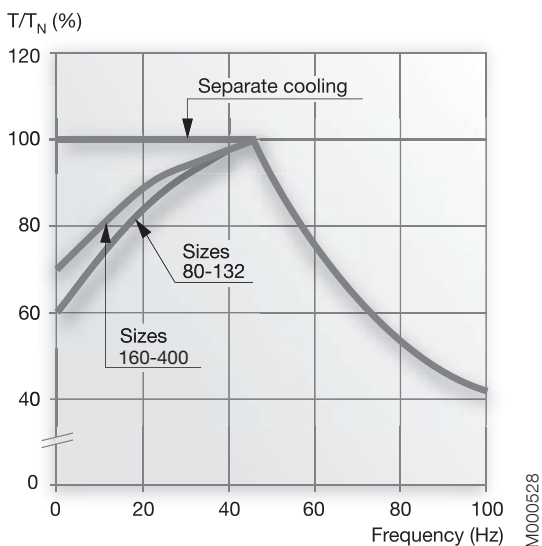

**ACS800/50 Hz, Temperature rise F**

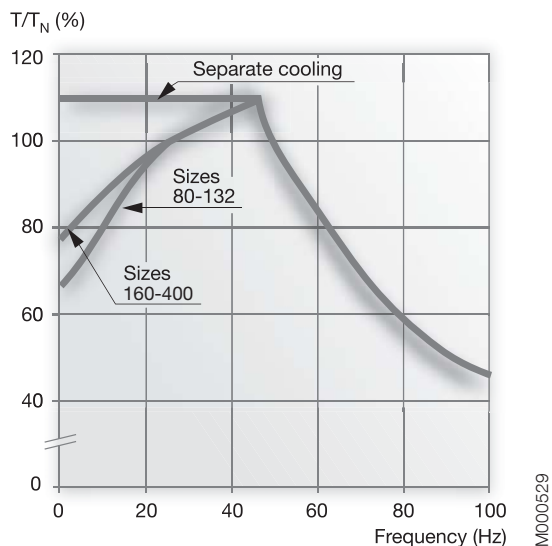

**Figure 3. Loadability curves with ACS550 converters**

**Note. Loadability curves for temperature rise F only applicable for motors having nominal temperature rise according to class B.**

**ACS550/50 Hz, Temperature rise B**

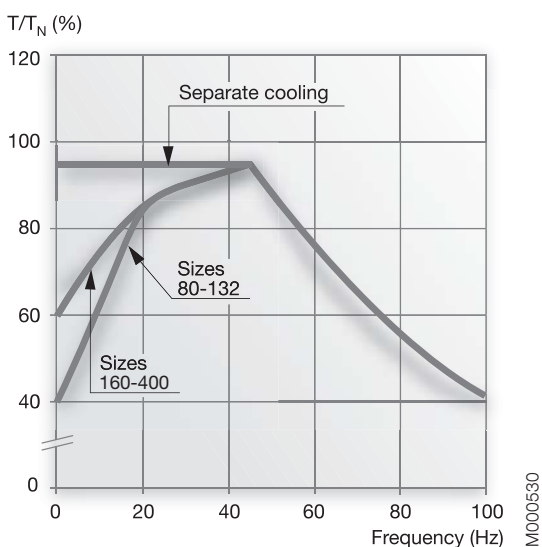

**ACS550/50 Hz, Temperature rise F**

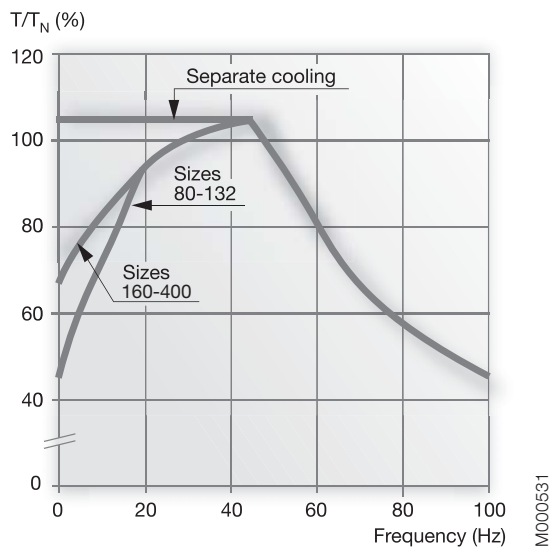

# Industrial performance aluminum motors

## Totally enclosed squirrel cage three phase low voltage motors

### Sizes 63 to 280, 0.12 to 90 kW



[www.abb.com/motors&generators](http://www.abb.com/motors&generators)

> Motors

>> Low voltage motors

>>> Industrial performance motors



# Mechanical design

## Stator

Stator framework is made aluminum alloy. Frame sizes 63 and 180 have aluminum feet and sizes 200 to 280 have cast iron feet.

The bearing shields of sizes 160 to 280 are made of cast iron.

## Drain holes

Motors that will be operated in very humid or wet environments and especially under intermittent duty should be provided with drain holes. The appropriate IM designation, such as IM 3031, is specified on the basis of the method of mounting the motor.

the upper plug must be hammered home completely. In very dusty environments both plugs should be hammered home.

Motors are supplied with drain holes both on D-end and N-end.

Motors are provided with closable plastic plugs in the drain holes (see diagram below). The plugs will be open on delivery. When mounting the motors it should be ensured that the drain holes face downwards. In the case of vertical mounting,

When mounting arrangement differs from foot mounted IM B3, please mention variant code 066 when ordering. See variant codes 065, 066 and 076 under the heading "Drain holes".

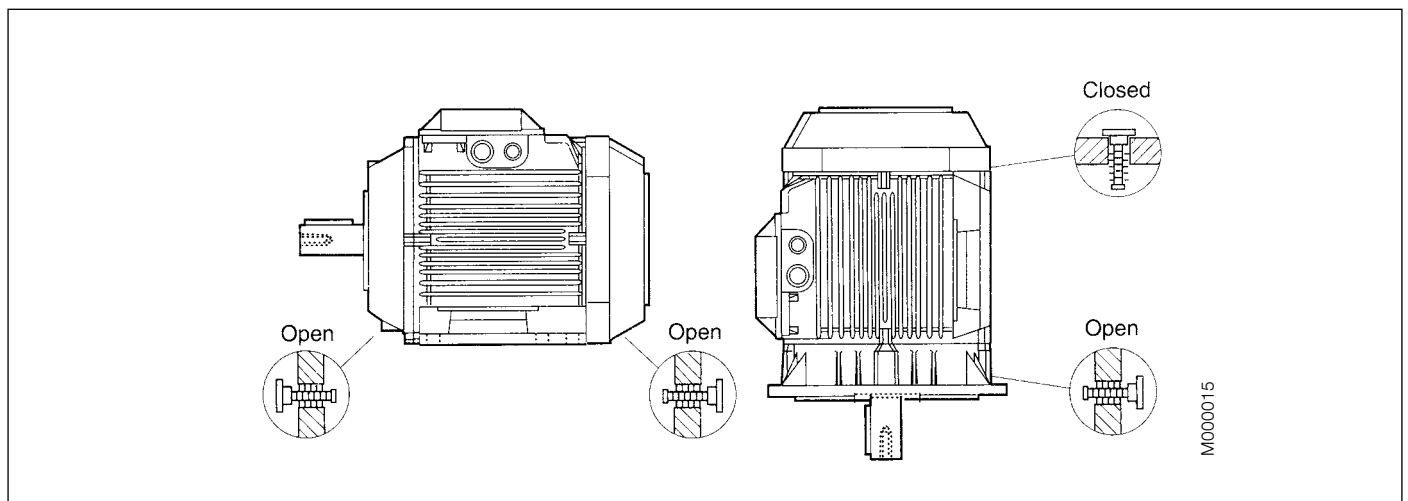

## Terminal box

### Sizes 63 to 180

The terminal box is made of aluminum alloy and is located on top of the stator. The lower part of the box is integrated with the stator. It is provided with two knockout openings on each side. Sizes 132 SM\_ and 160-180 also have a third smaller opening. Cable glands are not included.

are sealed by means of plastic plugs. Cable glands are not supplied. The opening on the other side is provided with a cover flange.

### Sizes 200 to 280

The terminal box and cover are made of deep drawn steel and mounted on top of the stator. The box is bolted to the stator and is not rotatable. The size of the box is the same for all motors.

The motors can also be provided with an extra large terminal box, standard for voltage code S and frame size 280. See variant code 019 under the heading "Terminal box". This will increase the dimension HD by 32 mm. The box is supplied with two FL 21 openings. The right opening is provided with a flange with two holes for M63 cable glands. The holes are sealed by means of plastic plugs. Cable glands are not supplied. The opening on the other side is provided with a cover flange. The box can also be provided with an FL 13 opening towards the N-end.

In the basic design the terminal box is provided with two FL 13 flange openings, one on each side. The opening on the right side, seen from the D-end, is supplied with a flange with two holes for M40 cable glands. On delivery the holes

When new motors are manufactured the terminal box can be mounted on the left or the right side. See variant codes 021 and 180 under the heading "Terminal box".

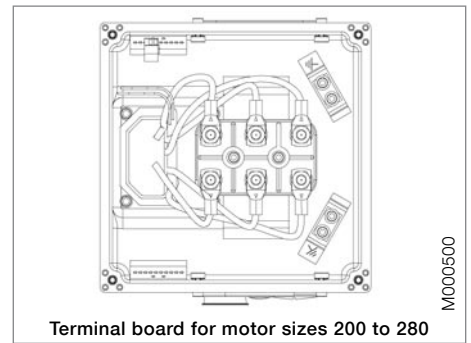
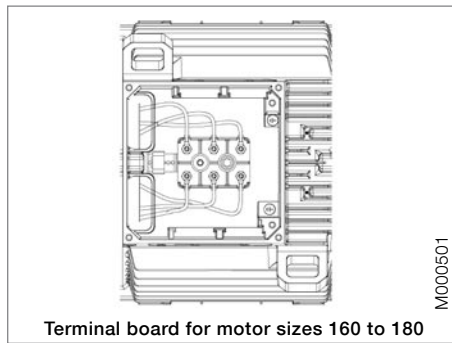
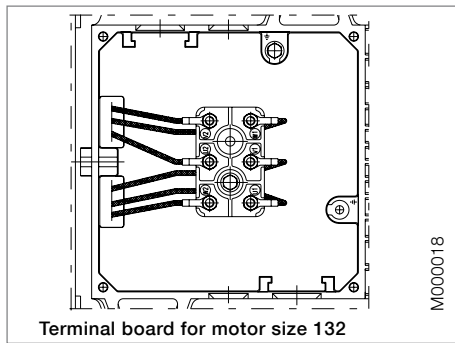
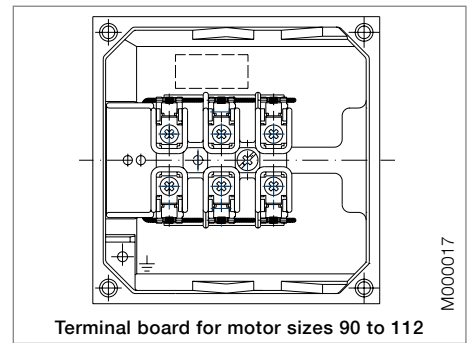
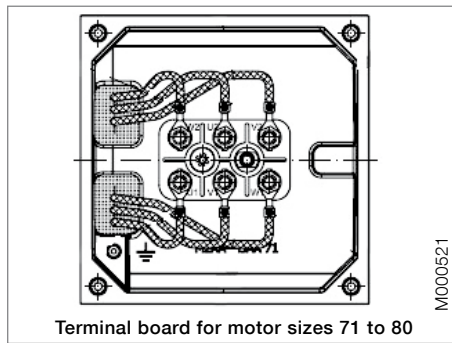
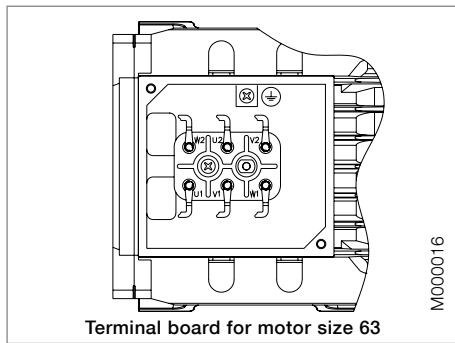

## Connections

The terminal block is provided with six terminals for connecting Cu-cable. The terminals are marked in accordance with IEC 60034-8.

### Connection openings

Motor size	Opening	Metric cable entry	Method of connection	Terminal bolt size	Maximum connectable Cu-cable area, mm <sup>2</sup>
63	Knock-out opening	1 x M16 x 1.5 1 x Pg 11	Cable lug	M4	2.5
71-80	Knock-out opening	2 x ( 2 x M20 )	Cable lug	M4	4
90-112	Knock-out opening	2 x (M25 + M20)	Screw terminal	M4	6
132 <sup>1)</sup>	Knock-out opening	2 x (M25 + M20)	Cable lug	M5	10
132 <sup>2)</sup>	Knock-out opening	2 x (M40 x M32 + M12)	Cable lug	M6	35
160-180	Knock-out opening	2 x (2 x M40 + M16)	Cable lug	M6	35
200-250	2 x FL 13	1 x (2 x M40 + M16)	Cable lug	M10	70
280	2 x FL 21	1 x (2 x M63 + M16)	Cable lug	M10	70

<sup>1)</sup> all types except <sup>2)</sup>  
<sup>2)</sup> SM\_

## Dimensions for terminal box

**Code 019** Larger than standard terminal box

Motor size	Dimensions	Dimensions			
		AD	HB	HD	HE
M3AA	200 ML.	332.5	332.5	603	240
M3AA	225 SM.	353	353	578	260.5
M3AA	250 SM.	376	376	626	283.5

**Code 021** Terminal box on left-hand side seen from D end

**Code 180** Terminal box on right-hand side seen from D end

Motor size	Dimensions	Dimensions			
		AD	HB	HD	HE
M3AA	200 ML.	332	332	532	239
M3AA	225 SM.	354	354	579	260.5
M3AA	250 SM.	377	377	627	284

**Code 467** Lower than standard terminal box without screw terminals and extended rubber connection cable 2 m.

Motor size	Dimensions		
	AD	HB	HD
160		211.5	371.5
180		226.5	406.5
200 ML.	248	248	448
225 SM.	269	269	494
250 SM.	292	292	542
280	292	292	572

# Bearings

The motors are provided with bearings according to the tables below.

Greater axial forces can be tolerated if the motors are provided with angular contact ball bearings.

## Basic version with deep groove ball bearings

Basic design motors			
Motor size	Foot- and flange-mounted motor		
	D-end	N-end	
63	6202-2Z/C3	6201-2Z/C3	
71	6203-2Z/C3	6202-2Z/C3	
80	6204-2Z/C3	6203-2Z/C3	
90	6205-2Z/C3	6204-2Z/C3	
100	6306-2Z/C3	6205-2Z/C3	
112	6306-2Z/C3	6205-2Z/C3	
132 <sup>1)</sup>	6208-2Z/C3	6206-2Z/C3	
132 <sup>2)</sup>	6308-2Z/C3	6206-2Z/C3	
160	6309-2Z/C3	6209-2Z/C3	
180	6310-2Z/C3	6209-2Z/C3	
200	6312-2Z/C3	6210-2Z/C3	
225	6313-2Z/C3	6212-2Z/C3	
250	6315-2Z/C3	6213-2Z/C3	
280	2-pole 6315/C3	6213/C3	
280	4-8 pole 6316/C3	6213/C3	

<sup>1)</sup> all types except <sup>2)</sup>

<sup>2)</sup> SM\_

Note that in such cases the axial force must only operate in one direction.

Motor versions with roller bearings tolerate greater radial forces.

## Alternative designs:

### Version with roller bearings

It is recommended to use roller bearings in belt drives for motor sizes 160 to 280.

See variant code 037 under the heading "Bearings and lubrication".

Motor size	D-end	N-end
90	NU 205	–
100	NU 306	–
112	NU 306	–
132 <sup>1)</sup>	NU 208	–
132 <sup>2)</sup>	NU 308	–
160	NU 309 ECP	–
180	NU 310 ECP	–
200	NU 312 ECP	–
225	NU 313 ECP	–
250	NU 315 ECP	–
280	2-pole NU 315 ECP	–
280	4-8 pole NU 316 ECP	–

<sup>1)</sup> all types except <sup>2)</sup>

<sup>2)</sup> SM\_

### Version with angular contact ball bearings

See variant codes 058 and 059 under the heading "Bearings and lubrication".

Motor size	D-end 058	N-end 059
90	7205 B	7204 B
100	7306 B	7205 B
112	7306 B	7205 B
132 <sup>1)</sup>	7208 B	7206 B
132 <sup>2)</sup>	7308 B	7206 B
160	7309 BEP	7209 BEP
180	7310 BEP	7209 BEP
200	7312 BEP	7210 BEP
225	7313 BEP	7212 BEP
250	7315 BEP	7213 BEP
280	2-pole 7315 BEP	7213 BEP
280	4-8 pole 7316 BEP	7213 BEP

<sup>1)</sup> all types except <sup>2)</sup>

<sup>2)</sup> SM\_



## Transport locking

Motors provided with roller bearings or angular contact ball bearings are fitted with a transport lock to prevent damage to the bearings, due to vibration, during transport.

## Axially-locked bearings

The table below shows which of the motor's bearings are axially locked in the bearing seat. In motor sizes 63 to 80 the locking is done by an internal retaining ring, in motor sizes 90 to 280 by an inner bearing cover.

See also variant code 042 under the heading "Bearings and lubrication".

Motor size	Foot-mounted motors	Flange-mounted motors	
		Large flange	Small flange
63	On request at D-end	On request at D-end	On request at D-end
71-132	D-end <sup>1)</sup>	D-end <sup>1)</sup>	D-end <sup>1)</sup>
160-280	D-end	D-end	–

<sup>1)</sup> A spring-washer at the N-end presses the rotor toward the D-end.

## Lubrication

The motors are delivered with bearing grease for use at normal temperatures in dry or humid environments. The motors are lubricated for ambient temperatures 40°C and in some cases even above 40°C, see table 1 next page.

Motor sizes 63 to 250 are provided with shielded bearings. As an option, motor sizes 90 to 250 are provided with grease nipples for regreasing, see variant code 041 under the heading "Bearings and lubrications".

Motor size 280 is provided with grease nipples for re-greasing as standard.

The lubrication interval  $L_1$ , suitable for relubricated bearings, is defined as the number of operating hours after which 99 percent of the bearings are adequately lubricated.

Lubrication intervals and grease quantities are specified on a plate on the motor as well as in the manual supplied with the motor.

The grease lifetime  $L_{10}$ , suitable for permanent lubricated bearings, is defined as the number of operating hours after which 90 percent of the bearings are adequately lubricated. 50 percent of the bearings achieve two times this figure. Maximum lifetime, however, should be regarded as 40,000 hours.

In case of high ambient temperatures the shaft loads must be reduced compared to permissible loadings in the table (see pages 18 to 19), please contact ABB.

**Table 1: Grease lifetime  $L_{10}$  in deep groove ball bearings of type 2Z in horizontally mounted motors in continuous running duty.**

Motor	r/min	Ambient temperature and rated output												
		25 °C		40 °C		50 °C		60 °C		70 °C		80 °C		
		Basic	High	Basic	High	Basic	High	Basic	High	Basic	High	Basic	High	
63	3000	40000	40000	40000	40000	40000	40000	31000	31000	17000	17000	9000	9000	
	1500	40000	40000	40000	40000	40000	40000	33000	33000	18000	18000	9000	9000	
	1000	40000	40000	40000	40000	40000	40000	33000	33000	18000	18000	9000	9000	
	750	40000	40000	40000	40000	40000	40000	33000	33000	18000	18000	9000	9000	
71	3000	40000	40000	40000	40000	40000	40000	27000	27000	15000	15000	8000	8000	
	1500	40000	40000	40000	40000	40000	40000	33000	33000	18000	18000	9000	9000	
	1000	40000	40000	40000	40000	40000	40000	33000	33000	18000	18000	9000	9000	
	750	40000	40000	40000	40000	40000	40000	33000	33000	18000	18000	9000	9000	
80	3000	40000	40000	40000	40000	39000	39000	23000	23000	13000	13000	7000	7000	
	1500	40000	40000	40000	40000	40000	40000	33000	33000	18000	18000	9000	9000	
	1000	40000	40000	40000	40000	40000	40000	33000	33000	18000	18000	9000	9000	
	750	40000	40000	40000	40000	40000	40000	33000	33000	18000	18000	9000	9000	
90	3000	40000	40000	40000	40000	33000	33000	20000	20000	11000	11000	6000	6000	
	1500	40000	40000	40000	40000	40000	40000	33000	33000	18000	18000	9000	9000	
	1000	40000	40000	40000	40000	40000	40000	33000	33000	18000	18000	9000	9000	
	750	40000	40000	40000	40000	40000	40000	33000	33000	18000	18000	9000	9000	
100	3000	40000	40000	39000	39000	25000	25000	15000	15000	8000	8000	4000	4000	
	1500	40000	40000	40000	40000	40000	40000	30000	30000	17000	17000	9000	9000	
	1000	40000	40000	40000	40000	40000	40000	33000	33000	18000	18000	9000	9000	
	750	40000	40000	40000	40000	40000	40000	33000	33000	18000	18000	9000	9000	
112	3000	40000	40000	39000	39000	25000	25000	15000	15000	8000	8000	4000	4000	
	1500	40000	40000	40000	40000	40000	40000	30000	30000	17000	17000	9000	9000	
	1000	40000	40000	40000	40000	40000	40000	33000	33000	18000	18000	9000	9000	
	750	40000	40000	40000	40000	40000	40000	33000	33000	18000	18000	9000	9000	
132 <sup>1)</sup>	3000	40000	40000	33000	33000	21000	21000	13000	13000	7000	7000	4000	4000	
	1500	40000	40000	40000	40000	40000	40000	26000	26000	14000	14000	7000	7000	
	1000	40000	40000	40000	40000	40000	40000	33000	33000	18000	18000	9000	9000	
	750	40000	40000	40000	40000	40000	40000	33000	33000	18000	18000	9000	9000	
132 <sup>2)</sup>	3000	40000	40000	31000	31000	20000	20000	12000	12000	6000	6000	3000	3000	
	1500	40000	40000	40000	40000	40000	40000	24000	24000	13000	13000	7000	7000	
	1000	40000	40000	40000	40000	40000	40000	33000	33000	18000	18000	9000	9000	
	750	40000	40000	40000	40000	40000	40000	33000	33000	18000	18000	9000	9000	
160	3000	40000	40000	40000	36000	40000	19000	26000	9000	14000	5000	8000	2000	
	1500	40000	40000	40000	40000	40000	40000	40000	38000	40000	20000	37000	10000	
	1000	40000	40000	40000	40000	40000	40000	40000	40000	40000	24000	40000	12000	
	750	40000		40000		40000		40000		40000		40000		
180	3000	38000	38000	38000	38000	38000	38000	38000	23000	23000	12000	13000	7000	
	1500	40000	40000	40000	40000	40000	40000	24000	40000	12000	26000	6000	13000	3000
	1000	40000	40000	40000	40000	40000	40000	40000	40000	40000	24000	29000	12000	
	750	40000		40000		40000		40000		40000		37000		21000
200	3000	27000	27000	27000	27000	27000	18000	24000	10000	14000	5000	8000	3000	
	1500	40000	40000	40000	40000	40000	40000	40000	32000	40000	18000	30000	10000	
	1000	40000	40000	40000	40000	40000	40000	40000	40000	40000	30000	38000	17000	
	750	40000		40000		40000		40000		40000		40000		40000
225	3000	23000	23000	23000	18000	23000	10000	20000	6000	12000	3000	7000	1000	
	1500	40000	40000	40000	40000	40000	23000	40000	12000	40000	6000	25000	3000	
	1000	40000	40000	40000	40000	40000	40000	40000	40000	40000	40000	40000	27000	
	750	40000		40000		40000		40000		40000		40000		40000
250	3000	16000	16000	16000	13000	16000	7000	12000	4000	7000	2000	4000	1000	
	1500	40000	40000	40000	39000	40000	21000	40000	11000	33000	6000	19000	3000	
	1000	40000	40000	40000	40000	40000	40000	40000	40000	40000	25000	36000	13000	
	750	40000		40000		40000		40000		40000		40000		40000

<sup>1)</sup> all types except <sup>2)</sup>

<sup>2)</sup> SM<sub>L</sub>

In vertically mounted motors, the grease lifetime is half the figures above.

For applications corresponding to the empty cells in the table, please contact ABB. These applications can imply reduced lifetime for bearings and winding. Motors with roller bearings (optional) have considerably shorter grease life. For continuous operation regreasing nipples should be considered.

# Lubrication intervals

ABB follows the  $L_1$ -principle in defining lubrication interval. That means that 99 percent of the motors are sure to make the interval time. The lubrication intervals can also be calculated according to the  $L_{10}$ -principle, which are normally doubled compared to  $L_1$ -values. Values available from ABB at request.

The table below gives lubrication intervals according to the  $L_1$ -principle for different speeds. The values are valid for horizontal mounted motors (B3), with about 80°C bearing temperature and using good quality grease with lithium complex soap and with mineral or PAO-oil.

For more information, see ABB's Low Voltage Motors Manual.

Frame size	Amount of grease g	3600 r/min	3000 r/min	1800 r/min	1500 r/min	1000 r/min	500-750 r/min
<b>Ball bearings:</b>		lubrication intervals in duty hours					
280	60	2000	3500	-	-	-	-
280	70	-	-	8000	10500	14000	17000

Frame size	Amount of grease g	3600 r/min	3000 r/min	1800 r/min	1500 r/min	1000 r/min	500-750 r/min
<b>Roller bearings:</b>		lubrication intervals in duty hours					
280	60	1000	1750	-	-	-	-
280	70	-	-	4000	5250	7000	8500

## Pulley diameter

When the desired bearing life has been determined the minimum permissible pulley diameter can be calculated with  $F_R$ , according to the formula:

$$D = \frac{1.9 \cdot 10^7 \cdot K \cdot P}{n \cdot F_R}$$

where:

$D$  = diameter of pulley, mm

$P$  = power requirement, kW

$n$  = motor speed, r/min.

$K$  = belt tension factor, dependent on belt type and type of duty. A common value for V-belts is  $K = 2.5$

$F_R$  = permissible radial force according to the tables

## Bearing life

The nominal life is defined as the number of hours that are attained or exceeded by 90 percent of identical bearings, in a large test series, under certain specified conditions. 50 percent of the bearings attain a life of as much as 5 times this figure.

The life of bearings is dependent on various factors such as bearing load, motor speed, operating temperature and the purity of the grease. The permissible radial and axial loading for different motor sizes is shown in the table on the following pages.

The table is valid for 50 Hz. For 60 Hz and/or some other bearing life than specified in the table the values are changed according to the table on the right.

The table values assume the occurrence of only radial or axial forces. In the case of simultaneous radial and axial forces information can be supplied on request. It is assumed that the radial force is applied at the end of the motor shaft.

### Permissible force at changed bearing life or supply frequency

Bearing life in hours at		Permissible force, as percentage of value in tables
50 Hz	60 Hz	
25,000	21,000	100 % of value for 25,000 hours
40,000	33,000	100 % of value for 40,000 hours
63,000	52,000	86 % of value for 40,000 hours
80,000	67,000	80 % of value for 40,000 hours

## Permissible loading on shaft

The tables give the permissible radial force in Newtons, assuming zero axial force, ambient temperature of 25°C.

Permissible loads of simultaneous radial and axial forces will be supplied on request.

The bearing life,  $L_{10}$ , is calculated according to SKF's theory on bearing life  $L_{10\text{aah}}$ , which also takes the purity of the grease into consideration. An adequate lubrication is a necessary prerequisite for the table at right.

If the radial force is applied between points  $X_0$  and  $X_{\text{max}}$ , the permissible force  $F_R$  can be calculated from the following formula:

$$F_R = F_{X_0} - \frac{X}{E} (F_{X_0} - F_{X_{\text{max}}})$$

$E$  = length of shaft extension in basic version.

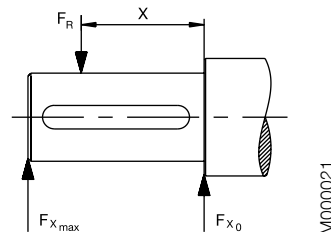

M000021

## Permissible radial forces

### Motor sizes 63 to 132

Motor size	No. of poles	Length of shaft extension E (mm)	Ball bearings Basic design with deep groove ball bearings			
			25,000 hrs		40,000 hrs	
			FX <sub>0</sub> (N)	FX <sub>max</sub> (N)	FX <sub>0</sub> (N)	FX <sub>max</sub> (N)
63	2	23	490	400	490	400
	4	23	490	400	490	400
	8	23	490	400	490	400
71	2	30	680	570	680	570
	4	30	680	570	680	570
	6	30	680	570	680	570
80	2	40	630	750	930	750
	4	40	930	750	930	750
	6	40	930	750	930	750
90	2	50	1010	810	1010	810
	4	50	1010	810	1010	810
	6	50	1010	810	1010	810
100	2	60	2280	1800	2280	1800
	4	60	2280	1800	2280	1800
	6	60	2280	1800	2280	1800
	8	60	2280	1800	2280	1800

Motor size	No. of poles	Length of shaft extension E (mm)	Ball bearings Basic design with deep groove ball bearings				
			25,000 hrs		40,000 hrs		
			FX <sub>0</sub> (N)	FX <sub>max</sub> (N)	FX <sub>0</sub> (N)	FX <sub>max</sub> (N)	
112	2	60	2280	1800	2280	1800	
	4	60	2280	1800	2280	1800	
	6	60	2280	1800	2280	1800	
	8	60	2280	1800	2280	1800	
	132 <sup>1)</sup>	2	80	2120	1610	2120	1610
		4	80	2120	1610	2120	1610
6		80	2120	1610	2120	1610	
	8	80	2120	1610	2120	1610	
	132 <sup>2)</sup>	2	80	2600	2100	2600	2100
		4	80	2600	2100	2600	2100
6		80	2600	2100	2600	2100	
	8	80	2600	2100	2600	2100	

<sup>1)</sup> 62-series bearings

<sup>2)</sup> 63-series bearings

### Motor sizes 160 to 280

Motor size	No. of poles	Length of shaft extension E (mm)	Ball bearings Basic design with deep groove ball bearings				Roller bearings Alternative design with roller bearings			
			20,000 hrs		40,000 hrs		20,000 hrs		40,000 hrs	
			FX <sub>0</sub> (N)	FX <sub>max</sub> (N)	FX <sub>0</sub> (N)	FX <sub>max</sub> (N)	FX <sub>0</sub> (N)	FX <sub>max</sub> (N)	FX <sub>0</sub> (N)	FX <sub>max</sub> (N)
160	2	110	4760	3860	4100	3320	6580	4300	5620	4300
	4	110	5180	4200	4380	3545	7340	4300	6180	4300
	6	110	5160	4180	4360	3540	7780	4300	6500	4300
	8	110	6280	4300	5320	4300	8860	4300	7440	4300
180	2	110	6060	4960	5280 <sup>1)</sup>	4305 <sup>1)</sup>	7600	5500	6560	5500
	4	110	4800	3940	4020	3300	7280	5500	6140	5500
	6	110	6280	5140	5280	4380	8680	5500	7280	5500
	8	110	6960	5500	5880	4800	9440	5500	7920	5500
200	2	110	7800	6500	6760 <sup>2)</sup>	5640 <sup>2)</sup>	10360	8640	8880	7400
	4	110	8400	7020	7180	5980	11560	9550	9800	8180
	6	110	8960	7480	7600	6340	12480	9550	10520	8780
	8	110	10480	8740	8940	7400	14100	9550	11920	9550
225	2	110	8520	7180	7360 <sup>3)</sup>	6200 <sup>3)</sup>	12320	10380	10560	8900
	4	140	8380	6780	7200	5820	13380	10250	11320	9160
	6	140	10960	8860	9360	7560	15860	10250	13420	10250
	8	140	12100	9780	10340	8360	17220	10250	14580	10250
250	2	140	10480 <sup>4)</sup>	8500 <sup>4)</sup>	9080 <sup>4)</sup>	7360 <sup>4)</sup>	16220	10900	13960	10900
	4	140	10840	8780	9380	7600	18020	13800	15320	13800
	6	140	12600	10220	10700	8680	20240	13800	17140	13800
	8	140	14660	11880	12540	10160	22680	13800	19220	13800
280	2	140	6780	5500	5680	4600	16280	13200	14000	11360
	4	140	8060	6540	6640	5380	19480	15780	16540	13400
	6	140	8980	7280	7360	5960	21920	17760	18580	15060
	8	140	9180	7460	7460	6060	22240	18020	18860	15300

<sup>1)</sup> The maximum lifetime of the grease is 38 000 h, see page 18.

<sup>2)</sup> The maximum lifetime of the grease is 27 000 h, see page 18.

<sup>3)</sup> The maximum lifetime of the grease is 23 000 h, see page 18.

<sup>4)</sup> The maximum lifetime of the grease is 16 000 h, see page 18.

## Permissible axial forces

The following tables give the permissible axial forces in Newtons, assuming zero radial force, ambient temperature of 25°C. The values are based on normal conditions at 50 Hz with standard bearings and calculated bearing lives of 20,000 and 40,000 hours.

For two-speed motors, the values are to be based on the higher speed. The permissible loads of simultaneous radial and axial forces will be supplied on request.

Given axial forces  $F_{AD}$ , assumes D-bearing locked by means of locking ring.

At 60 Hz the values are to be reduced by 10 percent.

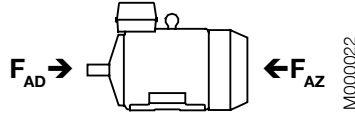

### Mounting arrangement IM B3

Motor size	20,000 hours								40,000 hours							
	2-pole		4-pole		6-pole		8-pole		2-pole		4-pole		6-pole		8-pole	
	$F_{AD}$ N	$F_{AZ}$ N	$F_{AD}$ N	$F_{AZ}$ N	$F_{AD}$ N	$F_{AZ}$ N	$F_{AD}$ N	$F_{AZ}$ N	$F_{AD}$ N	$F_{AZ}$ N	$F_{AD}$ N	$F_{AZ}$ N	$F_{AD}$ N	$F_{AZ}$ N	$F_{AD}$ N	$F_{AZ}$ N
63	480	125	565	165	580	190	590	195	420	105	470	115	490	145	590	205
71	625	325	780	480	890	590	985	685	515	215	630	330	710	410	780	480
80	810	470	1015	675	1170	830	1300	960	650	315	810	470	925	595	1015	675
90	885	485	1170	650	1270	870	1410	1010	720	320	945	425	1005	605	1110	710
100	1620	1120	2065	1565	2390	1890	2660	2160	1280	780	1615	1115	1860	1360	2065	1565
112 M	-	-	-	-	-	-	2655	2155	-	-	-	-	-	-	2060	1560
112 MB	1615	1115	2060	1560	2385	1885	2655	2155	1275	775	1610	1110	1860	1360	2060	1560
132 M	-	-	2245	1645	-	-	2875	2270	-	-	1760	1160	-	-	2240	1640
132 MA	-	-	2245	1645	2595	1995	-	-	-	-	1760	1160	2025	1425	-	-
132 MC	-	-	-	-	2580	1980	-	-	-	-	-	-	2010	1410	-	-
132 MBA	-	-	2235	1635	-	-	-	-	-	-	1750	1150	-	-	-	-
132 S	-	-	-	-	2600	2000	2885	2285	-	-	-	-	2030	1435	2245	1645
132 SA	-	-	-	-	-	-	-	-	-	-	-	-	-	-	-	-
132 SB	1770	1170	-	-	-	-	-	-	1400	800	-	-	-	-	-	-
132 SBB	1760	1160	-	-	-	-	-	-	1395	795	-	-	-	-	-	-
132 SC	1760	1160	-	-	-	-	-	-	1395	795	-	-	-	-	-	-
132 SMA	-	-	-	-	-	-	-	-	-	-	-	-	-	-	-	-
132 SMB	2220	1620	2840	2240	-	-	-	-	1740	1140	2205	1605	-	-	-	-
132 SMC	2220	1620	-	-	-	-	-	-	1740	1140	-	-	-	-	-	-
132 SMD	-	-	2830	2200	-	-	-	-	-	-	2230	1595	-	-	-	-
132 SME	2210	1610	-	-	-	-	-	-	1730	1130	-	-	-	-	-	-
160	4160	4160	4740	4740	4840	4840	5980	5980	4220	4220	-	-	-	-	4640	4640
180	5480	5480	4360	4360	5980	5980	6000	6620	4220 <sup>1)</sup>	4220 <sup>1)</sup>	4640	4640	4630	4630	4630	4630
200	5000	6880	5000	7660	5000	8300	5000	9880	4650 <sup>2)</sup>	4650 <sup>2)</sup>	4630	4630	4470	4470	4740	4740
225	5000	7380	5000	7600	5000	10140	5000	11420	4650 <sup>3)</sup>	4650 <sup>3)</sup>	4470	4470	4740	4740	4740	4740
250	6000 <sup>4)</sup>	9020 <sup>4)</sup>	6000	9800	6000	11520	6000	13700	4250 <sup>4)</sup>	4250 <sup>4)</sup>	4500	4500	-	-	-	-
280	5260	5260	6500	6500	7500	7500	7740	7740	-	-	4390	4390	4710	4710	4850	4850

<sup>1)</sup> The maximum lifetime of the grease is 38 000 h, see page 18.

<sup>2)</sup> The maximum lifetime of the grease is 27 000 h, see page 18.

<sup>3)</sup> The maximum lifetime of the grease is 23 000 h, see page 18.

<sup>4)</sup> The maximum lifetime of the grease is 16 000 h, see page 18.

## Permissible axial forces

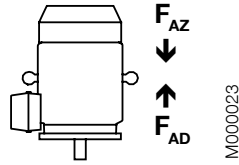

### Mounting arrangement IM V1

Motor size	20,000 hours								40,000 hours							
	2-pole		4-pole		6-pole		8-pole		2-pole		4-pole		6-pole		8-pole	
	F <sub>AD</sub> N	F <sub>AZ</sub> N	F <sub>AD</sub> N	F <sub>AZ</sub> N	F <sub>AD</sub> N	F <sub>AZ</sub> N	F <sub>AD</sub> N	F <sub>AZ</sub> N	F <sub>AD</sub> N	F <sub>AZ</sub> N	F <sub>AD</sub> N	F <sub>AZ</sub> N	F <sub>AD</sub> N	F <sub>AZ</sub> N	F <sub>AD</sub> N	F <sub>AZ</sub> N
63	495	115	585	155	600	180	-	-	440	95	490	105	550	115	-	-
71	640	315	800	470	925	570	1020	665	530	200	650	320	745	390	815	455
80	845	450	1075	640	1225	795	1350	925	690	290	865	430	980	550	1070	645
90	945	450	1245	600	1360	815	1485	960	775	280	1020	375	1095	550	1185	660
100	1710	1060	2180	1485	2510	1815	2780	2080	1370	715	1735	1035	1980	1285	2185	1485
112 M	-	-	-	-	-	-	2790	2070	-	-	-	-	-	-	2195	1475
112 MB	1725	1040	2210	1460	2540	1785	2810	2055	1385	700	1110	1010	2010	1260	2210	1460
132 M	-	-	2460	1505	-	-	3130	2115	-	-	1970	1015	-	-	2490	1470
132 MA	-	-	2460	1505	2815	1850	-	-	-	-	1970	1015	2245	1280	-	-
132 MC	-	-	-	-	2885	1780	-	-	-	-	-	-	2315	1210	-	-
132 MBA	-	-	2495	1465	-	-	-	-	-	-	2010	980	-	-	-	-
132 S	-	-	-	-	2780	1885	3100	2145	-	-	-	-	2210	1315	2460	1505
132 SA	-	-	-	-	-	-	-	-	-	-	-	-	-	-	-	-
132 SB	1910	1075	-	-	-	-	-	-	1540	705	-	-	-	-	-	-
132 SBB	1950	1050	-	-	-	-	-	-	1580	670	-	-	-	-	-	-
132 SC	1945	1045	-	-	-	-	-	-	1575	670	-	-	-	-	-	-
132 SMA	-	-	-	-	-	-	-	-	-	-	-	-	-	-	-	-
132 SMB	2435	1480	3150	2035	-	-	-	-	1950	995	2515	1400	-	-	-	-
132 SMC	2445	1470	-	-	-	-	-	-	1960	985	-	-	-	-	-	-
132 SMD	-	-	3195	1995	-	-	-	-	-	-	2560	1355	-	-	-	-
132 SME	2490	1425	-	-	-	-	-	-	2005	940	-	-	-	-	-	-
160	4560	3810	5260	4310	5400	4420	6560	5580	3860	3110	4440	3490	4540	3560	5460	4480
180	5920	5115	5080	3860	6000	5445	6000	6120	5060 <sup>1)</sup>	4255 <sup>1)</sup>	4240	3020	5600	4385	6000	4900
200	5000	6350	5000	6950	5000	7505	5000	9215	5000 <sup>2)</sup>	5230 <sup>2)</sup>	5000	5650	5000	6025	5000	7435
225	5000	6770	5000	6795	5000	9270	5000	10595	5000 <sup>3)</sup>	5490 <sup>3)</sup>	5000	5475	5000	7490	5000	8535
250	6000 <sup>4)</sup>	8335 <sup>4)</sup>	6000	8820	6000	10275	6000	12645	6000 <sup>4)</sup>	6755 <sup>4)</sup>	6000	7120	6000	8235	6000	10205
280	6400	4400	7920	5400	8500	6180	8500	6435	5420	3420	6640	4120	7840	4640	7980	4775

<sup>1)</sup> The maximum lifetime of the grease is 38 000 h, see page 18.

<sup>2)</sup> The maximum lifetime of the grease is 27 000 h, see page 18.

<sup>3)</sup> The maximum lifetime of the grease is 23 000 h, see page 18.

<sup>4)</sup> The maximum lifetime of the grease is 16 000 h, see page 18.

# Rating plates

The rating plate is in table form giving values for speed, current and power factor for three voltages.

The following information must be shown on the motor rating plate according to IEC 60034-30; 2008 and European MEPS (Commission Regulation, EC, No 640/2009):

- Lowest nominal efficiency at 100, 75 and 50 percent rated load
- Efficiency level (IE2 or IE3)
- Year of manufacture

## Motor sizes 71 to 80

<b>ABB</b> 3~Motor M3AA 080 C 2						IE2 CE	
3GAA081313-ASE			No. E101508P9150		Cl. F IP 55		
6204-2Z/C3		6203-2Z/C3				11 kg	
V	Hz	r/min	kW	A	Cos φ		
230 D / 400 Y	50	2880	1,1	4,1 / 2,4	0,78		
415 Y	50	2870	1,1	2,4	0,76		
IE2-81,9(100%)-81(75%)-78,5(50%)						2009 IEC 60034-1	

M000526

## Motor sizes 90 to 132

<b>ABB</b> 3~Motor M3AA 100 LB 2						IE2 CE	
3GAA101312-ASE			No. E101110P9165		Cl. F IP 55		IEC60034-1
6306-2Z/C3		6205-2Z/C3				25 kg	
V	Hz	r/min	kW	A	Cos φ		
230 D	50	2930	3	10	0,83		
400 Y	50	2930	3	5,8	0,83		
415 Y	50	2940	3	5,8	0,8		
IE2-87,6(100%)-87,1(75%)-85(50%)						2009	

M000524

## Motor sizes 160 to 180

<b>ABB</b> 3~ Motor M3AA 180 MLB 4						IE2 CE	
3GAA182032-ADG			No. 3GV0912345678001		Cl. F IP 55		IEC 60034-1
V	Hz	kW	r/min	A	cos φ	duty	
690 Y	50	22	1475	24,0	0,83	S1	
400 Δ	50	22	1475	41,5	0,83	S1	
415 Δ	50	22	1477	40,4	0,81	S1	
Prod.code 3GAA182032-ADG						No 3GV0912345678001	
50 Hz: IE2 - 92,1(100%) - 93,1(75%) - 93,0(50%)						2009	
6313-2Z/C3		6212-2Z/C3				188 kg	
spare-parts:www.abb.com/partsonline							

M000502

## Motor sizes 200 to 280

<b>ABB</b> 3~Motor M3AA 225 SMA 4						IE2 CE	
3GAA222031-ADG			No. 3GV0923456789001		Cl. F IP 55		
6313-2Z/C3		6212-2Z/C3				240 kg	
V	Hz	kW	r/min	A	cos φ	duty	
690 Y	50	37	1479	39,2	0,84	S1	
400 Δ	50	37	1479	68	0,84	S1	
415 Δ	50	37	1481	68	0,81	S1	
50 Hz: IE2 - 93,4(100%) - 93,9(75%) - 93,4(50%)						2009	
Prod.code 3GAA222031-ADG							
6313-2Z/C3		6212-2Z/C3				240 kg	
spare-parts:www.abb.com/partsonline						IEC 60034-1	

M000503



# Ordering information

When placing an order, please state the following minimum data in the order, as in the example.

The product code of the motor is composed in accordance with the following example.

<b>Motor type</b>	<b>M3AA 112 MB</b>
<b>Pole number</b>	<b>4</b>
<b>Mounting arrangement (IM-code)</b>	<b>IM B3 (IM 1001)</b>
<b>Rated output</b>	<b>4 kW</b>
<b>Product code</b>	<b>3GAA 112312-ADE</b>
<b>Variant codes if needed</b>	

## Motor size

A	B	C	D, E, F
<b>M3AA</b>	<b>112 MB</b>	<b>3GAA 112 312</b>	<b>- ADE, 122, 003, etc.</b>
		1   2   3   4   5   6   7   8   9   10   11   12   13   14...	
A Motor type	B Motor size	D Code for mounting arrangement	E Voltage and frequency code
C Product code			F Generation code followed by variant codes

## Explanation of the product code

### Positions 1 to 4

**3GAA** = Totally enclosed motor with aluminum stator frame

### Position 4

#### Type of rotor

**A** = Squirrel cage rotor

### Positions 5 and 6

#### IEC size

**06** = 63

**07** = 71

**08** = 80

**09** = 90

**10** = 100

**11** = 112

**13** = 132

**16** = 160

**18** = 180

**20** = 200

**22** = 225

**25** = 250

**28** = 280

### Position 7

#### Pole pairs

**1** = 2 poles

**2** = 4 poles

**3** = 6 poles

**4** = 8 poles

**5** = 10 poles

**6** = 12 poles

**7** = > 12 poles

**8** = Two-speed motors

**9** = Multi-speed motors

### Positions 8 to 10

Running number

### Position 11

- (dash)

### Position 12

#### Mounting arrangement

**A** = Foot-mounted motor

**B** = Flange-mounted motor. Large flange with clearance holes.

**C** = Flange-mounted motor. Small flange with tapped holes.

**F** = Foot- and flange-mounted motor. Special flange.

**H** = Foot- and flange-mounted motor. Large flange with clearance holes.

**J** = Foot- and flange-mounted motor. Small flange with tapped holes.

**N** = Flange-mounted (CI ring flange FF)

**P** = Foot-and flange-mounted motor (CI ring flange FF)

**V** = Flange-mounted motor. Special flange.

### Position 13

#### Voltage and frequency code

##### Single-speed motors

**B** 380 VΔ 50 Hz

**D** 400 VΔ, 415 VΔ, 690 VY 50 Hz

**E** 500 VΔ 50 Hz

**F** 500 VY 50 Hz

**S** 230 VΔ, 400 VY, 415 VY 50 Hz

**T** 660 VΔ 50 Hz

**U** 690 VΔ 50 Hz

**X** Other rated voltage, connection or frequency, 690 V maximum

##### Two-speed motors

**A** 220 V 50 Hz

**B** 380 V 50 Hz

**D** 400 V 50 Hz

**E** 500 V 50 Hz

**S** 230 V 50 Hz

**X** Other rated voltage, connection or frequency, 690 V maximum

**Remark:** For voltage code X the variant code '209 Non-standard voltage or frequency (special winding)' must be ordered.

### Position 14

Version **A,B,C...** = Generation code followed by variant codes





# Industrial performance aluminum motors

## Technical data for totally enclosed squirrel cage three phase motors

IE2

P 55 - IC 411 - Insulation class F, temperature rise class B  
IE2 efficiency class according to IEC 60034-30; 2008

Output kW	Motor type	Product code	Speed r/min	Efficiency IEC 60034-2-1; 2007			Power factor cos φ	Current		Torque			Moment of inertia J = 1/4 GD <sup>2</sup> kgm <sup>2</sup>	Weight kg	Sound pressure level L <sub>PA</sub> dB
				Full load 100%	3/4 load 75%	1/2 load 50%		I <sub>N</sub> A	I <sub>s</sub> / I <sub>N</sub>	T <sub>N</sub> Nm	T <sub>l</sub> / T <sub>N</sub>	T <sub>b</sub> / T <sub>N</sub>			
<b>1000 r/min = 6-poles 400 V 50 Hz</b>			<b>GENELEC-design</b>												
0.09	M3AA 63 A	3GAA 063 311-••C	910	47.1	42.5	32.1	0.56	0.49	2.1	0.94	2.1	2.1	0.0002	4	38
0.12	M3AA 63 B	3GAA 063 312-••C	910	57.5	54.0	46.2	0.58	0.51	2.1	1.25	2.1	2.1	0.00027	4.5	38
0.18	M3AA 71 A	3GAA 073 311-••E	895	60.4	60.0	55.0	0.73	0.58	3.1	1.92	1.9	2.0	0.00092	5.5	42
0.25	M3AA 71 B	3GAA 073 312-••E	895	64.0	63.6	59.5	0.71	0.79	3.3	2.6	2.2	2.2	0.0012	6.5	42
0.37	M3AA 80 A	3GAA 083 311-••E	910	69.9	71.4	68.8	0.73	1.04	3.6	3.8	1.6	2.0	0.002	9	47
0.55	M3AA 80 B	3GAA 083 312-••E	905	72.1	73.4	71.2	0.69	1.59	3.3	5.8	1.8	1.9	0.0026	10	47
0.75	M3AA 90 LB	3GAA 093 313-••E	930	77.6	76.2	75.6	0.71	1.96	4.0	7.7	2.0	2.3	0.0048	18	44
1.1	M3AA 90 LD	3GAA 093 314-••E	930	78.1	78.6	76.4	0.66	3	4.0	11.2	1.9	2.3	0.0056	20	44
1.5	M3AA 100 LC	3GAA 103 312-••E	945	80.3	81.4	80.7	0.73	3.6	3.9	15.1	1.7	2.0	0.009	26	49
2.2	M3AA 112 MB	3GAA 113 312-••E	940	81.8	83.1	82.5	0.73	5.3	4.4	22.3	1.8	2.2	0.01	28	56
3	M3AA 132 S	3GAA 133 311-••E	960	83.3	83.6	81.7	0.65	7.9	4.3	29.8	1.6	2.3	0.031	39	57
4	M3AA 132 MA	3GAA 133 312-••E	960	84.9	85.3	83.9	0.68	10	4.6	39.7	1.5	2.2	0.038	46	61
5.5	M3AA 132 MC	3GAA 133 314-••E	965	86.1	86.1	84.3	0.67	13.7	6.2	54.4	2.5	2.8	0.049	59	61
7.5	M3AA 160 MLA	3GAA 163 031-••G	975	88.6	89.9	89.7	0.79	15.4	7.4	73.4	1.7	3.2	0.087	98	59
11	M3AA 160 MLB	3GAA 163 032-••G	972	89.3	90.7	90.6	0.79	22.5	7.5	108	1.9	2.9	0.114	125	59
15	M3AA 180 MLA	3GAA 183 031-••G	981	90.5	91.4	91.0	0.77	31	6.5	146	1.8	2.8	0.192	162	59
18.5	M3AA 200 MLA	3GAA 203 031-••G	988	91.6	92.3	91.7	0.80	36.4	6.7	178	2.3	2.9	0.382	196	63
22	M3AA 200 MLB	3GAA 203 032-••G	987	92.0	93.0	92.8	0.82	42	6.6	212	2.2	2.8	0.448	218	63
30	M3AA 225 SMA	3GAA 223 031-••G	986	92.7	93.3	92.9	0.83	56.2	7.0	290	2.6	2.9	0.663	266	63
37	M3AA 250 SMA	3GAA 253 031-••G	989	93.1	93.8	93.4	0.82	69.9	6.8	357	2.4	2.7	1.13	294	63
45 <sup>1)</sup>	M3AA 280 SMA	3GAA 283 031-••G	988	93.2	94.0	93.9	0.84	82.9	6.8	434	2.4	2.6	1.369	378	63
55 <sup>1)</sup>	M3AA 280 SMB	3GAA 283 032-••G	988	93.2	94.1	94.0	0.84	101	7.1	531	2.6	2.8	1.5	404	63
<b>1000 r/min = 6-poles 400 V 50 Hz</b>			<b>High-output design</b>												
0.37	M3AA 71 C	3GAA 073 003-••E	870	61.5	61.2	59.0	0.72	1.2	3.1	4	2.5	2.4	0.0015	7	44
0.75 <sup>1)2)</sup>	M3AA 80 C	3GAA 083 003-••E	905	70.1	70.3	69.1	0.76	2	3.9	7.9	2.5	2.4	0.0031	11	47
1.3 <sup>1)2)</sup>	M3AA 90 LB	3GAA 093 003-••E	910	74.4	72.6	68.7	0.71	3.5	4.0	13.6	1.9	2.2	0.0048	18	44
2.2 <sup>1)2)</sup>	M3AA 100 LC	3GAA 103 002-••E	940	78.0	74.0	71.2	0.71	5.7	4.5	22.3	1.9	2.3	0.009	26	49
3 <sup>1)2)</sup>	M3AA 112 MB	3GAA 113 102-••E	920	79.7	80.5	80.3	0.75	7.2	3.8	31.1	1.9	2.2	0.0126	32	76
15 <sup>2)</sup>	M3AA 160 MLC	3GAA 163 033-••G	967	88.7	90.5	90.5	0.76	32.1	6.3	148	2.0	2.9	0.131	138	59
18.5 <sup>1)2)</sup>	M3AA 180 MLB	3GAA 183 032-••G	970	88.8	90.7	90.7	0.75	40	5.1	182	1.6	2.5	0.213	175	59
30 <sup>1)</sup>	M3AA 200 MLC	3GAA 203 033-••G	985	92.0	93.1	92.9	0.83	56.7	6.9	290	2.3	2.8	0.531	245	63
37	M3AA 225 SMB	3GAA 223 034-••G	985	93.1	94.0	94.0	0.83	69.1	6.6	358	2.3	2.6	0.821	300	63
45 <sup>1)</sup>	M3AA 250 SMB	3GAA 253 032-••G	989	93.4	94.1	93.9	0.83	83.7	7.0	434	2.5	2.7	1.369	341	63
45 <sup>1)</sup>	M3AA 225 SMC	3GAA 223 033-••G	984	92.7	93.9	94.0	0.83	84.4	6.4	436	2.3	2.6	0.821	300	63
55 <sup>1)</sup>	M3AA 250 SMC	3GAA 253 033-••G	988	93.2	94.1	94.0	0.84	101	7.1	531	2.6	2.8	1.5	367	63

<sup>1)</sup> Temperature rise class F

<sup>2)</sup> Efficiency level IE1

The two bullets in the product code indicate choice of mounting arrangements, voltage and frequency code (see ordering information page).

I<sub>s</sub> / I<sub>N</sub> = Starting current  
T<sub>l</sub> / T<sub>N</sub> = Locked rotor torque  
T<sub>b</sub> / T<sub>N</sub> = Breakdown torque

Efficiency values are given according to IEC 60034-2-1; 2007.

Please note that the values are not comparable without knowing the testing method.

ABB has calculated the efficiency values according to indirect method, stray load losses (additional losses) determined from measuring.

# Industrial performance aluminum motors

## Technical data for totally enclosed squirrel cage three phase motors

P 55 - IC 411 - Insulation class F, temperature rise class B  
IE2 efficiency class according to IEC 60034-30; 2008

Output kW	Motor type	Product code	Speed r/min	Efficiency IEC 60034-2-1; 2007			Power factor cos φ	Current		Torque			Moment of inertia J = 1/4 GD <sup>2</sup> kgm <sup>2</sup>	Weight kg	Sound pressure level L <sub>PA</sub> dB
				Full load 100%	3/4 load 75%	1/2 load 50%		I <sub>N</sub> A	I <sub>s</sub> / I <sub>N</sub>	T <sub>N</sub> Nm	T <sub>l</sub> / T <sub>N</sub>	T <sub>b</sub> / T <sub>N</sub>			
<b>750 r/min = 8-poles 400 V 50 Hz</b>			<b>GENELEC-design</b>												
0.09	M3AA 71 A	3GAA 074 001-••E	660	49.4	46.0	38.5	0.59	0.44	2.0	1.3	2.4	2.3	0.00092	5.5	40
0.12	M3AA 71 B	3GAA 074 002-••E	670	51.4	47.5	39.9	0.56	0.6	2.1	1.71	2.8	2.4	0.0012	6.5	43
0.18	M3AA 80 A	3GAA 084 001-••E	685	63.5	62.0	56.3	0.62	0.65	2.8	2.5	1.6	2.0	0.0018	8.5	45
0.25	M3AA 80 B	3GAA 084 002-••E	685	67.1	67.2	63.4	0.63	0.85	2.8	3.4	1.4	1.9	0.0024	9.5	50
0.37	M3AA 90 S	3GAA 094 001-••E	695	59.4	56.3	49.1	0.54	1.66	2.7	5	1.6	2.1	0.0032	13	52
0.55	M3AA 90 L	3GAA 094 002-••E	660	59.1	59.5	55.2	0.58	2.3	2.1	7.9	1.5	1.6	0.0043	16	52
0.75	M3AA 100 LA	3GAA 104 001-••E	720	70.7	67.1	59.9	0.47	3.2	3.9	9.9	2.8	3.6	0.0069	20	46
1.1	M3AA 100 LB	3GAA 104 002-••E	695	76.0	76.5	74.6	0.66	3.1	3.4	15.1	1.7	2.2	0.0082	23	53
1.5	M3AA 112 M	3GAA 114 101-••E	690	74.4	75.9	74.1	0.70	4.1	3.2	20.7	1.4	1.9	0.01	28	55
2.2	M3AA 132 S	3GAA 134 001-••E	715	82.9	83.0	80.8	0.62	6.1	3.4	29.3	1.3	1.9	0.0038	46	56
3	M3AA 132 M	3GAA 134 002-••E	715	79.9	80.8	79.1	0.64	8.4	3.2	40	1.2	1.8	0.0045	53	58
4	M3AA 160 MLA	3GAA 164 031-••G	728	84.1	85.1	83.7	0.67	10.2	5.4	52.4	1.5	2.6	0.068	84	59
5.5	M3AA 160 MLB	3GAA 164 032-••G	726	84.7	86.0	84.9	0.67	13.9	5.6	72.3	1.4	2.6	0.085	98	59
7.5	M3AA 160 MLC	3GAA 164 033-••G	727	86.1	87.3	86.6	0.65	19.3	4.7	98.5	1.5	2.8	0.132	137	59
11	M3AA 180 MLA	3GAA 184 031-••G	731	86.8	88.4	87.8	0.67	27.3	4.4	143	1.8	2.6	0.214	175	59
15	M3AA 200 MLA	3GAA 204 031-••G	737	90.2	91.3	90.9	0.74	32.4	5.3	194	2.0	2.4	0.45	217	60
18.5	M3AA 225 SMA	3GAA 224 031-••G	739	91.0	92.0	91.5	0.73	40.1	5.2	239	2.0	2.3	0.669	266	63
22	M3AA 225 SMB	3GAA 224 032-••G	738	91.6	92.4	92.0	0.74	46.8	5.5	284	2.0	2.3	0.722	279	63
30	M3AA 250 SMA	3GAA 254 031-••G	742	92.4	92.9	92.3	0.71	66	5.8	386	2.6	2.4	1.404	340	63
37	M3AA 280 SMA	3GAA 284 031-••G	740	92.3	93.0	92.7	0.74	78.1	5.6	477	2.4	2.3	1.505	403	63
<b>750 r/min = 8-poles 400 V 50 Hz</b>			<b>High-output design</b>												
0.18 <sup>1)</sup>	M3AA 71 C	3GAA 074 003-••E	660	47.2	44.8	45.0	0.66	0.83	2.2	2.6	2.3	2.2	0.0015	7	40
0.37 <sup>1)</sup>	M3AA 80 C	3GAA 084 003-••E	700	57.5	56.0	55.0	0.62	1.49	3.3	5	2.5	2.5	0.0031	11	45
0.75 <sup>1)</sup>	M3AA 90 LB	3GAA 094 003-••E	680	63.1	59.8	53.0	0.60	2.8	3.0	10.5	1.8	2.0	0.0048	18	43
1.5 <sup>1)</sup>	M3AA 100 LC	3GAA 104 003-••E	670	70.0	65.2	63.8	0.70	4.4	3.3	21.3	1.8	2.2	0.009	26	46
2 <sup>1)</sup>	M3AA 112 MB	3GAA 114 102-••E	685	73.2	72.5	70.0	0.69	5.7	3.4	27.8	2.1	2.3	0.0126	32	52

<sup>1)</sup> Temperature rise class F

The two bullets in the product code indicate choice of mounting arrangements, voltage and frequency code (see ordering information page).

I<sub>s</sub> / I<sub>N</sub> = Starting current  
T<sub>l</sub> / T<sub>N</sub> = Locked rotor torque  
T<sub>b</sub> / T<sub>N</sub> = Breakdown torque

Efficiency values are given according to IEC 60034-2-1; 2007.

Please note that the values are not comparable without knowing the testing method.

ABB has calculated the efficiency values according to indirect method, stray load losses (additional losses) determined from measuring.

# Industrial performance aluminum motors – variant codes

Code <sup>1)</sup>	Variant code	Frame Size											
		63	71	80	90	100	112	132	160	180	200	225	250
<b>Balancing</b>													
417	Vibration acc. to Grade B (IEC 60034-14).	NA	NA	NA	P	P	P	P	R	R	R	R	R
423	Balanced without key.	P	P	P	P	P	P	P	P	P	P	P	P
424	Full key balancing.	P	P	P	P	P	P	P	P	P	P	P	P
<b>Bearings and Lubrication</b>													
036	Transport lock for bearings.	NA	NA	NA	M	M	M	M	M	M	M	M	M
037	Roller bearing at D-end.	NA	NA	NA	P	P	P	P	M	M	M	M	M
039	Cold resistant grease.	M	M	M	M	M	M	M	NA	NA	NA	NA	NA
040	Heat resistant grease.	M	M	M	M	M	M	M	NA	NA	NA	NA	NA
041	Bearings regreasable via grease nipples.	NA	NA	NA	P	P	P	P	M	M	M	M	S
042	Locked drive-end.	S	S	S	S	S	S	S	S	S	S	S	S
043	SPM compatible nipples for vibration measurement	NA	NA	NA	R	R	R	R	M	M	M	M	M
057	2RS bearings at both ends.	M	M	M	M	M	M	M	M	M	M	M	M
058	Angular contact bearing at D-end, shaft force away from bearing.	NA	NA	NA	M	M	M	M	M	M	M	M	M
059	Angular contact bearing at N-end, shaft force towards bearing.	NA	NA	NA	M	M	M	M	M	M	M	M	M
188	63-series bearings.	NA	NA	NA	M	S	S	M	S	S	S	S	S
194	2Z bearings greased for life at both ends.	S	S	S	S	S	S	S	S	S	S	S	M
195	Bearings greased for life.	S	S	S	S	S	S	S	S	S	S	S	NA
796	Grease nipples JIS B 1575 PT 1/8 Type A	NA	NA	NA	NA	NA	NA	NA	M	M	M	M	M
797	Stainless steel SPM Nipples	NA	NA	NA	R	R	R	R	M	M	M	M	M
798	Stainless steel grease nipples	NA	NA	NA	NA	NA	NA	NA	M	M	M	M	M
<b>Branch standard designs</b>													
071	Cooling Tower duty	NA	NA	NA	NA	NA	R	R	P	P	P	P	P
079	Silumin-alloy rotor cage.	P	P	P	P	P	P	P	NA	NA	NA	NA	NA
142	“Manilla connection”.	P	P	P	P	P	P	P	P	P	P	P	P
178	Stainless steel / acid proof bolts.	M	M	M	M	M	M	M	M	M	M	M	M
209	Non-standard voltage or frequency, (special winding).	P	P	P	P	P	P	P	P	P	P	P	P
217	Cast iron D-end shield (on aluminum motor).	NA	NA	NA	M	M	M	M	S	S	S	S	S
425	Corrosion protected stator and rotor core.	P	P	P	P	P	P	P	P	P	P	P	P
785	Reinforced tropicalisation.	NA	NA	NA	NA	NA	NA	NA	P	P	P	P	P
<b>Cooling system</b>													
053	Metal fan cover.	S	M	M	M	M	M	M	S	S	S	S	S
068	Light alloy metal fan	R	M	M	M	M	M	M	M	M	M	M	M
075	Cooling method IC418 (without fan).	R	R	R	P	P	P	P	M	M	M	M	M
183	Separate motor cooling (fan axial, N-end).	NA	M	M	M	M	M	P	M	M	M	M	M
189	Separate motor cooling, IP44, 400V, 50Hz (fan axial, N-end).	NA	NA	NA	NA	NA	NA	NA	M	M	M	M	M
794	Fan for reduced noise level (4-p fan).	NA	NA	NA	NA	NA	NA	NA	R	R	R	R	R
<b>Coupling</b>													
035	Assembly of customer supplied coupling-half.	R	R	R	R	R	R	R	-	-	-	-	-
<b>Documentation</b>													
141	Binding dimension drawing.	R	R	R	R	R	R	R	M	M	M	M	M
<b>Drain holes</b>													
065	Plugged existing drain holes.	M	M	M	M	M	M	M	M	M	M	M	M
<b>Earthing Bolt</b>													
067	External earthing bolt.	M	M	M	M	M	M	M	M	M	M	M	M
<b>Hazardous Environments</b>													
See catalog “Motors for hazardous Environments” for details													
<b>Heating elements</b>													
450	Heating element, 100-120V.	M	M	M	M	M	M	M	M	M	M	M	M
451	Heating element, 200-240V.	M	M	M	M	M	M	M	M	M	M	M	M

<sup>1)</sup> Certain variant codes cannot be used simultaneously

S = Included as standard.  
M = On modification of a stocked motor, or on new manufacture, the number per order may be limited.  
P = New manufacture only.  
R = On request.  
NA = Not applicable.

Code <sup>1)</sup>	Variant code	Frame Size											
		63	71	80	90	100	112	132	160	180	200	225	250
<b>Insulation system</b>													
014	Winding insulation class H.	R	R	R	P	P	P	P	P	P	P	P	P
405	Special winding insulation for frequency converter supply.	R	R	R	R	R	R	R	P	P	P	P	P
406	Winding for supply >690<=1000 Volts.	NA	NA	NA	NA	NA	NA	NA	NA	NA	P	P	P
<b>Marine motors</b>													
See catalog "Marine Motors" for details													
<b>Mounting arrangements</b>													
007	IM 3001 flange mounted, IEC flange, from IM 1001 (B5 from B3).	NA	NA	NA	NA	NA	NA	NA	M	M	M	M	M
008	IM 2101 foot/flange mounted, IEC flange, from IM 1001 (B34 from B3).	M	M	M	M	M	M	M	M	NA	NA	NA	NA
009	IM 2001 foot/flange mounted, IEC flange, from IM 1001 (B35 from B3).	M	M	M	M	M	M	M	M	M	M	M	M
047	IM 3601 flange mounted, IEC flange, from IM 3001 (B14 from B5).	M	M	M	M	M	M	M	M	NA	NA	NA	NA
048	IM 3001 flange mounted, IEC flange, from IM 3601 (B5 from B14).	M	M	M	M	M	M	M	NA	NA	NA	NA	NA
066	Modified for non-standard mounting position (please specify IM xxxx), (must be ordered for all mounting arrangements excluding IM B3 (1001), IM B5 (3001), IM B35 (2001), B34 (2101) & B14 (3601).	M	M	M	M	M	M	M	M	M	M	M	M
078	(IM 3601) Flange mounted, DIN C-flange.	NA	NA	NA	R	NA	NA	NA	NA	NA	NA	NA	NA
116	Special flange.	R	R	R	R	R	NA	NA	NA	NA	NA	NA	NA
200	Flange ring holder.	NA	M	M	M	M	M	M	NA	NA	NA	NA	NA
218	Flange ring FT 85.	NA	M	M	M	NA	NA	NA	NA	NA	NA	NA	NA
219	Flange ring FT 100.	NA	M	M	M	NA	NA	NA	NA	NA	NA	NA	NA
220	Flange ring FF 100.	NA	M	M	M	NA	NA	NA	NA	NA	NA	NA	NA
223	Flange ring FF 115.	NA	M	M	M	NA	NA	NA	NA	NA	NA	NA	NA
224	Flange ring FT 115.	NA	M	M	M	M	M	NA	NA	NA	NA	NA	NA
226	Flange ring FF 130.	NA	M	M	M	M	M	NA	NA	NA	NA	NA	NA
227	Flange ring FT 130.	NA	M	M	M	M	M	NA	NA	NA	NA	NA	NA
229	Flange FT 130.	NA	NA	NA	NA	M	M	NA	NA	NA	NA	NA	NA
233	Flange ring FF 165.	NA	M	M	M	M	M	NA	NA	NA	NA	NA	NA
234	Flange ring FT 165.	NA	M	M	M	M	M	NA	NA	NA	NA	NA	NA
235	Flange FF 165.	NA	NA	NA	M	NA	NA	NA	NA	NA	NA	NA	NA
236	Flange FT 165.	NA	NA	NA	NA	NA	NA	M	NA	NA	NA	NA	NA
243	Flange ring FF 215.	NA	NA	NA	NA	M	M	M	NA	NA	NA	NA	NA
244	Flange ring FT 215.	NA	NA	NA	NA	M	M	M	NA	NA	NA	NA	NA
245	Flange FF 215.	NA	NA	NA	NA	M	M	NA	NA	NA	NA	NA	NA
253	Flange ring FF 265.	NA	NA	NA	NA	NA	NA	M	NA	NA	NA	NA	NA
254	Flange ring FT 265.	NA	NA	NA	NA	NA	NA	M	NA	NA	NA	NA	NA
255	Flange FF 265.	NA	NA	NA	NA	NA	NA	M	NA	NA	NA	NA	NA
260	Flange FT 115.	NA	NA	NA	M	NA	NA	NA	NA	NA	NA	NA	NA
306	IM 1001 foot mounted, from IM 3601 (B3 from B14).	M	M	M	M	M	M	M	NA	NA	NA	NA	NA
307	IM 2101 foot/flange mounted, IEC flange, from IM 3601 (B34 from B14).	M	M	M	M	M	M	M	NA	NA	NA	NA	NA
308	IM 2001 foot/flange mounted, IEC flange, from IM 3601 (B35 from B14).	M	M	M	M	M	M	M	NA	NA	NA	NA	NA
309	IM 1001 foot mounted, from IM 3001 (B3 from B5).	M	M	M	M	M	M	M	NA	NA	NA	NA	NA
310	IM 2101 foot/flange mounted, IEC flange, from IM 3001 (B34 from B5).	M	M	M	M	M	M	M	NA	NA	NA	NA	NA
311	IM 2001 foot/flange mounted, IEC flange, from IM 3001 (B35 from B5).	M	M	M	M	M	M	M	NA	NA	NA	NA	NA
312	IM 1001 foot mounted, from IM 2101 (B3 from B34).	M	M	M	M	M	M	M	NA	NA	NA	NA	NA

<sup>1)</sup> Certain variant codes cannot be used simultaneously

S = Included as standard.  
M = On modification of a stocked motor, or on new manufacture, the number per order may be limited.  
P = New manufacture only.  
R = On request.  
NA = Not applicable.

Code <sup>1)</sup>	Variant code	Frame Size												
		63	71	80	90	100	112	132	160	180	200	225	250	280
315	IM 2001 foot/flange mounted, IEC flange, from IM 2101 (B35 from B34).	M	M	M	M	M	M	M	NA	NA	NA	NA	NA	NA
316	IM 1001 foot mounted, from IM 2001 (B3 from B35).	M	M	M	M	M	M	M	NA	NA	NA	NA	NA	NA
319	IM 2101 foot/flange mounted, IEC flange, from IM 2001 (B34 from B35).	M	M	M	M	M	M	M	NA	NA	NA	NA	NA	NA
<b>Noise reduction</b>														
055	Noise reducing cover.	NA	NA	NA	NA	NA	NA	NA	-	-	-	-	-	-
<b>Painting</b>														
114	Special paint colour, standard grade.	M/P	P	P	P	P	P	P	M	M	M	M	M	M
168	Primer paint only.	NA	NA	NA	P	P	P	P	NA	NA	NA	NA	NA	NA
179	Special paint specification.	R	R	R	R	R	R	R	R	R	R	R	R	R
<b>Protection</b>														
005	Metal protective roof, vertical motor, shaft down.	M	M	M	M	M	M	M	M	M	M	M	M	M
072	Radial seal at D-end.	M	M	M	M	M	M	M	M	M	M	M	M	M
158	Degree of protection IP65.	M	M	M	M	M	M	M	M	M	M	M	M	M
211	Weather protected, IP xx W	NA	NA	NA	P	P	P	P	M	M	M	M	M	M
403	Degree of protection IP56.	M	M	M	M	M	M	M	M	M	M	M	M	M
404	Degree of protection IP56, without fan and fan cover.	NA	NA	NA	P	P	P	P	NA	NA	NA	NA	NA	NA
784	Gamma-seal at D-end.	NA	NA	NA	M	M	M	M	M	M	M	M	M	M
<b>Rating &amp; instruction plates</b>														
002	Restamping voltage, frequency and output, continuous duty.	M	M	M	M	M	M	M	M	M	M	M	M	M
003	Individual serial number.	M	M	M	M	M	M	M	S	S	S	S	S	S
004	Additional text on std rating plate (max 12 digits on free text line).	NA	NA	NA	M	M	M	M	M	M	M	M	M	M
095	Restamping output (maintained voltage, frequency), intermittent duty.	M	M	M	M	M	M	M	M	M	M	M	M	M
098	Stainless rating plate.	M	M	M	M	M	M	M	M	M	M	M	M	M
135	Mounting of additional identification plate, stainless.	M	M	M	M	M	M	M	NA	NA	NA	NA	NA	NA
138	Mounting of additional identification plate, aluminium.	M	M	M	M	M	M	M	M	M	M	M	M	M
139	Additional identification plate delivered loose.	M	M	M	M	M	M	M	M	M	M	M	M	M
160	Additional rating plate affixed.	P	P	P	M	M	M	M	M	M	M	M	M	M
161	Additional rating plate delivered loose.	M	M	M	M	M	M	M	M	M	M	M	M	M
163	Frequency converter rating plate. Rating data according to quotation.	R	R	R	R	R	R	R	M	M	M	M	M	M
198	Aluminum rating plate.	S	S	S	S	S	S	M	S	S	S	S	S	S
<b>Shaft &amp; rotor</b>														
069	Two shaft extensions as per basic catalogue.	NA	NA	NA	P	P	P	P	P	P	P	P	P	P
070	One or two special shaft extensions, standard shaft material.	NA	NA	NA	P	P	P	R	R	R	R	R	R	R
131	Motor delivered with half key (Key not exceeding shaft diameter)	NA	NA	NA	NA	NA	NA	NA	M	M	M	M	M	M
155	Cylindrical shaft extension, D-end, without key-way.	NA	NA	NA	R	R	R	R	NA	NA	NA	NA	NA	NA
165	Shaft extension with open key-way.	NA	NA	NA	NA	NA	NA	NA	P	P	P	P	P	P
410	Stainless steel shaft (standard or non-standard design).	NA	NA	NA	P	P	P	P	P	P	P	P	P	P
<b>Standards and Regulations</b>														
010	Fulfilling CSA Safety Certificate.	P	P	P	P	P	P	NA	M	M	M	M	M	M
011	Fulfilling CSA Energy Efficiency Verification (code 010 included).	NA	NA	NA	NA	NA	NA	NA	M	M	M	M	M	M
408	Fulfilling EPAAct certification requirements, CC031A.	NA	NA	NA	R	R	NA	NA	NA	NA	NA	NA	NA	NA
500	Fulfilling Korean MEPS efficiency regulations	NA	NA	NA	NA	NA	NA	NA	R	R	R	R	R	R
540	China energy label	NA	NA	NA	NA	NA	NA	NA	R	R	R	R	R	R
778	GOST Export/Import Certificate (Russia).	NA	NA	NA	M	M	M	M	M	M	M	M	M	M
779	SASO Export/Import Certificate (Saudi Arabia)	NA	NA	NA	NA	NA	NA	NA	M	M	M	M	M	M

<sup>1)</sup> Variant codes cannot be used simultaneously

S = Included as standard.  
M = On modification of a stocked motor, or on new manufacture,  
the number per order may be limited.  
P = New manufacture only.  
R = On request.  
NA = Not applicable.



Code <sup>1)</sup>	Variant code	Frame Size												
		63	71	80	90	100	112	132	160	180	200	225	250	280
<b>Stator winding temperature sensors</b>														
120	KTY 84-130 (1 per phase) in stator winding.	NA	NA	NA	NA	NA	NA	NA	R	R	R	R	R	R
121	Bimetal detectors, break type (NCC), (3 in series), 130°C, in stator winding.	M	M	M	M	M	M	M	M	M	M	M	M	M
122	Bimetal detectors, break type (NCC), (3 in series), 150°C, in stator winding.	M	M	M	M	M	M	M	M	M	M	M	M	M
123	Bimetal detectors, break type (NCC), (3 in series), 170°C, in stator winding.	M	M	M	M	M	M	M	M	M	M	M	M	M
124	Bimetal detectors, break type (NCC), (3 in series), 140°C, in stator winding.	NA	NA	NA	NA	NA	NA	NA	M	M	M	M	M	M
125	Bimetal detectors, break type (NCC), (2x3 in series), 150°C, in stator winding.	NA	NA	NA	M	M	M	M	M	M	M	M	M	M
127	Bimetal detectors, break type (NCC), (3 in series, 130°C & 3 in series, 150°C), in stator winding.	NA	NA	NA	M	M	M	M	M	M	M	M	M	M
321	Bimetal detectors, closing type (NO), (3 in parallel), 130°C, in stator winding.	M	M	M	M	M	M	M	NA	NA	NA	NA	NA	NA
322	Bimetal detectors, closing type (NO), (3 in parallel), 150°C, in stator winding.	M	M	M	M	M	M	M	NA	NA	NA	NA	NA	NA
323	Bimetal detectors, closing type (NO), (3 in parallel), 170°C, in stator winding.	NA	NA	NA	P	P	P	P	NA	NA	NA	NA	NA	NA
325	Bimetal detectors, closing type (NO), (2x3 in parallel), 150°C, in stator winding.	NA	NA	NA	P	P	M	M	NA	NA	NA	NA	NA	NA
327	Bimetal detectors, closing type (NO), (3 in parallel, 130°C & 3 in parallel, 150°C), in stator winding.	NA	NA	NA	P	P	M	M	NA	NA	NA	NA	NA	NA
435	PTC - thermistors (3 in series), 130°C, in stator winding.	M	M	M	M	M	M	M	M	M	M	M	M	M
436	PTC - thermistors (3 in series), 150°C, in stator winding.	M	M	M	M	M	M	M	S	S	S	S	S	S
437	PTC - thermistors (3 in series), 170°C, in stator winding.	M	M	M	M	M	M	M	M	M	M	M	M	M
439	PTC - thermistors (2x3 in series), 150°C, in stator winding.	NA	NA	NA	M	M	M	M	M	M	M	M	M	M
440	PTC - thermistors (3 in series, 110°C & 3 in series, 130°C), in stator winding.	NA	NA	NA	P	P	P	P	NA	NA	NA	NA	NA	NA
441	PTC - thermistors (3 in series, 130°C & 3 in series, 150°C), in stator winding.	NA	NA	NA	M	M	M	M	M	M	M	M	M	M
442	PTC - thermistors (3 in series, 150°C & 3 in series, 170°C), in stator winding.	NA	NA	NA	P	P	M	M	M	M	M	M	M	M
445	Pt-100 2-wire in stator winding, 1 per phase	NA	NA	NA	P	P	P	P	M	M	M	M	M	M
446	Pt-100 2-wire in stator winding, 2 per phase	NA	NA	NA	R	R	R	R	M	M	M	M	M	M
<b>Terminal box</b>														
015	Motor supplied in D connection.	M	M	M	M	M	M	M	M	M	M	M	M	M
016	9 terminals in terminal box	NA	NA	NA	P	P	P	P	NA	NA	NA	NA	NA	NA
017	Motor supplied in Y connection.	M	M	M	M	M	M	M	M	M	M	M	M	M
019	Larger than standard terminal box.	NA	NA	NA	NA	NA	NA	NA	R	R	M	M	M	M
021	Terminal box LHS (seen from D-end).	NA	NA	NA	NA	NA	NA	NA	NA	NA	P	P	P	P
022	Cable entry LHS (seen from D-end).	NA	NA	NA	NA	NA	NA	NA	S	S	NA	NA	NA	NA
136	Extended cable connection, standard terminal box.	NA	NA	NA	P	P	P	P	NA	NA	NA	NA	NA	NA
013	Extended cable connection, low terminal box, "Flying leads".	NA	NA	NA	P	P	P	P	NA	NA	NA	NA	NA	NA
180	Terminal box RHS (seen from D-end).	NA	NA	NA	NA	NA	NA	NA	NA	NA	P	M	M	P
230	Standard metal cable glands.	M	M	M	M	M	M	M	M	M	M	M	M	M
375	Standard plastic cable gland	M	M	M	M	M	M	M	NA	NA	NA	NA	NA	NA
376	Two standard plastic cable glands	M	M	M	M	M	M	M	NA	NA	NA	NA	NA	NA
418	Separate terminal box for auxiliaries, standard material.	NA	NA	NA	NA	R	R	R	M	M	M	M	M	M
467	Lower than standard terminal box and rubber extended cable. Cable length 2m.	NA	NA	NA	NA	NA	NA	NA	P	P	P	P	P	P
729	Aluminum non-drilled flange for cable glands	NA	NA	NA	NA	NA	NA	NA	NA	NA	M	M	M	M

<sup>1)</sup> Certain variant codes cannot be used simultaneously

S = Included as standard.  
M = On modification of a stocked motor, or on new manufacture,  
the number per order may be limited.  
P = New manufacture only.  
R = On request.  
NA = Not applicable.

Code <sup>1)</sup>	Variant code	Frame Size												
		63	71	80	90	100	112	132	160	180	200	225	250	280
731	Two standard metal cable glands.	M	M	M	M	M	M	M	M	M	M	M	M	M
739	Prepared for metric cable glands according to DIN 42925, draft aug. 1999.	NA	NA	NA	NA	NA	NA	NA	NA	NA	M	M	M	NA
740	Prepared for PG cable glands.	NA	NA	NA	NA	NA	NA	NA	M	M	M	M	M	M
<b>Testing</b>														
140	Test confirmation.	M	M	M	M	M	M	M	M	M	M	M	M	M
145	Type test report from a catalogue motor, 400V 50Hz.	M	M	M	M	M	M	M	M	M	M	M	M	M
146	Type test with report for one motor from specific delivery batch.	M	M	M	M	M	M	M	M	M	M	M	M	M
147	Type test with report for motor from specific delivery batch, customer witnessed.	M	M	M	M	M	M	M	M	M	M	M	M	M
148	Routine test report.	M	M	M	M	M	M	M	M	M	M	M	M	M
149	Test according to separate test specification.	R	R	R	R	R	R	R	R	R	R	R	R	R
153	Reduced test for classification society.	M	M	M	M	M	M	M	M	M	M	M	M	M
221	Type test and multi-point load test with report for one motor from specific delivery batch.	M	M	M	M	M	M	M	M	M	M	M	M	M
222	Torque/speed curve, type test and multi-point load test with report for one motor from specific delivery batch.	NA	NA	NA	M	M	M	M	M	M	M	M	M	M
760	Vibration level test	M	M	M	M	M	M	M	M	M	M	M	M	M
762	Noise level test for one motor from specific delivery batch.	M	M	M	M	M	M	M	M	M	M	M	M	M
<b>Variable speed drives</b>														
470	Prepared for hollow shaft pulse tacho (L&L equivalent).	R	R	R	R	R	R	R	M	M	M	M	M	M
472	1024 pulse tacho (L&L 861007455-1024).	R	R	R	R	R	R	R	M	M	M	M	M	M
473	2048 pulse tacho (L&L 861007455-2048).	R	R	R	R	R	R	R	M	M	M	M	M	M
474	Separate motor cooling (fan axial, N-end) and prepared for hollow shaft tacho (L&L equivalent).	R	R	R	R	R	R	R	M	M	M	M	M	M
476	Separate motor cooling (fan axial, N-end) and 1024 pulse tacho (L&L 861007455-1024).	R	R	R	R	R	R	R	M	M	M	M	M	M
477	Separate motor cooling (fan axial, N-end) and 2048 pulse tacho (L&L 861007455-2048).	R	R	R	R	R	R	R	M	M	M	M	M	M
570	Prepared for hollow shaft pulse tacho (L&L 503).	R	R	R	R	R	R	R	M	M	M	M	M	M
572	1024 pulse tacho (L&L 503).	R	R	R	R	R	R	R	M	M	M	M	M	M
573	2048 pulse tacho (L&L 503).	R	R	R	R	R	R	R	M	M	M	M	M	M
574	Separate motor cooling (fan axial, N-end) and prepared for hollow shaft tacho (L&L 503).	R	R	R	R	R	R	R	M	M	M	M	M	M
576	Separate motor cooling (fan axial, N-end) and 1024 pulse tacho (L&L 503).	R	R	R	R	R	R	R	M	M	M	M	M	M
577	Separate motor cooling (fan axial, N-end) and 2048 pulse tacho (L&L 503).	R	R	R	R	R	R	R	M	M	M	M	M	M
580	Separate motor cooling, IP44, 400V, 50Hz (fan axial, N-end) and 1024 pulse tacho (L&L 503).	NA	NA	NA	NA	NA	NA	NA	M	M	M	M	M	M
581	Separate motor cooling, IP44, 400V, 50Hz (fan axial, N-end) and 2048 pulse tacho (L&L 503).	NA	NA	NA	NA	NA	NA	NA	M	M	M	M	M	M
661	1024 Pulse tacho mounted, Hohner series 59, 11-30V	NA	R	R	P	P	P	P	NA	NA	NA	NA	NA	NA
662	2048 Pulse tacho mounted, Hohner series 59, 11-30V	NA	R	R	P	P	P	P	NA	NA	NA	NA	NA	NA
701	Insulated bearing at N-end.	NA	NA	NA	NA	NA	NA	NA	P	P	M	M	M	M
704	EMC cable gland.	NA	NA	NA	M	M	M	M	M	M	M	M	M	M
<b>Y/Δ starting</b>														
117	Terminals for Y/Δ start at both speeds (two speed windings).	P	P	P	P	P	P	P	P	P	P	P	P	P

<sup>1)</sup> Certain variant codes cannot be used simultaneously

S = Included as standard.  
M = On modification of a stocked motor, or on new manufacture, the number per order may be limited.  
P = New manufacture only.  
R = On request.  
NA = Not applicable.

# Industrial performance aluminum motors M3AA 63 - 112

## Dimension drawings

Foot-mounted motor;  
IM B3 (IM 1001), IM 1002

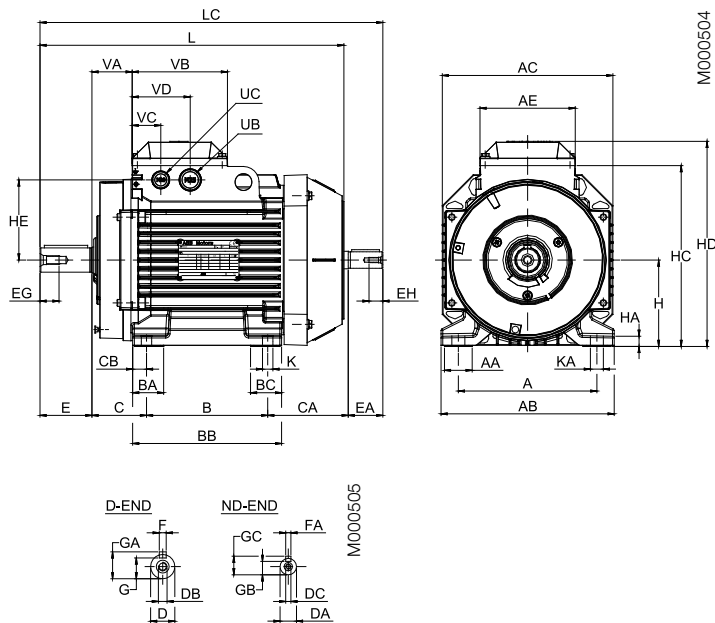

Flange-mounted motor, large flange;  
IM B5 (IM 3001), IM 3002

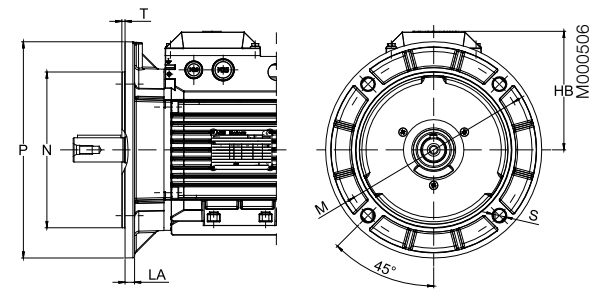

Flange-mounted motor, small flange;  
IM B14 (IM 3601)

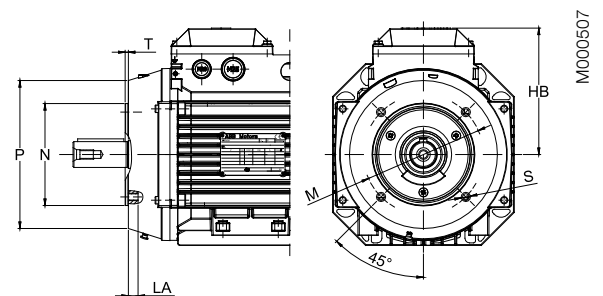

### IM B3 (IM 1001), IM 1002

Motor size	A	AA	AB	AC	AE	B	BA	BB	BC	C	CA	CB	D	DA	DB	DC	E	EA	EG	EH	F	FA
63	100	25	120	120	85	80	32	98	32	40	74	10	11	11	M4	M4	23	23	10	10	4	4
71	112	23	136	130	97	90	24.5	110	24.5	45	79.5	10	14	11	M5	M4	30	23	12.5	10	5	4
80	125	27	154	150	97	100	32	125	32	50	80.5	12.5	19	14	M6	M5	40	30	16	12.5	6	5
90S	140	27	170	177	110	100	32	125	32	56	83.5	12.5	24	14	M8	M5	50	30	19	12.5	8	5
90L	140	27	170	177	110	125	32	150	32	56	83.5	12.5	24	14	M8	M5	50	30	19	12.5	8	5
90 LD	140	27	170	177	110	125	32	150	32	56	105.5	12.5	24	14	M8	M5	50	30	19	12.5	8	5
100	160	32	200	197	110	140	36	172	36	63	93	16	28	19	M10	M6	60	40	22	16	8	6
112	190	32	230	197	110	140	36	172	36	70	136	16	28	19	M10	M6	60	40	22	16	8	6

Motor size	G	GA	GB	GC	H	HA	HC	HD	HE	K	KA	L	LC	UB	UC	VA	VB	VC	VD
63	8.5	12.5	8.5	12.5	63	7	120	151	50	7	11	214	237	pg11	M16x1.5	31	92	30.5	61.5
71	11	16	8.5	12.5	71	9	151	180	63.5	7	11	240	267	M20	M20	35			
80	15.5	21.5	11	16	80	10	164.5	193.5	68	10	10	265.5	300.5	M20	M20	37.5	97	30.5	66.5
90S	20	27	11	16	90	10	189	217	82.5	10	14	284.5	319.5	M25	M20	43.5	110	33	67
90L	20	27	11	16	90	10	189	217	82.5	10	14	309.5	344.5	M25	M20	43.5	110	33	67
90 LD	20	27	11	16	90	10	189	217	82.5	10	14	331.5	366.5	M25	M20	43.5	110	33	67
100	24	31	15.5	21.5	100	12	209	237	92.5	12	15	351	396	M25	M20	46.5	110	33	67
112	24	31	15.5	21.5	112	12	221	249	92.5	12	15	393	436	M25	M20	46.5	110	33	67

### IM B5 (IM3001), IM 3002

Motor size	HB	LA	M	N	P	S	T
63	103	10	100	80	120	7	3
71	109	9.5	130	130	160	10	3.5
80	113.5	10	165	130	200	12	3.5
90S	127	10	165	130	200	12	3.5
90L	127	10	165	130	200	12	3.5
90 LD	127	10	165	130	200	12	3.5
100	137	11	215	180	250	15	4
112	137	11	215	180	250	15	4

### IM B14 (IM 3601), IM 3602

Motor size	HB	LA	M	N	P	S	T
63	103	10	65	50	80	M5	2.5
71	109	11	85	70	105	M6	3
80	113.5	11	100	80	120	M6	3
90S	127	13	115	95	140	M8	3
90L	127	13	115	95	140	M8	3
90 LD	127	13	115	95	140	M8	3
100	137	14	130	110	160	M8	3.5
112	137	14	130	110	160	M8	3.5

Tolerances:

A, B	±0.8	H	+0 -0.5
D, DA	ISO j6	N	ISO j6
F, FA	ISO h9	C, CA	±0.8

Above table gives the main dimensions in mm.  
For detailed drawings please see our web-pages '[www.abb.com/motors&generators](http://www.abb.com/motors&generators)' or contact ABB.

# Industrial performance aluminum motors M3AA 63 - 112

## Dimension drawings

Foot- and flange-mounted motor;  
IM B35 (IM 2001), IM 2002, large flange

Foot- and flange-mounted motor;  
IM B34 (IM 2101), IM 2102, small flange

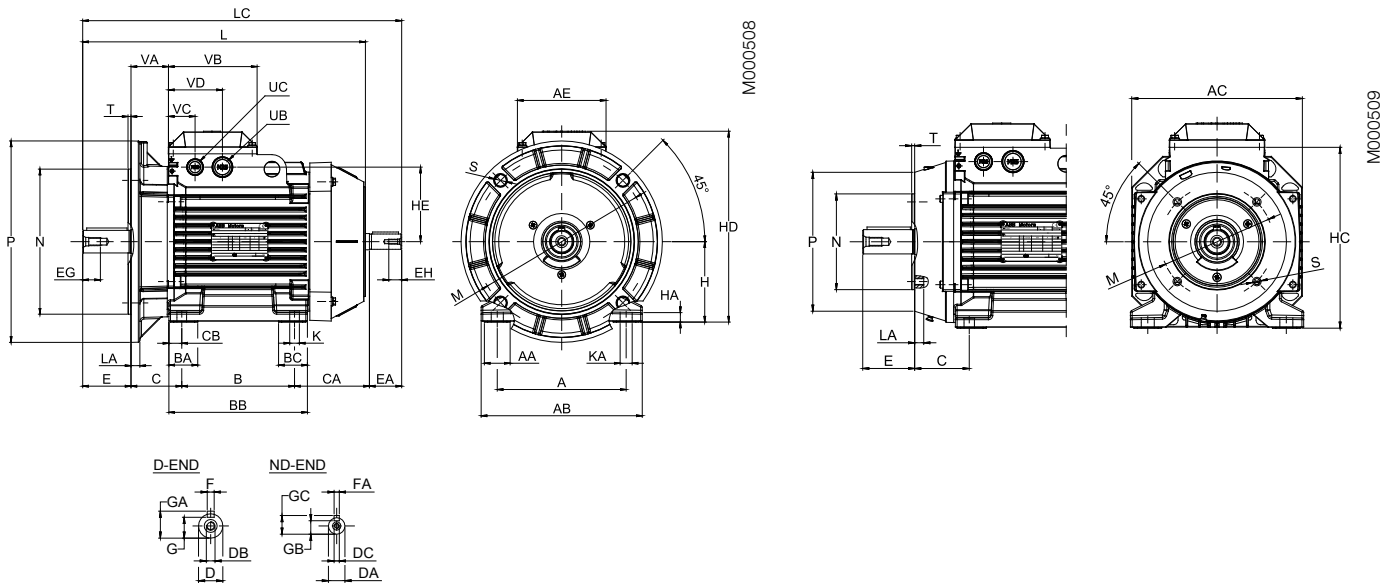

IM B35 (IM 2001), IM 2002; IM B34 (IM2101), IM 2102

Motor size	A	AA	AB	AC	AE	B	BA	BB	BC	C	CA	CB	D	DA	DB	DC	E	EA	EG	EH	F	FA
63	100	25	120	120	85	80	32	98	32	40	74	10	11	11	M4	M4	23	23	10	10	4	4
71	112	23	136	130	97	90	24.5	110	24.5	45	79.5	10	14	11	M5	M4	30	23	12.5	10	5	4
80	125	27	154	150	97	100	32	125	32	50	80.5	12.5	19	14	M6	M5	40	30	16	12.5	6	5
90S	140	27	170	177	110	100	32	125	32	56	83.5	12.5	24	14	M8	M5	50	30	19	12.5	8	5
90L	140	27	170	177	110	125	32	150	32	56	83.5	12.5	24	14	M8	M5	50	30	19	12.5	8	5
90 LD	140	27	170	177	110	125	32	150	32	56	105.5	12.5	24	14	M8	M5	50	30	19	12.5	8	5
100	160	32	200	197	110	140	36	172	36	63	93	16	28	19	M10	M6	60	40	22	16	8	6
112	190	32	230	197	110	140	36	172	36	70	136	16	28	19	M10	M6	60	40	22	16	8	6

Motor size	G	GA	GB	GC	H	HA	HC	HD	HE	K	KA	L	LC	UB	UC	VA	VB	VC	VD
63	8.5	12.5	8.5	12.5	63	7	120	151	50	7	11	214	237	pg11	M16x1.5	31	92	30.5	61.5
71	11	16	8.5	12.5	71	9	151	180	63.5	7	11	240	267	M20	M20	35			
80	15.5	21.5	11	16	80	10	164.5	193.5	68	10	10	265.5	300.5	M20	M20	37.5	97	30.5	66.5
90S	20	27	11	16	90	10	189	217	82.5	10	14	284.5	319.5	M25	M20	43.5	110	33	67
90L	20	27	11	16	90	10	189	217	82.5	10	14	309.5	344.5	M25	M20	43.5	110	33	67
90 LD	20	27	11	16	90	10	189	217	82.5	10	14	331.5	366.5	M25	M20	43.5	110	33	67
100	24	31	15.5	21.5	100	12	209	237	92.5	12	15	351	396	M25	M20	46.5	110	33	67
112	24	31	15.5	21.5	112	12	221	249	92.5	12	15	393	436	M25	M20	46.5	110	33	67

IM B35 (IM2001), IM 2002

Motor size	HB	LA	M	N	P	S	T
63	103	10	100	80	120	7	3
71	109	9.5	130	130	160	10	3.5
80	113.5	10	165	130	200	12	3.5
90S	127	10	165	130	200	12	3.5
90L	127	10	165	130	200	12	3.5
90 LD	127	10	165	130	200	12	3.5
100	137	11	215	180	250	15	4
112	137	11	215	180	250	15	4

IM B34 (IM 2101), IM 2102

Motor size	HB	LA	M	N	P	S	T
63	103	10	65	50	80	M5	2.5
71	109	11	85	70	105	M6	3
80	113.5	11	100	80	120	M6	3
90S	127	13	115	95	140	M8	3
90L	127	13	115	95	140	M8	3
90 LD	127	13	115	95	140	M8	3
100	137	14	130	110	160	M8	3.5
112	137	14	130	110	160	M8	3.5

Tolerances:

A, B	±0.8	H	+0 -0.5
D, DA	ISO j6	N	ISO j6
F, FA	ISO h9	C, CA	±0.8

Above table gives the main dimensions in mm.  
For detailed drawings please see our web-pages '[www.abb.com/motors&generators](http://www.abb.com/motors&generators)' or contact ABB.

# Industrial performance aluminum motors M3AA 71 - 132

## Dimension drawings

### Special design with two-piece flanges

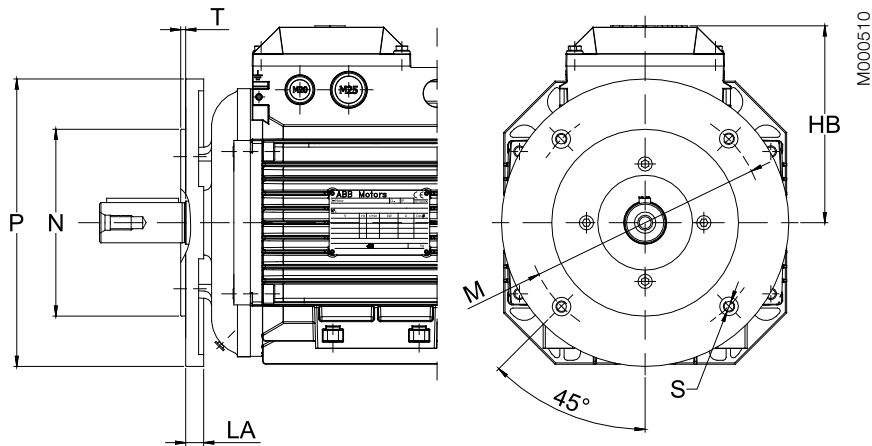

Motor size	IEC flange	Flange dimensions							Variant code	
		HB	P	M	N	LA	S	T	FF	FT
71	FT85	105	105	85	70	7.5	M6	2.5	-	218
	FF100/FT100	105	120	100	80	7.5	M6	3	220	219
	FF115/FT115	105	140	115	95	9.5	M8	3	223	224
	FF130/FT130	105	160	130	110	9.5	M8	3.5	226	227
	FF165/FT165	105	200	165	130	10.5	M10	3.5	233	234
80	FT85	110	105	85	70	7.5	M6	2.5	-	218
	FF100/FT100	110	120	100	80	7.5	M6	3	220	219
	FF115/FT115	110	140	115	95	9.5	M8	3	223	224
	FF130/FT130	110	160	130	110	9.5	M8	3.5	226	227
	FF165/FT165	110	200	165	130	10.5	M10	3.5	233	234
90	FT85	127	105	85	70	7.5	M6	2.5	-	218
	FF100/FT100	127	120	100	80	7.5	M6	3	220	219
	FF115/FT115	127	140	115	95	9.5	M8	3	223	224
	FF130/FT130	127	160	130	110	9.5	M8	3.5	226	227
	FF165/FT165	127	200	165	130	10.5	M10	3.5	233	234
100	FF130/FT130	137	160	130	110	9.5	M8	3.5	226	227
	FF165/FT165	137	200	165	130	10.5	M10	3.5	233	234
	FF215/FT215	137	250	215	180	12.5	M12	4	243	244
112	FF130/FT130	137	160	130	110	9.5	M8	3.5	226	227
	FF165/FT165	137	200	165	130	10.5	M10	3.5	233	234
	FF215/FT215	137	250	215	180	12.5	M12	4	243	244
132	FF215/FT215	164	250	215	180	12.5	M12	4	243	244
	FF265/FT265	164	300	265	230	16	M12	4	253	254

<sup>1)</sup> Variant code 200 'Flange ring holder' must be added when using the variant codes mentioned below.

<sup>2)</sup> Flanges with clearance (FF) or tapped (FT) holes for indicated screws.

Tolerances:

N ISO j6

Above table gives the main dimensions in mm.  
For detailed drawings please see our web-pages '[www.abb.com/motors&generators](http://www.abb.com/motors&generators)' or contact ABB.

# Industrial performance aluminum motors M3AA 132

## Dimension drawings

Foot-mounted motor; IM B 3 (IM 1001), IM 1002

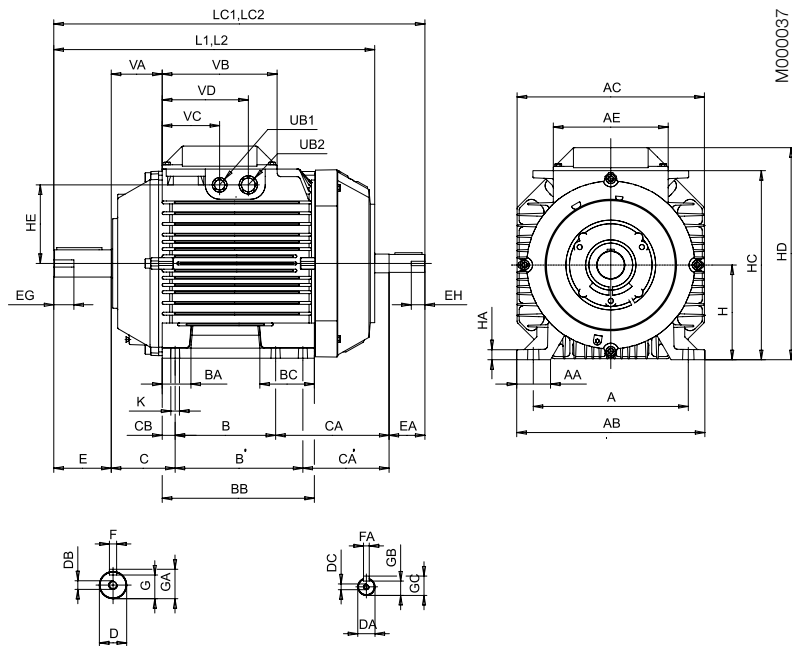

Flange-mounted motor, large flange;  
IM B 5 (IM 3001), IM 3002

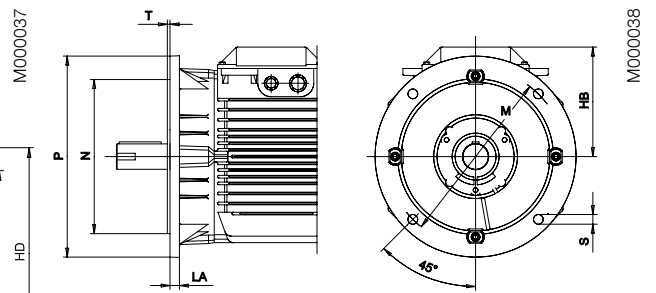

Flange-mounted motor, small flange;  
IM B 14 (IM 3601), IM 3602

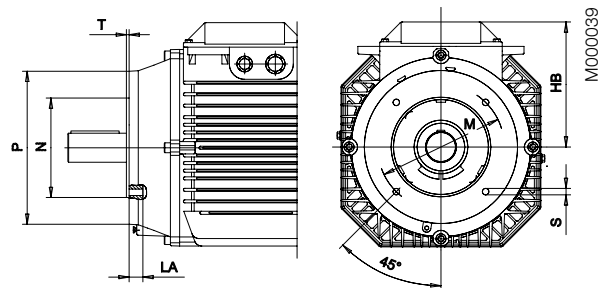

### IM B3 (IM 1001), IM 1002

Motor size	A	AA	AB	AC	AE	B	B'	BA	BB	BC	C	CA	CA'	CB	D	DA	DB	DC	E	EA	EG	EH	F	FA
132 <sup>1)</sup>	216	47	262	261	160	140	178	40	212	76	89	158	120	18	38	24	M12	M8	80	50	28	19	10	8
132 <sup>2)</sup>	216	47	262	261	160	140	178	40	212	76	89	261	223	18	38	24	M12	M8	80	50	28	19	10	8

Motor size	G	GA	GB	GC	H	HA	HC	HD	HE	HF	K	KA	L	LC	UB	UC	UD	VA	VB	VC	VD	VE
132 <sup>1)</sup>	33	41	20	27	132	14	263.5	295.5	109.5		12	15	447	517	M20	M25		71	160	80	120	
132 <sup>2)</sup>	33	41	20	27	132	14	287	321	123.5	143.5	12	15	550	620	M40	M32	M12	71	160	42	102	136

### IM B5 (IM3001), IM 3002

Motor size	HB	LA	M	N	P	S	T
132 <sup>1)</sup>	163.5	14	265	230	300	14.5	4
132 <sup>2)</sup>	189	14	265	230	300	14.5	4

### IM B14 (IM 3601), IM 3602

Motor size	HB	LA	M	N	P	S	T
132 <sup>1)</sup>	163.5	14.5	165	130	200	M10	3.5
132 <sup>2)</sup>	189	14.5	165	130	200	M10	3.5

Tolerances:

A, B	ISO js14
C, CA	+2 -2
D	ISO k6
DA	ISO j6
F, FA	ISO h9
H	+0 -0.5
N	ISO j6

<sup>1)</sup> all typex except <sup>2)</sup> SM<sub>-</sub>

Above table gives the main dimensions in mm. For detailed drawings please see our web-pages 'www.abb.com/motors&generators' or contact ABB.

# Industrial performance aluminum motors

## Dimension drawings

# M3AA 132

Foot- and flange-mounted motor; IM B 35 ( IM 2001), IM 2002, large flange

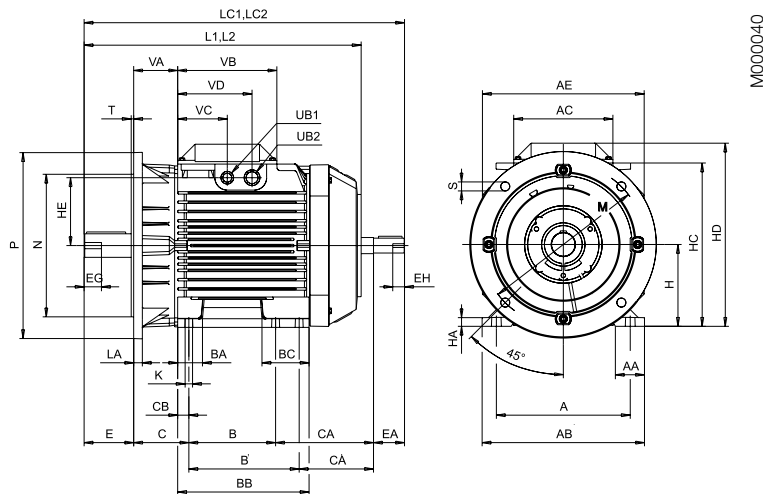

Foot- and flange-mounted motor; IM B 34 (IM 2101), IM 2102, small flange

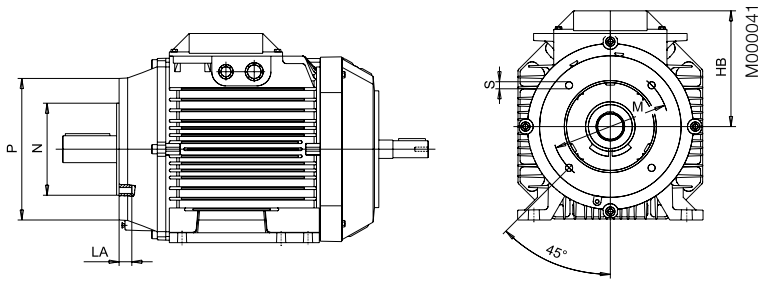

### IM B3 (IM 2001), IM 2002

Motor size	A	AA	AB	AC	AE	B	B'	BA	BB	BC	C	CA	CA'	CB	D	DA	DB	DC	E	EA	EG	EH	F	FA
132 <sup>1)</sup>	216	47	262	261	160	140	178	40	212	76	89	158	120	18	38	24	M12	M8	80	50	28	19	10	8
132 <sup>2)</sup>	216	47	262	261	160	140	178	40	212	76	89	261	223	18	38	24	M12	M8	80	50	28	19	10	8

Motor size	G	GA	GB	GC	H	HA	HC	HD	HE	HF	K	KA	L	LC	UB	UC	UD	VA	VB	VC	VD	VE
132 <sup>1)</sup>	33	41	20	27	132	14	263.5	295.5	109.5		12	15	447	517	M20	M25		71	160	80	120	
132 <sup>2)</sup>	33	41	20	27	132	14	287	321	123.5	143.5	12	15	550	620	M40	M32	M12	71	160	42	102	136

### IM B35 (IM 2001)

Motor size	HB	LA	M	N	P	S	T
132 <sup>1)</sup>	163,5	14	265	230	300	14,5	4
132 <sup>2)</sup>	189	14	265	230	300	14,5	4

### IM B34 (IM 2101)

Motor size	HB	LA	M	N	P	S	T
132 <sup>1)</sup>	163,5	14,5	165	130	200	M10	3,5
132 <sup>2)</sup>	189	14,5	165	130	200	M10	3,5

<sup>1)</sup> all typex except <sup>2)</sup> SM\_

Tolerances:

A, B	ISO js14
C, CA	+2 -2
D	ISO k6
DA	ISO j6
F, FA	ISO h9
H	+0 -0.5
N	ISO j6

Above table gives the main dimensions in mm. For detailed drawings please see our web-pages 'www.abb.com/motors&generators' or contact ABB.

# Industrial performance aluminum motors M3AA 160 - 180

## Dimension drawings

Foot-mounted motor; IM B3 (IM 1001), IM 1002

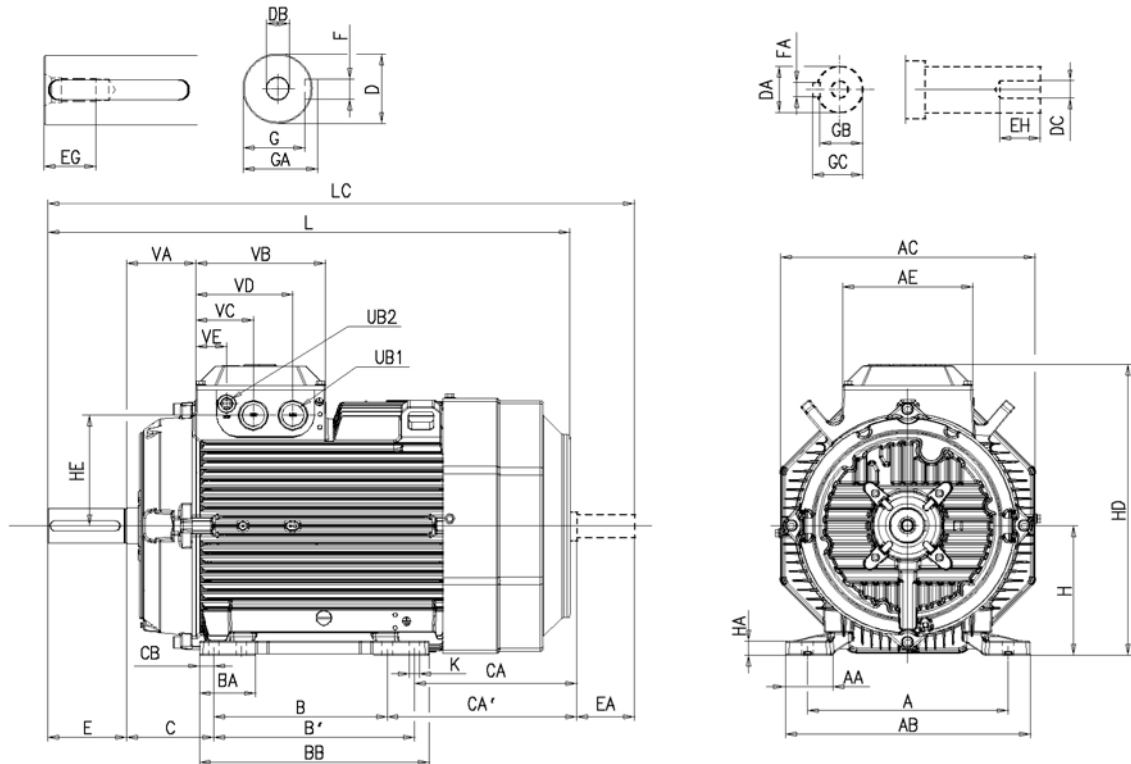

M000514

### IM B3 (IM 1001), IM 1002

Motor size	A	AA	AB	AC	AE	B	B'	BA	BB	C	CA	CA'	CB	D	DA	DB	DC	E	EA	EG	EH	F
160 <sup>2)</sup>	254	54	310	323	180	210	254	84	294	108	172	128	20	42	32	M16	M12	110	80	36	28	12
160 <sup>3)</sup>	254	54	310	323	180	210	254	84	294	108	269	225	20	42	32	M16	M12	110	80	36	28	12
180	279	68	341	354	180	241	279	78	319	121	263	225	20	48	32	M16	M12	110	80	36	28	14

Motor size	FA	G	GA	GB	GC	H	HA	HC	HD	HE	K	L	LC	UB1 <sup>1)</sup>	UB2 <sup>1)</sup>	VA	VB	VC	VD	VE
160 <sup>2)</sup>	10	37	45	27	35	160	20	342	370	139	15	584	680	2*M40	M16	88.5	180	80	135.5	43
160 <sup>3)</sup>	10	37	45	27	35	160	20	342	370	139	15	681	777	2*M40	M16	88.5	180	80	135.5	43
180	10	42.5	51.5	27	35	180	20	369	405	154	15	726	815	2*M40	M16	88.5	180	80	135.5	43

Tolerances:

A, B	ISO js14
C, CA	± 0.8
D, DA	ISO k6
F, FA	ISO h9
H	+0 -0.5

<sup>1)</sup> Knockout openings.

<sup>2)</sup> MLA-2 and MLB-2; MLA-4 poles; MLA-6 poles; MLA-8 and MLB-8 poles.

<sup>3)</sup> Remaining variants, i.e. MLC-2, MLD-2 and MLE-2 poles; MLB-4, MLC-4 and MLD-4 poles; MLC-8 poles.

Above table gives the main dimensions in mm. For detailed drawings please see our web-pages 'www.abb.com/motors&generators' or contact ABB.



# Industrial performance aluminum motors M3AA 160 - 180

## Dimension drawings

Flange-mounted motor; IM B5 (IM 3001), IM 3002

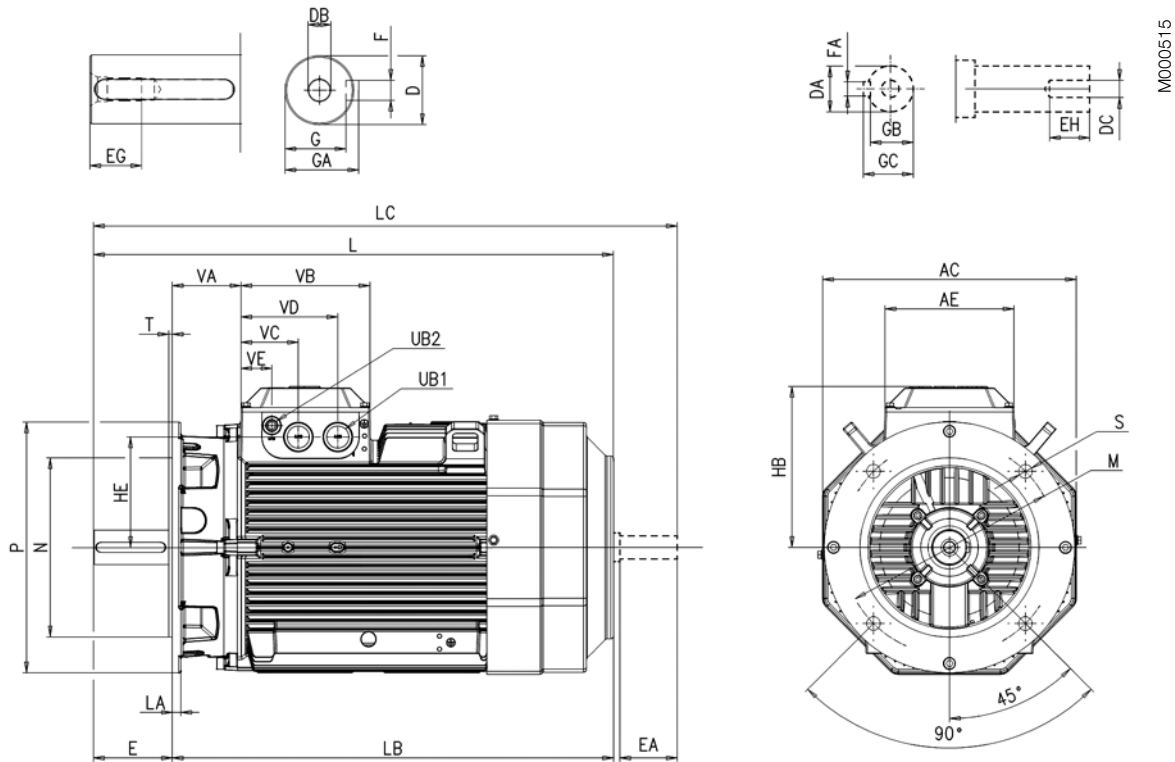

M000515

### IM B5 (IM 3001), IM 3002

Motor size	AC	AE	D	DA	DB	DC	E <sup>4)</sup>	EA	EG	EH	F	FA	G	GA	GB	GC	HB	HE
160 <sup>2)</sup>	323	180	42	32	M16	M12	110	80	36	28	12	10	37	45	27	35	210	139
160 <sup>3)</sup>	323	180	42	32	M16	M12	110	80	36	28	12	10	37	45	27	35	210	139
180	354	180	48	32	M16	M12	110	80	36	28	14	10	42.5	51.5	27	35	225	154

Motor size	L	LA	LB	LC	M	N	P	S	T	UB1 <sup>1)</sup>	UB2 <sup>1)</sup>	VA	VB	VC	VD	VE
160 <sup>2)</sup>	584	20	474	680	300	250	350	19	5	2*M40	M16	88.5	180	43	80	135.5
160 <sup>3)</sup>	681	20	571	777	300	250	350	19	5	2*M40	M16	88.5	180	43	80	135.5
180	726	15	616	815	300	250	350	19	5	2*M40	M16	88.5	180	43	80	135.5

Tolerances:

D, DA	ISO k6
F, FA	ISO h9
N	ISO j6

<sup>1)</sup> Knockout openings.

<sup>2)</sup> MLA-2 and MLB-2; MLA-4 poles; MLA-6 poles; MLA-8 and MLB-8 poles.

<sup>3)</sup> Remaining variants, i.e. MLC-2, MLD-2 and MLE-2 poles; MLB-4, MLC-4 and MLD-4 poles; MLC-8 poles.

<sup>4)</sup> Shoulder of shaft extension and contact surface of flange are in same plane.

Above table gives the main dimensions in mm. For detailed drawings please see our web-pages 'www.abb.com/motors&generators' or contact ABB.

# Industrial performance aluminum motors M3AA 160 - 180

## Dimension drawings

Foot- and flange-mounted motor; IM B35 (IM 2001), IM 2002

M000516

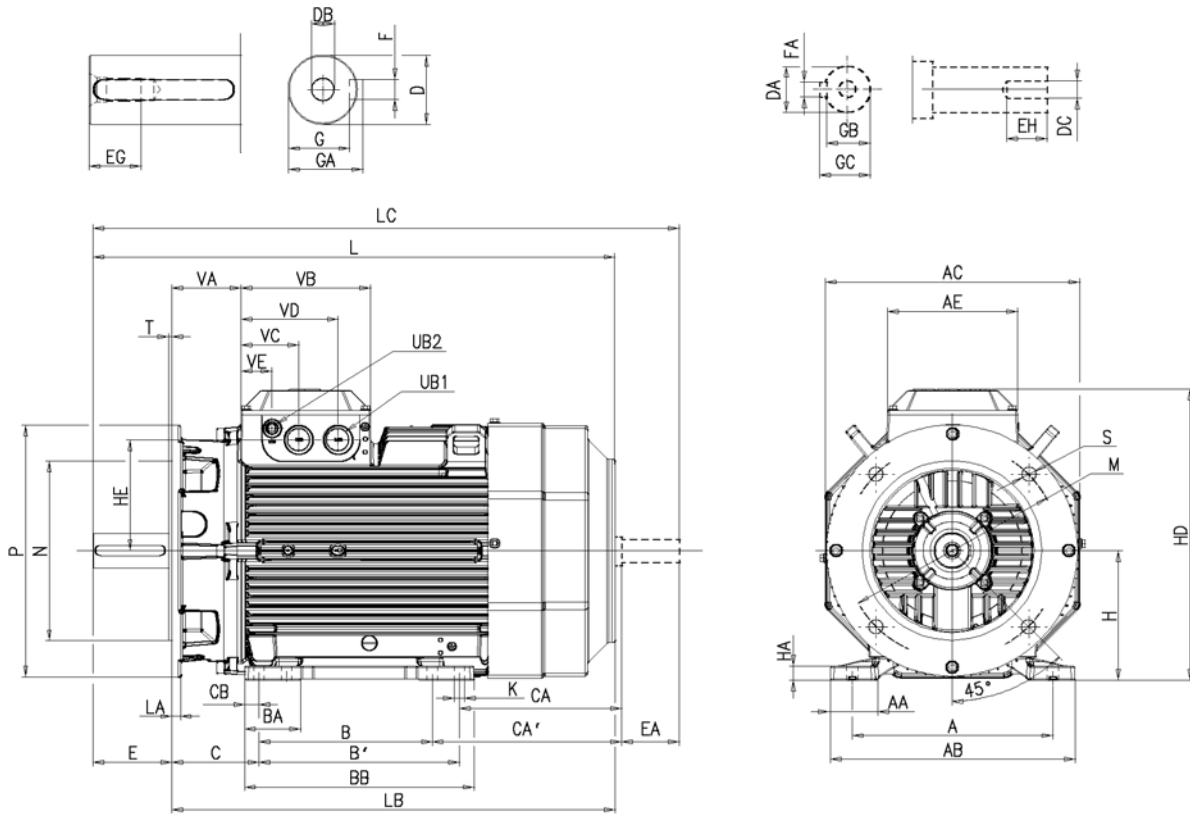

### IM B35 (IM 2001), IM 2002

Motor size	A	AA	AB	AC	AE	B	B'	BA	BB	C	CA	CA'	CB	D	DA	DB	DC
160 2)	254	54	310	323	180	210	254	84	294	108	172	128	20	42	32	M16	M12
160 3)	254	54	310	323	180	210	254	84	294	108	269	225	20	42	32	M16	M12
180	279	68	341	354	180	241	279	78	319	121	263	225	20	48	32	M16	M12

Motor size	E <sup>4)</sup>	EA	EG	EH	F	FA	G	GA	GB	GC	H	HA	HC	HD	HE	K	L
160 2)	110	80	36	28	12	10	37	45	27	35	160	20	342	370	139	14.5	584
160 3)	110	80	36	28	12	10	37	45	27	35	160	20	342	370	139	14.5	681
180	110	80	36	28	14	10	42.5	51.5	27	35	180	20	369	405	154	14.5	726

Motor size	LA	LB	LC	M	N	P	S	T	UB1 <sup>1)</sup>	UB2 <sup>1)</sup>	VA	VB	VC	VD	VE
160 2)	20	474	680	300	250	350	19	5	2*M40	M16	88.5	180	80	135.5	43
160 3)	20	571	777	300	250	350	19	5	2*M40	M16	88.5	180	80	135.5	43
180	15	616	815	300	250	350	19	5	2*M40	M16	88.5	180	80	135.5	43

Tolerances:

A, B	ISO js14
C, CA	±8
D, DA	ISO k6
F, FA	ISO h9
H	+0 - 0.5
N	ISO j6

<sup>1)</sup> Knockout openings.

<sup>2)</sup> MLA-2 and MLB-2; MLA-4 poles; MLA-6 poles; MLA-8 and MLB-8 poles.

<sup>3)</sup> Remaining variants, i.e. MLC-2, MLD-2 and MLE-2 poles; MLB-4, MLC-4 and MLD-4 poles; MLC-8 poles.

<sup>4)</sup> Shoulder of shaft extension and contact surface of flange are in same plane.

Above table gives the main dimensions in mm. For detailed drawings please see our web-pages 'www.abb.com/motors&generators' or contact ABB.

# Industrial performance aluminum motors

## Dimension drawings

# M3AA 200 - 225

Foot-mounted motor; IM B3 (IM 1001), IM 1002

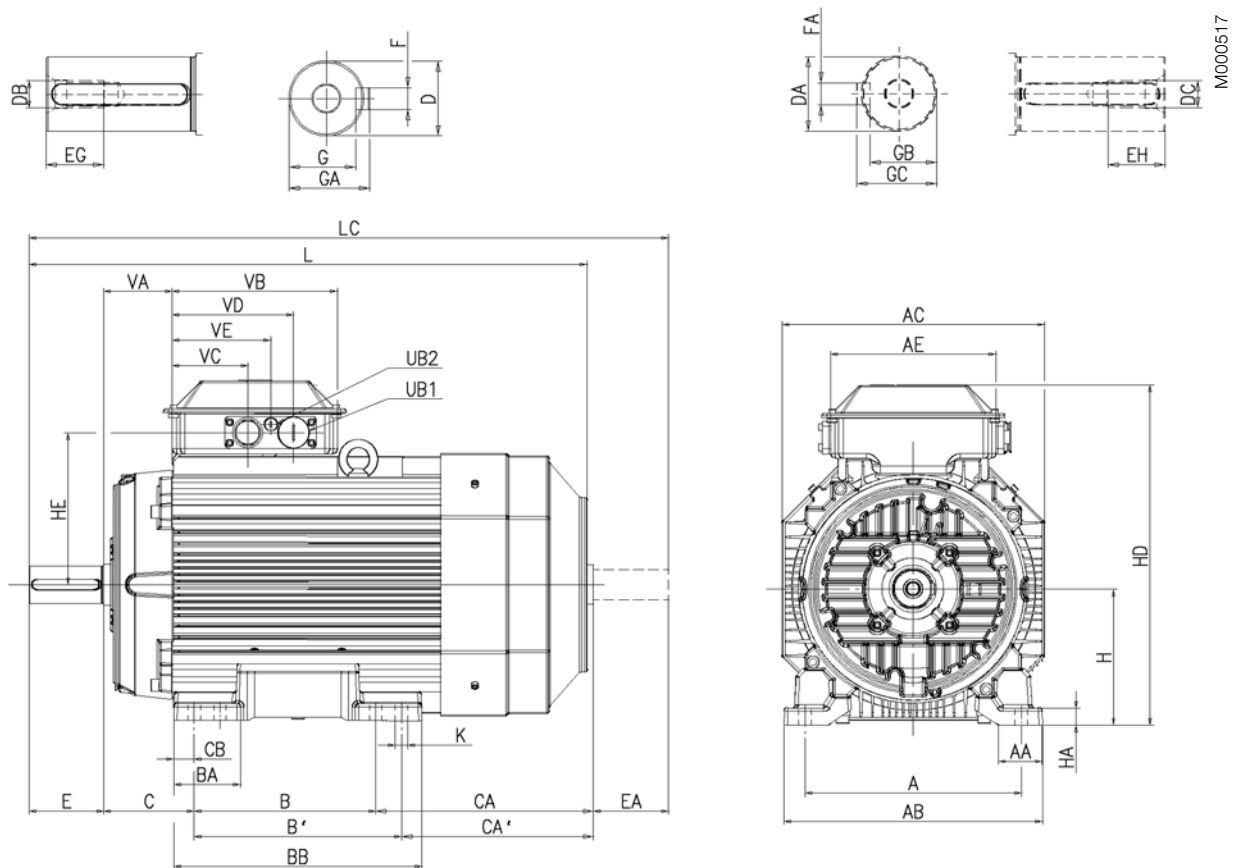

### IM B3 (IM 1001), IM 1002

Motor size	A	AA	AB	AC	AE	B	B'	BA	BB	C	CA	CA'	CB	D	DA	DB	DC	E	EA	EG	EH	F	FA
200	318	64	380	386	243	267	305	112	365	133	314	276	30	55	45	M20	M16	110	110	42	36	16	14
225-2 p	356	69	418	425	243	286	311	102	365	149	314	289	24.5	55	55	M20	M20	110	110	42	42	16	14
225 4-8 p	356	69	418	425	243	286	311	102	365	149	314	289	24.5	60	55	M20	M20	140	110	42	42	18	16

Motor size	G	GA	GB	GC	H	HA	HD <sup>2)</sup>	HD <sup>3)</sup>	HE <sup>2)</sup>	HE <sup>3)</sup>	K	L	LC	UB <sup>1)</sup>	VA	VB	VC <sup>2)</sup>	VC <sup>3)</sup>	VD <sup>2)</sup>	VD <sup>3)</sup>	VE <sup>2)</sup>	VE <sup>2)</sup>
200	49	59	39.5	48.5	200	25	500	532	224	239	18	821	934	2xFL13	101	243	112	77	179	167	145	122
225-2 p	49	59	49	59	225	25	547	579	244.5	260	18	850	971	2xFL13	93.5	243	112	77	179	167	145	122
225 4-8 p	53	64	49	59	225	25	547	579	244.5	260	18	880	1001	2xFL13	93.5	243	112	77	179	167	145	122

Tolerances:

A, B	ISO js14
C, CA	± 0.8
D 55-65	ISO m6
DA 45-55	ISO k6
F, FA	ISO h9
H	+0 -0.5

<sup>1)</sup> Flange opening is provided with pipe flange FL 13, with tapped lead-in holes plugged with sealing plugs.

Single- and two-speed motors: 2 x M40 + M16.

Motors for 230VD 50Hz or 225 SMC-2, 225 SMD-2, 225 SMD-4 have pipe flange FL21 and 2 x M63 + M16

<sup>2)</sup> For flange opening FL13: 2 x M40 + M16

<sup>3)</sup> For extra large flange opening FL21: 2 x M63 + M16

Above table gives the main dimensions in mm.  
For detailed drawings please see our web-pages '[www.abb.com/motors&generators](http://www.abb.com/motors&generators)' or contact ABB.

# Industrial performance aluminum motors M3AA 200 - 225

## Dimension drawings

Flange-mounted motor; IM B5 (IM 3001), IM 3002

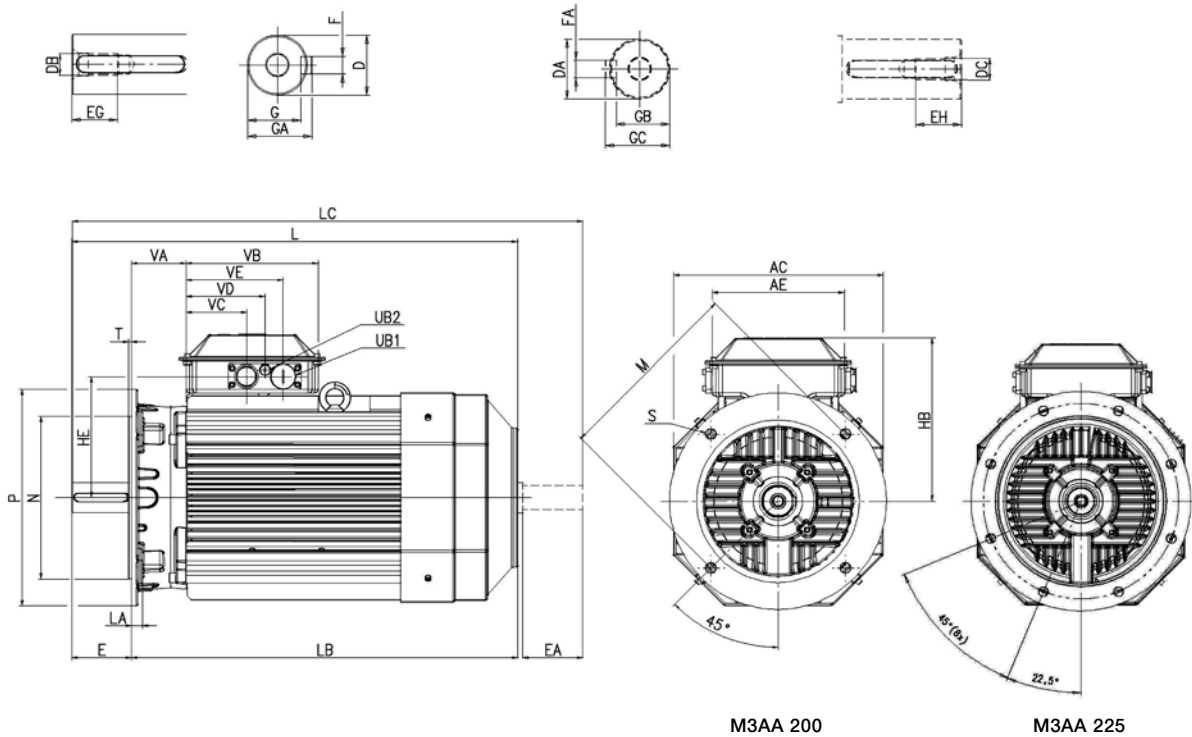

### IM B5 (IM 3001), IM 3002

Motor size	AC	AE	D	DA	DB	DC	E <sup>1)</sup>	EA	EG	EH	F	FA	G	GA	GB	GC	HB <sup>3)</sup>	HB <sup>4)</sup>	HE <sup>3)</sup>	HE <sup>4)</sup>
200	386	243	55	45	M20	M16	110	110	42	36	14	16	49	59	39.5	48.5	300	332	224	239
225-2 p	425	243	55	55	M20	M20	110	110	42	42	16	16	49	59	49	59	300	332	244	260
225 4-8 p	425	243	60	55	M20	M20	140	110	42	42	16	16	53	64	49	59	322	354	244	260

Motor size	L	LA	LB	LC	M	N	P	S	T	UB <sup>2)</sup>	VA	VB	VC <sup>3)</sup>	VC <sup>4)</sup>	VD <sup>3)</sup>	VD <sup>4)</sup>	VE <sup>3)</sup>	VE <sup>4)</sup>
200	821	20	711	934	350	300	400	19	5	2xFL13	101	243	112	77	179	167	145	122
225-2 p	850	22	740	971	400	350	450	19	5	2xFL13	93.5	243	112	77	179	167	145	122
225 4-8 p	880	22	740	1001	400	350	450	19	5	2xFL13	93.5	243	112	77	179	167	145	122

Tolerances:

<b>D 55-65</b>	ISO m6
<b>DA 45-55</b>	ISO k6
<b>F, FA</b>	ISO h9
<b>N</b>	ISO j6

<sup>1)</sup> Shoulder of shaft extension and contact surface of flange are in the same plane.

<sup>2)</sup> Flange opening is provided with pipe flange FL 13, with tapped lead-in holes plugged with sealing plugs. Single- and two-speed motors: 2 x M40 + M16.

Motors for 230VD 50Hz or 225 SMC-2, 225 SMD-2, 225 SMD-4 have pipe flange FL21 and 2 x M63 + M16

<sup>3)</sup> For flange opening FL13: 2 x M40 + M16

<sup>4)</sup> For extra large flange opening FL21: 2 x M63 + M16

Above table gives the main dimensions in mm. For detailed drawings please see our web-pages 'www.abb.com/motors&generators' or contact ABB.

# Industrial performance aluminum motors M3AA 200 - 225

## Dimension drawings

Foot- and flange-mounted motor; IM B35 (IM 2001), IM 2002

M000519

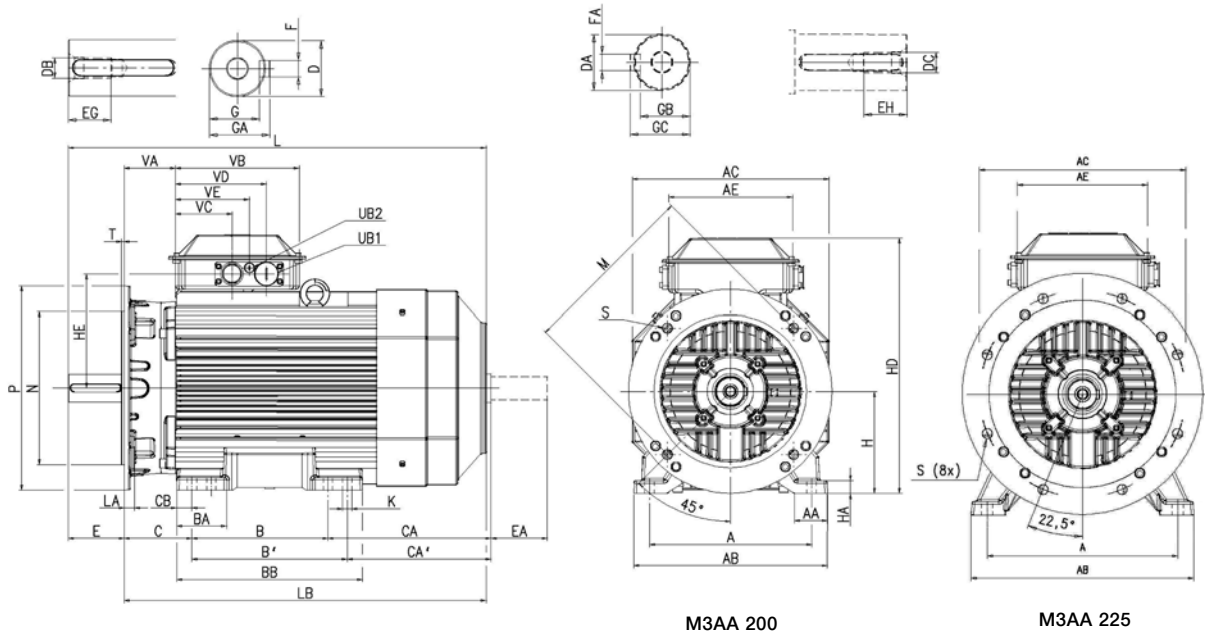

### IM B35 (IM 2001), IM 2002

Motor size	A	AA	AB	AC	AE	B	B'	BA	BB	C	CA	CA'	CB	D	DA	DB	DC	E <sup>1)</sup>	EA	EG	EH	F	FA	G	GA	GB	GC
200	318	64	380	386	243	267	305	112	365	133	314	276	30	55	45	M20	M16	110	110	42	36	16	14	49	59	39.5	48.5
225-2 p	356	69	418	425	243	286	311	102	365	149	314	289	24.5	55	55	M20	M20	110	110	42	42	16	14	49	59	49	59
225 4-8 p	356	69	418	425	243	286	311	102	365	149	314	289	24.5	60	55	M20	M20	140	110	42	42	18	16	53	64	49	59

Motor size	H	HA	HD <sup>3)</sup>	HD <sup>4)</sup>	HE <sup>3)</sup>	HE <sup>4)</sup>	K	L	LA	LB	LC	M	N	P	S	T	UB <sup>2)</sup>	VA	VB	VC <sup>3)</sup>	VC <sup>4)</sup>	VD <sup>3)</sup>	VD <sup>4)</sup>	VE <sup>3)</sup>	VE <sup>4)</sup>
200	200	25	500	532	223	239	18	821	20	711	934	350	300	400	19	5	2xFL13	101	243	112	77	179	167	145	122
225-2 p	225	25	547	579	244	260	18	850	22	740	971	400	350	450	19	5	2xFL13	93.5	243	112	77	179	167	145	122
225 4-8 p	225	25	547	579	244	260	18	880	22	740	1001	400	350	450	19	5	2xFL13	93.5	243	112	77	179	167	145	122

#### Tolerances:

A, B	ISO js14
C, CA	± 0.8
D 55-75	ISO m6
DA 45-55	ISO k6
F, FA	ISO h9
H	+0 -0.5
N	ISO j6

- <sup>1)</sup> Shoulder of shaft extension and contact surface of flange are in the same plane.
- <sup>2)</sup> Flange opening is provided with pipe flange FL 13, with tapped lead-in holes plugged with sealing plugs.  
Single- and two-speed motors: 2 x M40 + M16.  
Motors for 230VD 50Hz or 225 SMC-2, 225 SMD-2, 225 SMD-4 have pipe flange FL21 and 2 x M63 + M16
- <sup>3)</sup> For flange opening FL13: 2 x M40 + M16
- <sup>4)</sup> For extra large flange opening FL21: 2 x M63 + M16

Above table gives the main dimensions in mm.  
For detailed drawings please see our web-pages '[www.abb.com/motors&generators](http://www.abb.com/motors&generators)' or contact ABB.

# Industrial performance aluminum motors

## Dimension drawings

# M3AA 250 - 280

Foot-mounted motor; IM B3 (IM 1001), IM 1002

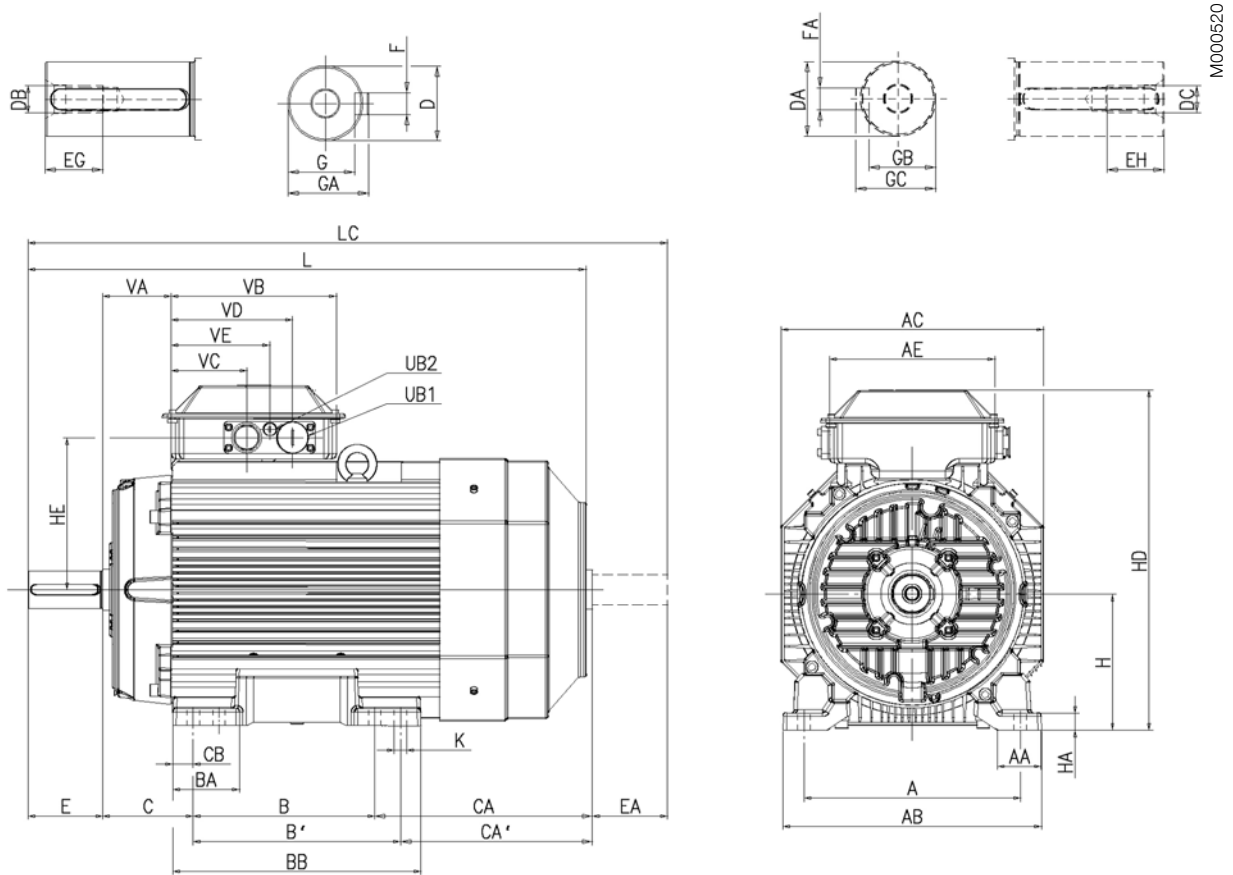

### IM B3 (IM 1001), IM 1002

Motor size	A	AA	AB	AC	AE	B	B'	BA	BB	C	CA	CA'	CB	D	DA	DB	DC	E	EA	EG	EH	F	FA
250 -2 p	406	78	473	471	243	311	349	106	409	168	281	243	40	60	55	M20	M20	140	110	42	42	18	16
250 4-8 p	406	78	473	471	243	311	349	106	409	168	281	243	30	65	55	M20	M20	140	110	42	42	18	16
280 -2 p	457	102.5	522	471	243	368	419	92	489	190	202	151	37.5	65	55	M20	M20	140	110	42	42	18	16
280 4-8 p	457	102.5	522	471	243	368	419	92	489	190	202	151	37.5	75	55	M20	M20	140	110	42	42	20	16

Motor size	G	GA	GB	GC	H	HA	HD <sup>2)</sup>	HD <sup>3)</sup>	HE <sup>2)</sup>	HE <sup>3)</sup>	K	L	LC	UB <sup>1)</sup>	VA	VB	VC <sup>3)</sup>	VC <sup>4)</sup>	VD <sup>3)</sup>	VD <sup>4)</sup>	VE <sup>3)</sup>	VE <sup>4)</sup>
250 -2 p	53	64	49	59	250	30	594	627	268	284	22	884	1010	2xFL13	93.5	243	112	77	179	167	145	122
250 4-8 p	58	69	49	59	250	30	594	627	268	284	22	884	1010	2xFL13	93.5	243	112	77	179	167	145	122
280 -2 p	58	69	49	59	280	40	-	657	-	284	24	884	1010	2xFL21	93.5	243	-	77	-	167	-	122
280 4-8 p	67.5	79.5	49	59	280	40	-	657	-	284	24	884	1010	2xFL21	93.5	243	-	77	-	167	-	122

#### Tolerances:

A, B	ISO js14
C, CA	± 0.8
D 55-75	ISO m6
DA 45-55	ISO k6
F, FA	ISO h9
H	+0 -0.5

- <sup>1)</sup> Flange opening is provided with pipe flange FL 13, with tapped lead-in holes plugged with sealing plugs. . Single- and two-speed motors: 2 x M40 + M16. Motors for 230VD 50Hz or 250 SMC-2, 250 SMC-4 and all 280 have pipe flange FL21 and 2 x M63 + M16
- <sup>2)</sup> For flange opening FL13: 2 x M40 + M16
- <sup>3)</sup> For extra large flange opening FL21: 2 x M63 + M16

Above table gives the main dimensions in mm. For detailed drawings please see our web-pages '[www.abb.com/motors&generators](http://www.abb.com/motors&generators)' or contact ABB.

# Industrial performance aluminum motors M3AA 250 - 280

## Dimension drawings

Flange-mounted motor; IM B5 (IM 3001), IM 3002

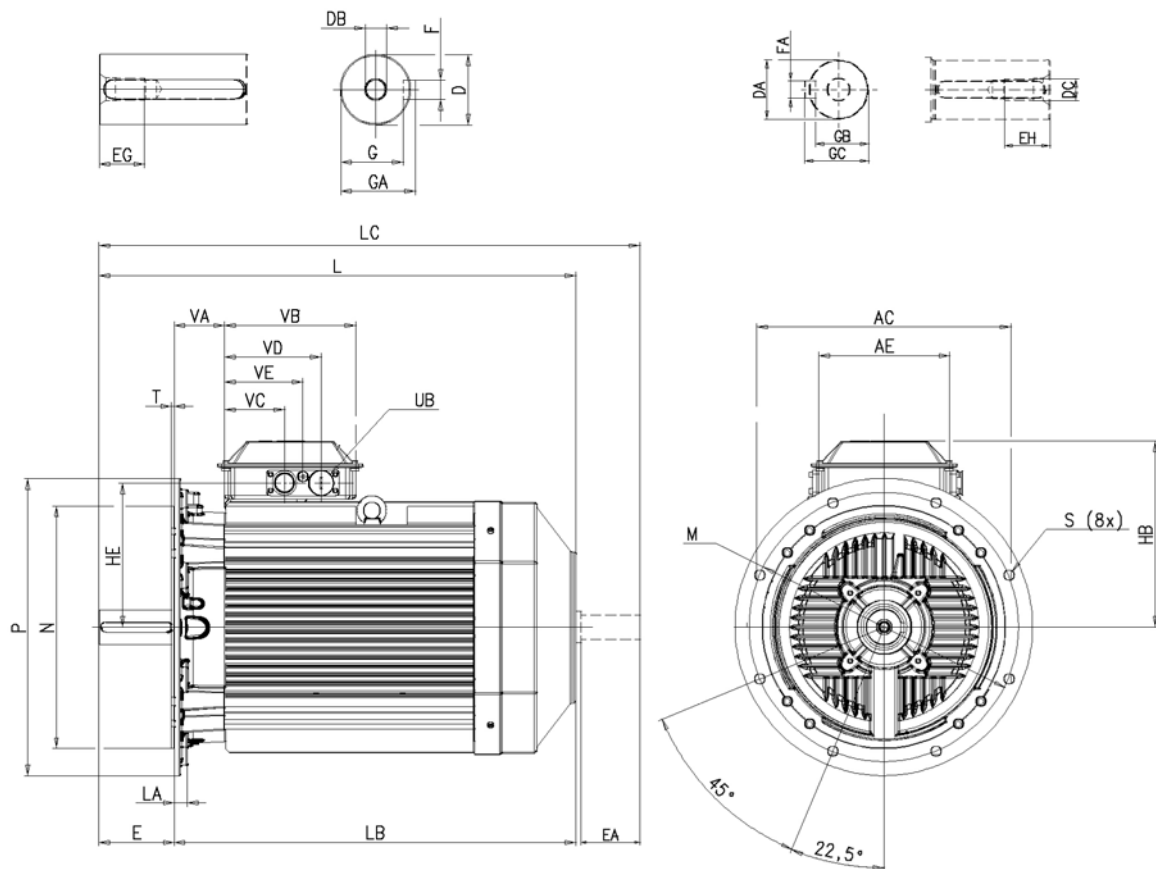

M000521

### IM B5 (IM 3001), IM 3002

Motor size	AC	AE	D	DA	DB	DC	E <sup>1)</sup>	EA	EG	EH	F	FA	G	GA	GB	GC	HB <sup>3)</sup>	HB <sup>4)</sup>	HE <sup>3)</sup>	HE <sup>4)</sup>
250 -2 p	471	243	60	55	M20	M20	140	110	42	42	18	16	53	64	49	59	344	377	268	284
250 4-8 p	471	243	65	55	M20	M20	140	110	42	42	18	16	58	69	49	59	344	377	268	284
280 -2 p	471	243	65	55	M20	M20	140	110	42	42	18	16	58	69	49	59	-	377	-	284
280 4-8 p	471	243	75	55	M20	M20	140	110	42	42	20	16	67.5	79.5	49	59	-	377	-	284

Motor size	L	LA	LB	LC	M	N	P	S	T	UB <sup>2)</sup>	VA	VB	VC <sup>3)</sup>	VC <sup>4)</sup>	VD <sup>3)</sup>	VD <sup>4)</sup>	VE <sup>3)</sup>	VE <sup>4)</sup>
250 -2 p	884	24	744	1010	500	450	550	19	5	2xFL13	93.5	243	112	77	179	167	145	122
250 4-8 p	884	24	744	1010	500	450	550	19	5	2xFL13	93.5	243	112	77	179	167	145	122
280 -2 p	884	24	744	1010	500	450	550	19	5	2xFL21	93.5	243	-	77	-	167	-	122
280 4-8 p	884	24	744	1010	500	450	550	19	5	2xFL21	93.5	243	-	77	-	167	-	122

Tolerances:

<b>D 55-75</b>	ISO m6
<b>DA 45-55</b>	ISO k6
<b>F, FA</b>	ISO h9
<b>N</b>	ISO j6

<sup>1)</sup> Shoulder of shaft extension and contact surface of flange are in the same plane.

<sup>2)</sup> Flange opening is provided with pipe flange FL 13, with tapped lead-in holes plugged with sealing plugs.  
Single- and two-speed motors: 2 x M40 + M16.

Motors for 230VD 50Hz or 250 SMC-2, 250 SMC-4 and all 280 have pipe flange FL21 and 2 x M63 + M16

<sup>3)</sup> For flange opening FL13: 2 x M40 + M16

<sup>4)</sup> For extra large flange opening FL21: 2 x M63 + M16

Above table gives the main dimensions in mm.  
For detailed drawings please see our web-pages '[www.abb.com/motors&generators](http://www.abb.com/motors&generators)' or contact ABB.

# Industrial performance aluminum motors M3AA 250 - 280

## Dimension drawings

Foot- and flange-mounted motor; IM B35 (IM 2001), IM 2002

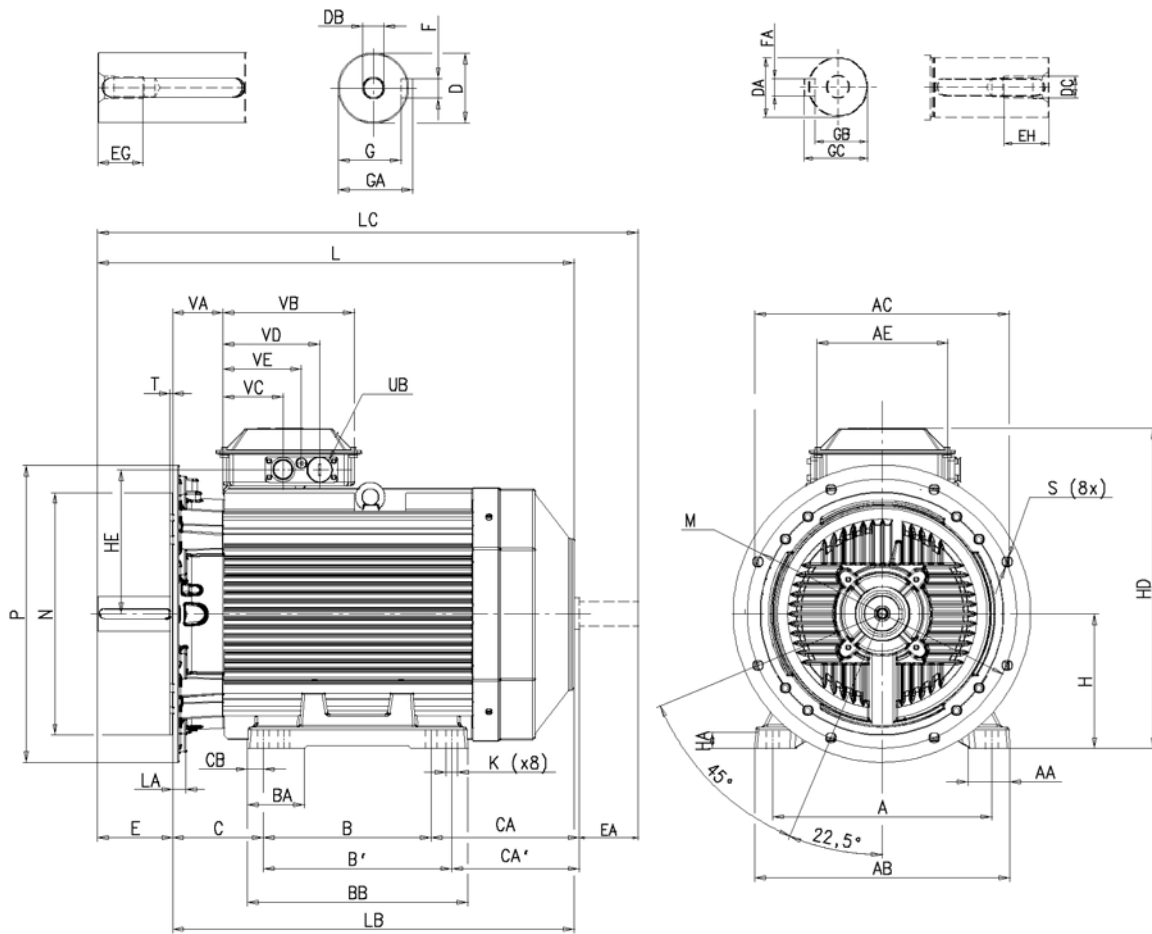

### IM B35 (IM 2001), IM 2002

Motor size	A	AA	AB	AC	AE	B	B'	BA	BB	C	CA	CA'	CB	D	DA	DB	DC	E <sup>1)</sup>	EA	EG	EH	F	FA	G	GA	GB	GC
250 -2 p	406	78	474	471	243	311	349	106	409	168	281	243	40	60	55	M20	M20	140	110	42	42	18	16	53	64	49	59
250 4-8 p	406	78	474	471	243	311	349	106	409	168	281	243	30	65	55	M20	M20	140	110	42	42	18	16	58	69	49	59
280 -2 p	457	103	525	471	243	368	419	92	489	190	202	151	38	65	55	M20	M20	140	110	42	42	18	16	58	69	49	59
280 4-8 p	457	103	525	471	243	368	419	92	489	190	202	151	38	75	55	M20	M20	140	110	42	42	20	16	68	80	49	59

Motor size	H	HA	HD <sup>3)</sup>	HD <sup>4)</sup>	HE <sup>3)</sup>	HE <sup>4)</sup>	K	L	LA	LB	LC	M	N	P	S	T	UB <sup>2)</sup>	VA	VB	VC <sup>3)</sup>	VC <sup>4)</sup> VD <sup>3)</sup>	VD <sup>4)</sup>	VE <sup>3)</sup>	VE <sup>4)</sup>	
250 -2 p	250	30	594	627	268	284	22	884	24	744	1010	500	450	550	19	5	2xFL13	93	243	112	77	179	167	145	122
250 4-8 p	250	30	594	627	268	284	22	884	24	744	1010	500	450	550	19	5	2xFL13	93	243	112	77	179	167	145	122
280 -2 p	280	40	-	657	-	284	24	884	24	744	1010	500	450	550	19	5	2xFL21	93	243	-	77	-	167	-	122
280 4-8 p	280	40	-	657	-	284	24	884	24	744	1010	500	450	550	19	5	2xFL21	93	243	-	77	-	167	-	122

Tolerances:

A, B	ISO js14
C, CA	± 0.8
D 55-75	ISO m6
DA 45-55	ISO k6
F, FA	ISO h9
H	+0 -0.5
N	ISO js6

<sup>1)</sup> Shoulder of shaft extension and contact surface of flange are in the same plane.

<sup>2)</sup> Flange opening is provided with pipe flange FL 13, with tapped lead-in holes plugged with sealing plugs.  
Single- and two-speed motors: 2 x M40 + M16.

<sup>3)</sup> For flange opening FL13: 2 x M40 + M16

<sup>4)</sup> For extra large flange opening FL21: 2 x M63 + M16

Above table gives the main dimensions in mm.  
For detailed drawings please see our web-pages '[www.abb.com/motors&generators](http://www.abb.com/motors&generators)' or contact ABB.



# Accessories

## Protective roof and variable speed drives

**Protective roof**  
Variant code 005

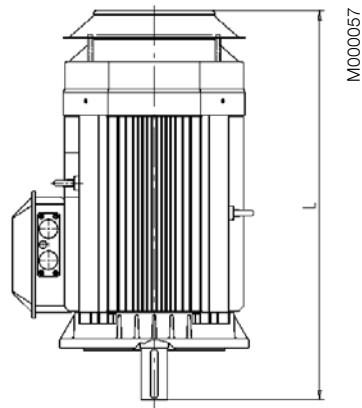

**Tacho**  
Variant codes; 472, 473, 572 and 573

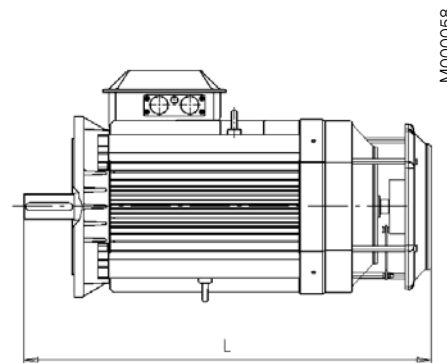

**Separate cooling with or without tacho**  
Variant codes; 183, 474, 476, 477, 189, 574, 576 and 577

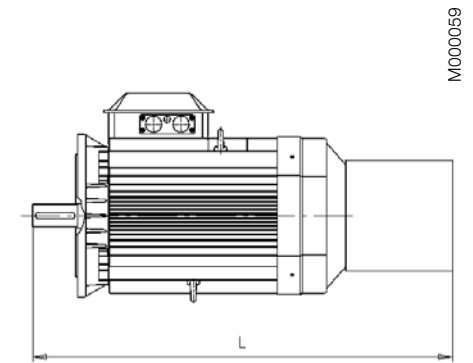

M3AA	Variant codes	183	189	472, 473 572, 573	474, 476 477, 574 576, 577
<b>Motor size</b>	<b>L</b>	<b>L</b>	<b>L</b>	<b>L</b>	<b>L</b>
63 to 132	1)	1)	1)	1)	1)
160 <sup>2)</sup>	635	996	851	668	996
160 <sup>3)</sup>	732	1093	948	765	1093
180	779	1143	998	811	1143
200	875	1274	1129	918	1274
225 <sup>4)</sup>	902	1307	1162	946	1307
225 <sup>5)</sup>	932	1337	1192	976	1337
250	937	1351	1206	982	1351
280	937	1351	1206	982	1351

<sup>1)</sup> On request.

<sup>2)</sup> MLA-2, MLB-2 and MLC-2 poles; MLA-4 poles; MLA-6 poles; MLA-8 and MLB-8 poles.

<sup>3)</sup> Remaining variants, i.e. MLD-2 and MLE-2 poles; MLB-4, MLC-4 and MLD-4 poles; MLC-8 poles.

<sup>4)</sup> 2-poles

<sup>5)</sup> 4-8 poles

# Slide rails for motor sizes 160 to 280

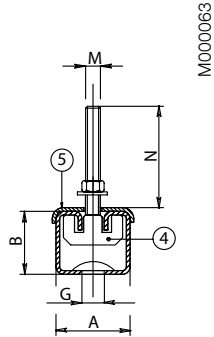
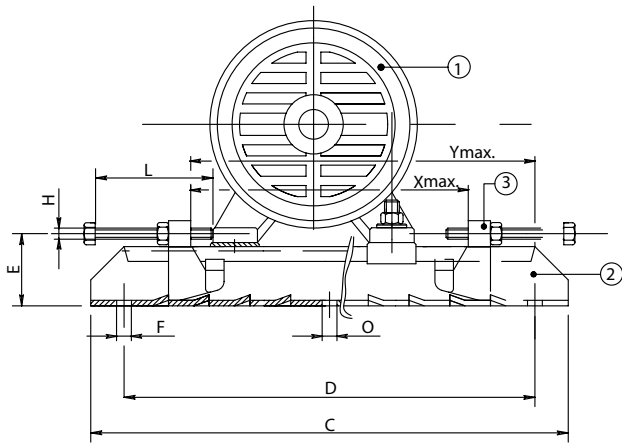

M0000063

- ① Motor
- ② Rail
- ③ Movable adjusting bolt
- ④ Fixing bolt, motor
- ⑤ Plate

Motor size	Type	Product code 3GZV103001-	A	B	C	D	E	F	G	H	L	M	N	O	Xmax	Ymax	weight kg
160-180	TT180/12	-14	75	42	700	630	57	17	26	M12	120	M12	50	-	520	580	12.0
200-225	TT225/16	-15	82	50	864	800	68	17	27	M16	140	M16	65	17	670	740	20.4
250-280	TT280/20	-16	116	70	1072	1000	90	20	27	M18	150	M20	80	20	870	940	43.0

1)

<sup>1)</sup> Smaller sizes on request.

Each set includes two complete slide rails including screw for mounting the motor on the rails. Screws for mounting the rails on the foundation are not included. Slide rails are supplied with unmachined lower surfaces and should, prior to tightening down, be supported in a suitable manner.

# Industrial performance aluminum motors in brief

Size	M3AA	63	71	80	90	100	112	132
<b>Stator and feet</b>	Material	Diecast aluminum alloy						
	Paint colour shade	Munsell blue 8B 4.5/3.25 / NCS 4822 B05G						
	Surface treatment	Polyester powder paint, $\geq 30\mu\text{m}$						
<b>Feet</b>		Fixed feet						
	Material	Aluminum alloy, integrated with stator.						
<b>Bearing end shields</b>	Material	Diecast aluminum alloy						
	Paint colour shade	Munsell blue 8B 4.5/3.25 / NCS 4822 B05G						
	Surface treatment	Polyester powder paint, $\geq 30\mu\text{m}$						
<b>Bearings</b>	D-end	6202-2Z/C3	6203-2Z/C3	6204-2Z/C3	6205-2Z/C3	6306-2Z/C3	6306-2Z/C3	6208-2Z/C3 <sup>1)</sup> 6308-2Z/C3 <sup>2)</sup>
	N-end	6201-2Z/C3	6202-2C/C3	6203-2Z/C3	6204-2Z/C3	6205-2Z/C3	6205-2Z/C3	6206-2Z/C3
		<sup>1)</sup> all types except <sup>2)</sup> SM_						
<b>Axially-locked bearings</b>	Inner bearing cover	D-end internal retaining ring			D-end			
<b>Bearing seals</b>	D-end	V-ring						
	N-end	Labyrinth seal.						
<b>Lubrication</b>		Permanently lubricated shielded bearings.						
		Grease temperature range $-40^{\circ}\text{C}$ to $+160^{\circ}\text{C}$ .						
<b>Terminal box</b>	Material	Diecast aluminum alloy, base integrated with stator.						
	Surface treatment	Similar to stator.						
	Screws	Steel 5G. Galvanised.						
<b>Connections</b>	Knock-out openings	1xM16xPg11	2 x (M20 + M20)		2x(M20+M25)			2x(M20+M25) <sup>1)</sup> 2x(M40+M32+M12) <sup>2)</sup>
		<sup>1)</sup> types S, SB, M, MA. <sup>2)</sup> types SC, MC, SMA, SMB, SMC, SMD, SME						
	Max Cu-area mm <sup>2</sup>	2.5	4		6			10 <sup>1)</sup> 32 <sup>2)</sup>
	Terminal box	Cable lugs, 6 terminals			Screw terminals, 6 terminals			Cable lugs, 6 terminals
<b>Fan</b>	Material	Polypropylene. Reinforced with 20% glass fibre.						
<b>Fan cover</b>	Material	Polypropylene						
<b>Stator winding</b>	Material	Copper.						
	Insulation	Insulation class F.						
	Winding protection	3 PTC thermistors as standard, $150^{\circ}\text{C}$ .						
<b>Rotor winding</b>	Material	Diecast aluminum						
<b>Balancing method</b>		Half key balancing						
<b>Key ways</b>		Closed keyway						
<b>Heating elements</b>	On request	8 W		25 W				
<b>Enclosure</b>		IP 55.						
<b>Cooling method</b>		IC 411						
<b>Drain holes</b>		Drain holes with closable plastic plugs, open on delivery.						

# Industrial performance aluminum motors in brief

Size	M3AA	160	180	200	225	250	280	
<b>Stator</b>	Material	Diecast aluminum alloy.		Extruded aluminum alloy.				
	Paint colour shade	Munsell blue 8B 4.5/3.25 / NCS 4822 B05G						
	Surface treatment	Polyester powder paint, $\geq 100 \mu\text{m}$						
<b>Feet</b>	Material	Aluminum alloy, bolted to the stator		Cast iron, bolted to the stator				
<b>Bearing end shields</b>	Material	Cast iron EN-GJL-200/GG 20/GRS 200						
	Paint colour shade	Munsell blue 8B 4.5/3.25 / NCS 4822 B05G						
	Surface treatment	$\geq 100 \mu\text{m}$		Two-pack epoxy paint, thickness $\geq 100 \mu\text{m}$				
<b>Bearings</b>	D-end	6309-2Z/C3	6310-2Z/C3	6312-2Z/C3	6313-2Z/C3	6315-2Z/C3	6316/C3 <sup>1)</sup>	
	N-end	6209-2Z/C3	6209-2Z/C3	6210-2Z/C3	6212-2Z/C3	6213-2Z/C3	6213/C3	
		<sup>1)</sup> 6315/C3 for 2-pole motors						
<b>Axially-locked bearings</b>	Inner bearing cover	As standard locked at D-end						
<b>Bearing seals</b>		Axial seal as standard						
<b>Lubrication</b>		Permanently lubricated shielded bearings. Wide temperature range grease.					Relubrication. Grease temp. range -40 to 150°C.	
<b>Terminal box</b>	Material	Diecast aluminum alloy, base integrated with stator.		Deep-drawn steel sheet, bolted to stator.				
	Surface treatment	Similar to stator.		Phosphated. Polyester paint.				
	Screws	Steel 8.8, zinc electroplated and chromated						
<b>Connections</b>	Knock-out openings	(2 x M40 + M16) + (2 x M40)		2 x FL13, 2 x M40 + 1 x M16			2 x FL21	
	Flange-openings				Voltage code S; 2 x FL21, 2 x M63 + 1 x M16			2 x M63 1 x M16
	Screws	M6		M10				
	Max Cu-area mm <sup>2</sup>	35		70				
<b>Terminal box</b>		6 terminals for connection with cable lugs (not included)						
<b>Fan</b>	Material	Polypropylene. Reinforced with 20% glass fibre.						
<b>Fan cover</b>	Material	Hot dip galvanized steel						
	Paint colour shade	Blue, Munsell 8B 4.5/3.25 / NCS 4822 B05G						
	Surface treatment	Polyester powder paint, thickness $\geq 100 \mu\text{m}$						
<b>Stator winding</b>	Material	Copper.						
	Insulation	Insulation class F.						
	Winding protection	3 PTC thermistors as standard, 150°C.						
<b>Rotor winding</b>	Material	Diecast aluminum.						
<b>Balancing method</b>		Half key balancing.						
<b>Key ways</b>		Closed keyway						
<b>Heating elements</b>	Optional	25 W	50 W					
<b>Enclosure</b>		IP 55						
<b>Cooling method</b>		IC 411						

# Industrial performance steel motors

## Totally enclosed squirrel cage

### three phase low voltage motors

#### Sizes 280 to 400, 75 to 630 kW



[www.abb.com/motors&generators](http://www.abb.com/motors&generators)

> Motors

>> Low voltage motors

>>> Industrial performance motors



# Mechanical design

## Stator

The stator frame is made of profile-pressed sheet steel, giving the motor high mechanical strength, low weight and a good surface finish. The stator core is welded into the stator frame and contributes to its excellent mechanical properties.

Feet and lifting eyes are welded to the stator frame. The terminal box and end shields are of cast iron.

## Drain holes

Motors that will be operated in very humid or wet environments, and especially under intermittent duty, should be provided with drain holes. The appropriate IM designation, such as IM V3 (IM 3031), is specified, on the basis of the method of motor mounting.

are open on delivery. Check that the drain holes and grease outlet face downwards, when mounting designation differs from standard horizontal mounting.

M2CA motors are fitted with drain holes and plugs. The plugs

in the case of vertical mounting, the upper plug must be hammered home completely. In very dusty environments the drain hole plug should be knocked in.

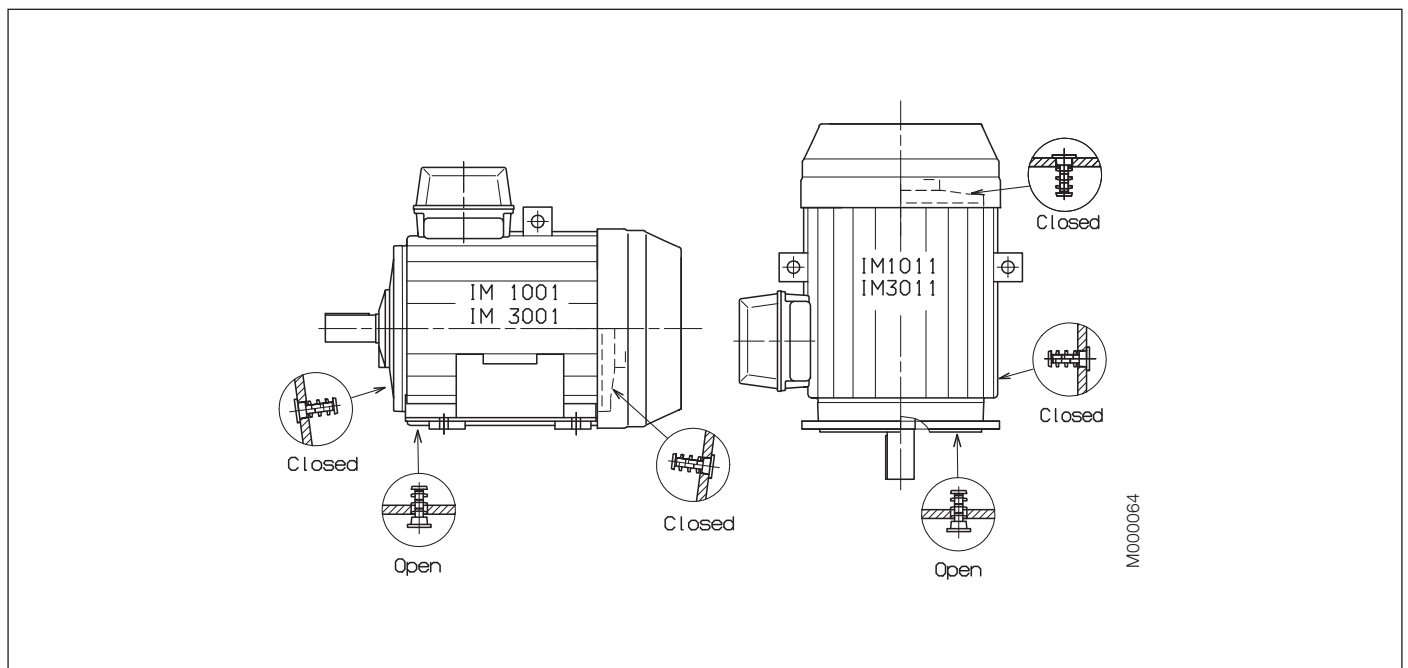

## Terminal box standard delivery

Terminal boxes are mounted on the top of the motor at D-end as standard. The terminal box can also be mounted on the left or right side, see ordering information.

The terminal boxes can be rotated 2x180° to allow cable entry from either side of the motor, as option the terminal box can be turned 4x90°.

Degree of protection of standard terminal box is IP 55. The terminal box is equipped with flanges with cable glands or cable sealing end units. Flange is siliminum as standard. See following pages.

To enable the supply of suitable terminations for the motor, please state cable type, quantity and size when ordering. Non-standard design of terminal boxes; e.g. size, degree of protection, are available as options.

Terminations are suitable for Cu- and Al-cables. Cables are connected to the terminals by cable lugs which are not included in the supply.

Please see variant codes for options.

### Standard delivery if nothing else informed

Motor size	Pole number	Terminal box	Terminal box opening	45° adapter (variant code)	Threaded holes	Cable gland	Cable sealing end unit (variant code)	Cable outer diameter mm	Single core cross-section mm <sup>2</sup> per phase	Terminal bolt size 6 x
280	2-8	122/4	C	-	2xM63	2xM63	-	2xØ32-49	2 x 150	M12
315 S_, M_, L_	2-8	142/4	D	-	2xM63	2xM63	-	2xØ32-49	2 x 240	M12
315 LC	2-4	162/4	E	E-D (294)	-	-	-	2xØ48-60	4 x 240	M12
355 SA, SB	2-8	370	D	-	2xM63	2xM63	-	2xØ32-49	2 x 240	M12
355 MA, MB	2-4	750	E	E-D (294)	-	-	Medium (278)	2xØ48-60	4 x 240	M12
355 MA	6-8	370	D	-	-	-	-	2xØ32-49	2 x 240	M12
355 MB	6	750	E	E-D (294)	-	-	Medium (278)	2xØ48-60	4 x 240	M12
355 MB	8	370	D	-	-	-	-	2xØ32-49	2 x 240	M12
355 LA, LB	2-4	750	E	E-D (294)	-	-	Medium (278)	2xØ48-60	4 x 240	M12
355 LKD	4-6	750	E	E-D (294)	-	-	Large (279)	2xØ60-80	4 x 240	M12
400 MLA, MLB	2-8	750	E	E-D (294)	-	-	Large (279)	2xØ60-80	4 x 240	M12
400 LKA, LKB	2-6	750	E	E-D (294)	-	-	Large (279)	2xØ60-80	4 x 240	M12
<b>Auxiliary cable entries</b>										
280 - 400	2-8				2xM20	2xM20		2xØ60-80		

### Examples of terminal boxes

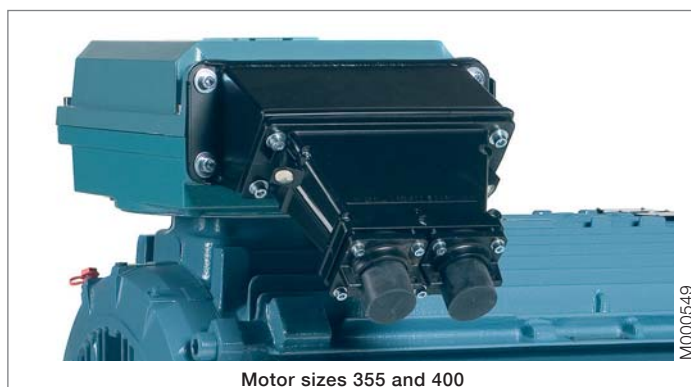

# Terminal box alternatives

There is a broad selection of cable termination accessories available to allow termination of one or several cables. The most common ones are explained below, for other options please contact ABB.

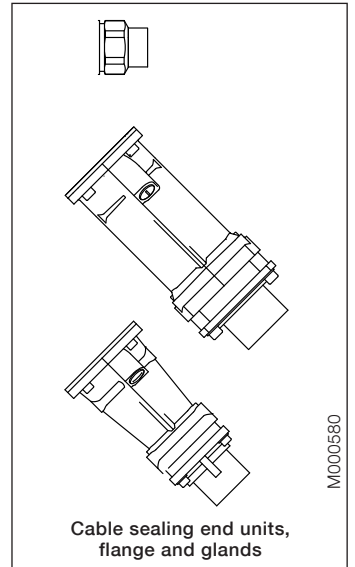
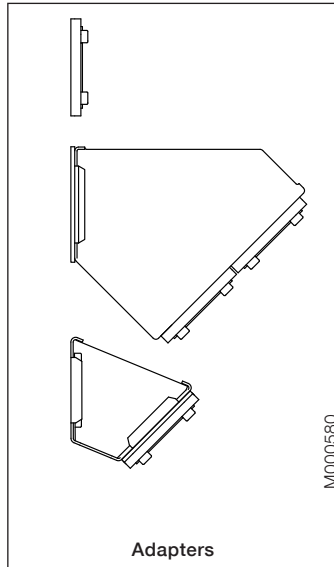
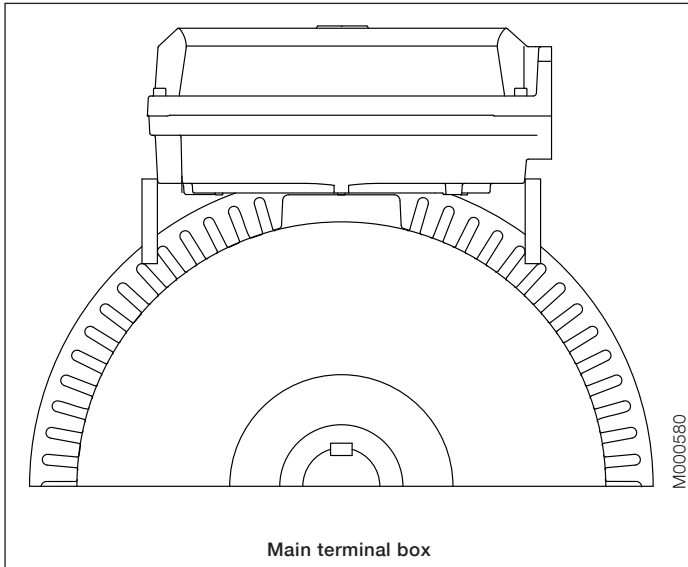

## How to order?

- Check first that the terminal box can allow mounting of the cable and cores (refer to motor type and terminal box type cross reference page 55).
- If very large cables are used it might be necessary to use a larger terminal box than standard. Select the right cable gland(s) or cable sealing end unit(s) depending on outer diameter of the cable(s)
- Select appropriate adapter and flange and gland(s) or cable sealing end unit
- Note that turning the terminal box to a non-standard position might limit the use of some adapters.

## Ordering example

Motor	200 kW, 4 pole, 400 V 50 Hz
Cables	2 pieces, outer diameter 58 mm, single core cross-section 185 mm <sup>2</sup> and clamping device needed cables coming from below.
Needed one terminal box for anticondensation heaters and another for temperature detectors, material must be cast iron.	
Motor	M2CA 315 LA 4-pole, B3
Adapter	D-D - variant code 293
Cable sealing end unit	Variant code 278
Clamping	Variant code 231
Auxiliaries	Variant codes 568, 418

**Main terminal box and maximum single core cross section**  
**Please check also the capability of the cable entry to make sure that the cables fit.**





Standard terminal box	Size of opening	Max single cross section per phase mm <sup>2</sup>
210	C	2 x 240
370	D	2 x 300
750	E	2 x 500



### Optional adapters

To allow easy termination of cables entering the terminal box from above or below it is recommended to use an angle adapter.

These can also be used to allow mounting of several cable sealing end units or flange.

Adapter	Variant code	Opening towards terminal box	Flange or opening for cable sealing end unit	Material	Notes
	M000581 292	C	C	Steel	
	M000582 293	D	D	Steel	
	M000583 294	E	D	Steel	Included in std delivery with 750 type terminal box
	M000584 295	E	2 pcs D	Steel	

### Flange, maximum size of glands and material

Flanges are delivered blind or can be drilled and tapped to accommodate glands to suit the cable diameter and amount of glands needed. Standard flange plate material is aluminum, painted mild steel or stainless steel are available as options.

Size	Examples for maximum size and number of glands, metric		
C	2 x M90	3 x M50	7 x M32
D	4 x M90	7 x M50	4 x M63
E	6 x M90	7 x M63	9 x M50

### Related variant codes

- 729 Aluminum non-drilled flange for cable glands
- 730 Prepared for NPT cable glands
- 743 Painted non-drilled flange in steel for cable glands
- 744 Stainless steel non-drilled flange for cable glands
- 745 Painted steel flange equipped with brass cable glands
- 746 Stainless steel cable flange equipped with standard brass cable glands

## Cable glands and cable sealing end units

### Cable glands

Table below shows the selection of cable gland types and possible cable outer diameter for each size.



Cable gland type	Outer diameter, mm		
	Variant code 745; Painted steel flange equipped with brass cable glands	Variant code 231; Standard cable glands with clamping device	Variant code 704; EMC cable gland
	Motor sizes 280-400	Motor sizes 280-400	Motor sizes 280-400
M20	8-14	8-14	8-14
M25	10-16	10-16	10-16
M32	14-21	14-21	14-21
M40	18-27	18-27	18-27
M50	26-35	26-35	26-35
M63	32-49	32-49	32-49
M75	46-60	NA	NA
M90	55-70	NA	NA

For armoured and NPT cable glands please contact ABB.

### Cable sealing end unit

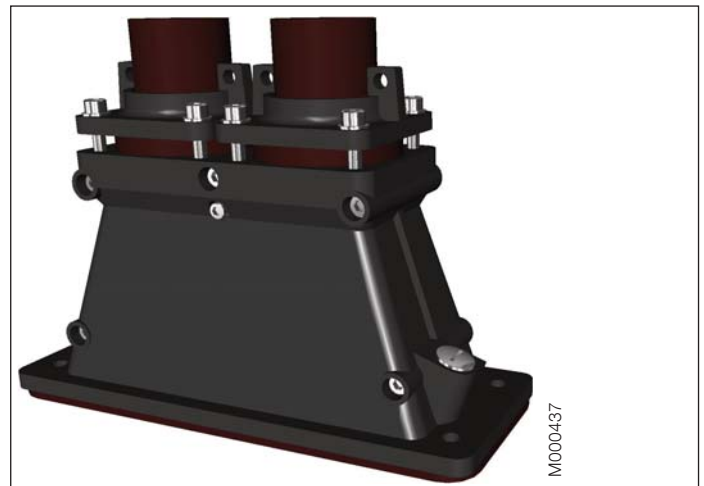
As an alternative to flanges and cable glands, cable sealing units can be used. These allow more space for spreading the cores for easy terminating. Cable sealing end units have rubber sealed entries for one or two main cables. In addition there are two M20 plugged holes for auxiliary cables.



	Variant code	Opening towards terminal box	Cable outer diameter mm	Cable entry auxiliary cable	Accessories	
					Variant code 704; EMC cable gland	Variant code 231; Standard cable gland with clamping device
	M000438 277	C	1 or 2 pcs (40-52) 48-60 mm	2 pcs M20 plugged holes	Optional	Optional
	M000437 278	D	1 or 2 pcs (40-52) 48-60 mm	2 pcs M20 plugged holes	Optional	Optional
	M1000439 279	D	1 or 2 pcs 60-80 mm	2 pcs M20 plugged holes	Optional	Optional

### Auxiliary terminal boxes

It's possible to equip the motors with one or several auxiliary terminal boxes for connection of auxiliaries like heaters or temperature detectors. The standard auxiliary terminal box is made of aluminum and equipped with M20 glands for entry of the connection cables. As an option cast iron box is also available.

Connection terminals are spring loaded type for quick and easy connection. These are suitable for up to 2,5 mm<sup>2</sup> wires. Auxiliary terminal boxes are equipped with an earthing terminal. The first auxiliary terminal box is as standard located a RHS at D-end.

### Related variant codes:

- 380 Separate terminal box for temperature detectors, standard material
- 418 Separate terminal box for auxiliaries, standard material
- 568 Separate terminal box for heating elements, standard material

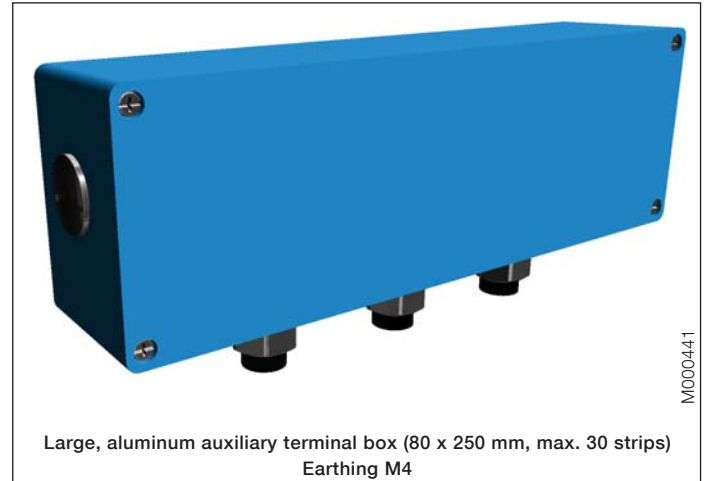
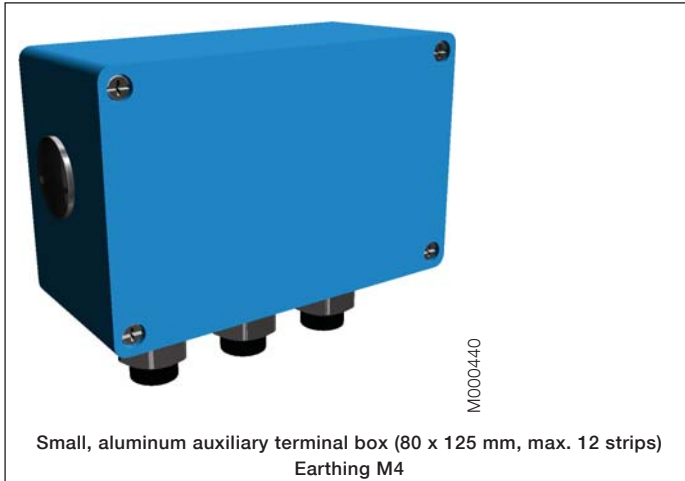

# Dimension drawings

## LV Industrial performance steel motors

Terminal boxes, standard design with 6 terminal

### Dimensions for terminal box inlets

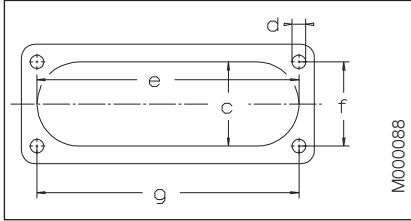

Inlet	c	e	f	g	d
C	62	193	62	193	M8
D	100	300	80	292	M10
E	115	370	100	360	M12

### Motor sizes 280 to 315

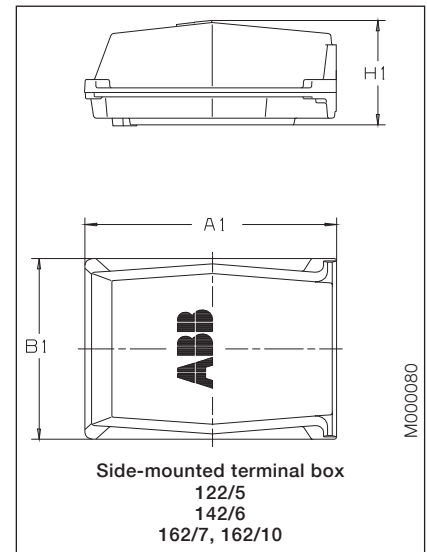
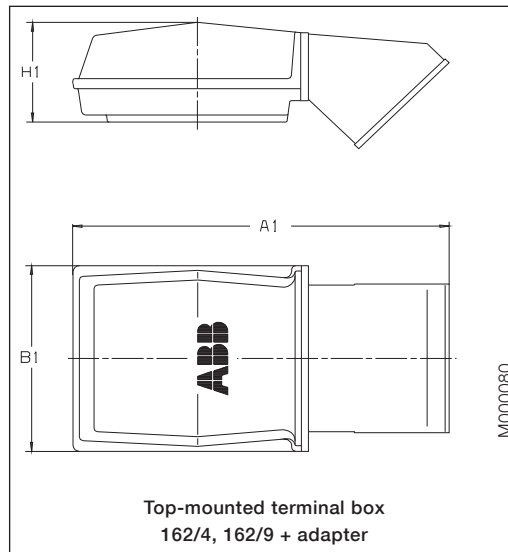
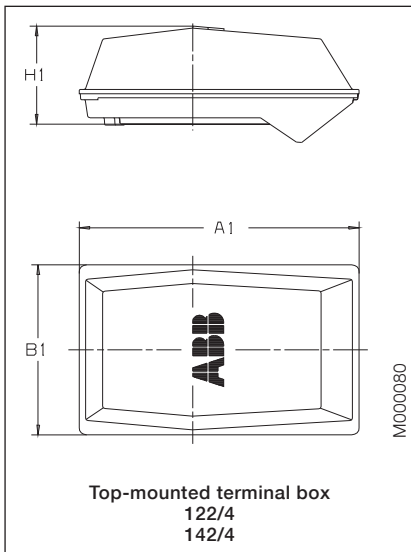

### Motor sizes 355 to 400

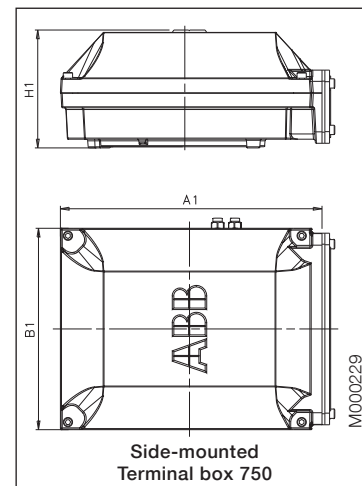
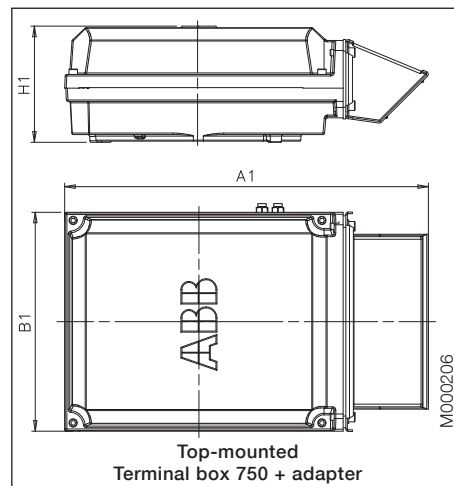
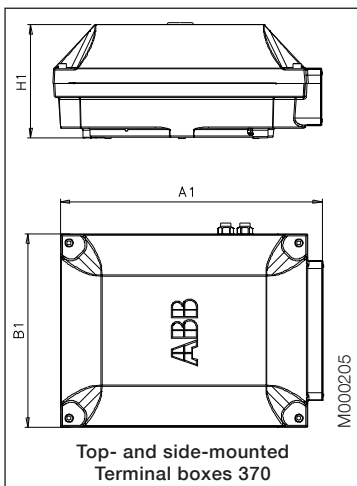

Motor sizes 280 to 315			
Terminal box type	A1	B1	H1
122/4 top-mounted	455	280	177
122/5 side-mounted	383	280	180
142/4 top-mounted	536	349	197
142/6 side-mounted	426	347	201
162/4 + adapter, top-mounted	787	410	226
162/7 side-mounted	508	412	226

Motor sizes 355 to 400			
Terminal box type	A1	B1	H1
370 top- and side-mounted	451	347	200
750 top-mounted	686	413	219
750 side-mounted	525	413	219

For motor dimensions please see dimension drawings on earlier pages or on our web-pages [www.abb.com/motors&generators](http://www.abb.com/motors&generators).

# Bearings

The motors are normally fitted with single-row deep groove ball bearings as listed in the table below. The complete ball bearing designation is stated on the rating plate.

If the bearing at the D-end is replaced with a roller bearing (NU- or NJ-), higher radial forces can be handled. Roller bearings are suitable for belt drive applications.

When there are high axial forces, angular contact ball bearings should be used. This option is available on request. When a motor with angular contact ball bearings is ordered, the method of mounting and direction and magnitude of the axial force must be specified. For special bearings, please see the variant codes.

## Bearing types

Motor size	Number of poles	Standard design Deep groove ball bearings		Alternative designs
		D-end	N-end	Roller bearings variant code 037 D-end
280	2	6316/C4	6316/C4	<sup>1)</sup>
	4-12	6316/C3	6316/C3	NU 316/C3
315	2	6316/C4	6316/C4	<sup>1)</sup>
	4-12	6319/C3	6316/C3	NU319/C3
355	2	6316M/C3	6316M/C3	<sup>1)</sup>
	4-12	6322/C3	6319/C3	NU 322/C3
400	2	6317M/C3	6317M/C3	<sup>1)</sup>
	4-12	6322/C3	6319/C3	NU 322/C3

<sup>1)</sup> On request

## Axially-locked bearings

The outer bearing ring at the D-end is axially locked with an inner bearing cover. The inner ring is locked by tight tolerance to the shaft.

All motors are equipped as standard with an axially-locked bearing at the D-end.

## Transport locking

Motors that have roller bearings or an angular contact ball bearing are fitted with a transport lock before despatch to prevent damage to the bearings during transport. In case of transport locked bearing, the motor is provided with a warning sign.

Locking may also be fitted in other cases where transport conditions are suspected of being potentially damaging.

# Bearing seals

M2CA motors have, as standard, V-rings at both ends. The size and type of suitable seals are in accordance with the table below:

Motor size	Number of poles	d1	d2	B1	b	Standard design Axial seal		Alternative design Radial seal (DIN 3760) Variant code 072
						D-end	N-end	
280	2	80	100	13.5	10	VS 80	VS 80	80x100x10 <sup>1)</sup>
	4-12	80	100	13.5	10	VS 80	VS 80	80x100x10
315	2	80	100	13.5	10	VS 80	VS 80	80x100x10 <sup>1)</sup>
	4-12	95	120	13.5	12	VS 95	VS 80	95x120x12
355	2	95	120	13.5	12	VS 80	VS 80	80x100x10 <sup>1)</sup>
	4-12	110	140	15.5	12	VS 110	VS 95	110x140x12 <sup>1)</sup>
400	2					<sup>2)</sup>	<sup>2)</sup>	
	4-12	110	140	15.5	12	VS 110	VS 95	110x140x12 <sup>1)</sup>

<sup>1)</sup> Viton-seal

<sup>2)</sup> Labyrinth seal

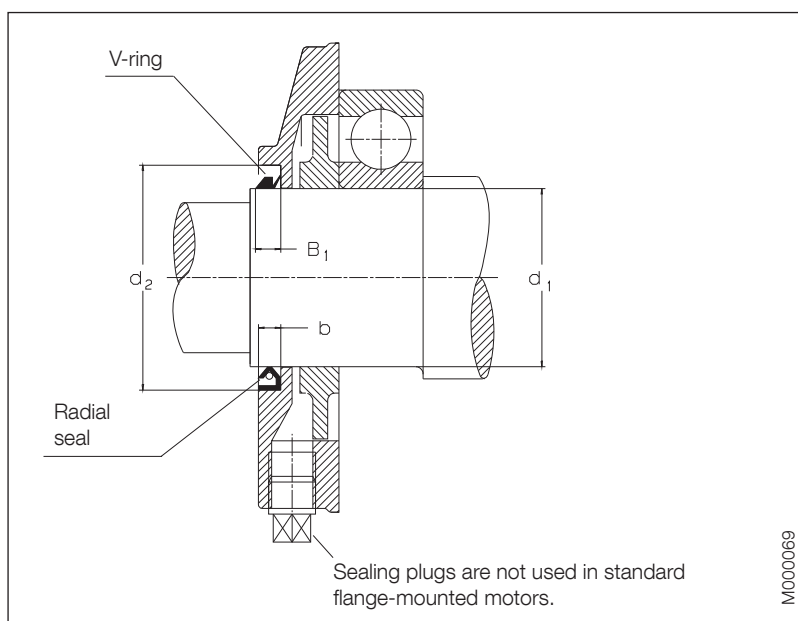

# Bearing life

The nominal life  $L_{10}$  of a bearing is defined according to ISO as the number of operating hours achieved or exceeded by 90 percent of identical bearings in a large test series under certain specified conditions. 50 percent of the bearings achieve at least five times this figure.

The calculated bearing life  $L_{10}$  for power transmission by means of a coupling (horizontal machine):  
Motor sizes M2CA 280 to 400 > 200,000 hours.

# Pulley diameter

When the desired bearing life has been determined, the minimum permissible pulley diameter can be calculated using FR, as follows:

$$D = \frac{1.9 \cdot 10^7 \cdot K \cdot P}{n \cdot F_R}$$

where:

D = diameter of pulley, mm

P = power requirement, kW

n = motor speed, r/min

K = belt tension factor, dependent on belt type and type of duty. A common value for V-belts is 2.5.

FR = permissible radial force

# Permissible loading on shaft

The table below gives the permissible radial and axial forces in Newtons, assuming the occurrence of only radial or axial force. In case of simultaneous radial and axial forces, information can be supplied on request. The values are based on normal conditions at 50 Hz and calculated bearing lives of 40,000 h.

At 60 Hz the values must be reduced by 10 percent. For two-speed motors, the values must be based on the higher speed. When there are high axial forces, angular contact ball bearings should be used.

Motors are B3 version with force directed sideways. In some cases the strength of the shaft affects the permissible forces.

Permissible loads of simultaneous radial and axial forces will be supplied on request.

## Permissible radial and axial force for a bearing life of 40,000 hours

Motor size	Number of poles	Length of shaft extension E (mm)	Permissible radial force:				Permissible axial force:		
			Horizontal mounting, sideways direction of force				Horizontal mounting	Vertical mounting with shaft extension downwards	
			Ball bearing at point of application:		Roller bearing at point of application:		Direction of force		
$\frac{FX_0}{N}$	$\frac{FX_{max}}{N}$	$\frac{FX_0}{N}$	$\frac{FX_{max}}{N}$	Outwards	Upwards	Downwards			
280	2	140	5800	4800	–	–	3700	7050	2600
	4	140	7300	6100	20000	10500	4000	7650	2800
	6	140	8300	6800	22500	10500	4900	8800	3400
	8	140	9200	7500	24700	10500	5700	9750	4100
315	2	140	5800	4900	–	–	3600	7400	1800
	4	170	8900	7300	26500	10500	4900	9200	2800
	6	170	10300	8500	29800	10500	6150	10700	3300
	8	170	11300	9300	32500	11000	6900	11800	4300
355	2	140	5800	5100	–	–	2400	<sup>1)</sup>	<sup>1)</sup>
	4	210	12000	9800	36700	17500	3900	<sup>1)</sup>	<sup>1)</sup>
	6	210	13500	11300	41500	17000	5100	<sup>1)</sup>	<sup>1)</sup>
	8	210	15000	12500	45200	17500	6350	<sup>1)</sup>	<sup>1)</sup>
400	2	170	5800	5100	–	–	6700	<sup>1)</sup>	<sup>1)</sup>
	4	210	11800	10200	37300	16700	3450	<sup>1)</sup>	<sup>1)</sup>
	6	210	13600	11700	42000	13500	4750	<sup>1)</sup>	<sup>1)</sup>
	8	210	15100	12900	45700	16800	5700	<sup>1)</sup>	<sup>1)</sup>

<sup>1)</sup> On request

If the radial force is applied between points  $X_0$  and  $X_{max}$ , the permissible force  $F_R$  can be calculated from the following formula:

$$F_R = F_{X_0} - \frac{X}{E}(FX_0 - FX_{max})$$

E = length of shaft extension in basic version

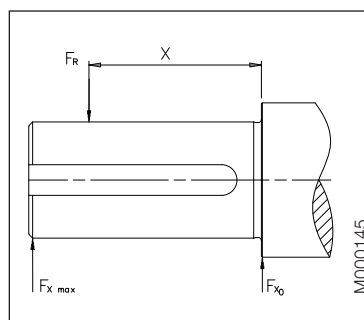

# Rating plate

The rating plate is in table form giving values for speed, current and power factor for three voltages.

The following information must be shown on the motor rating plate according to IEC 60038-30; 2008 and European MEPS (Commission Regulation, EC, No 640/2009):

- Lowest nominal efficiency at 100, 75 and 50 percent rated load
- Efficiency level (IE2 or IE3)
- Year of manufacture

<b>CE</b> <b>IE2</b>						
3 ~ Motor      M2CA 315 SMA 4 B3						
4500678912-10				2009		No. 3GF09123456
					Ins.cl. F	
					IP 55	
V	Hz	kW	r/min	A	cos φ	Duty
690 V	50	132	1486	136	0,85	S1
400 D	50	132	1486	235	0,85	S1
415 D	50	132	1487	229	0,84	S1
IE2 - 95,1 (100%) - 95,2 (75%) - 94,6 (50%)						
Prod. code 3GCA312210-ADA						
					Nmax 2300 r/min	
6319/C3					6319/C3	
					730 kg	
<b>ABB</b> IEC 60034-1						

M000081



# Ordering information

When placing an order, please state the following minimum data in the order, as in the example.

The product code of the motor is composed in accordance with the following example.

<b>Motor type</b>	<b>M2CA 315SMA</b>
<b>Pole number</b>	<b>4</b>
<b>Mounting arrangement (IM-code)</b>	<b>IM B3 (IM 1001)</b>
<b>Rated output</b>	<b>132 kW</b>
<b>Product code</b>	<b>3GCA312210-ADA</b>
<b>Variant codes if needed</b>	

## Motor size

A	B	C	D, E, F,	G
<b>M2CA 315 SMA 3GCA 312 210 - ADA, 003, etc.</b>				
		1 - 4	5 - 6 7   8 - 10	11   12   13   14
A Motor type		D Code for mounting arrangement	E Voltage and frequency code	F Generation code followed by variant codes
B Motor size				G Variant code
C Product code				

## Explanation of the product code

### Positions 1 to 4

**3GCA =**

Totally enclosed fan cooled squirrel cage motor with steel stator frame

### Positions 5 and 6

IEC size

**28 = 280**

**31 = 315**

**35 = 355**

**40 = 400**

### Position 7

Speed (Pole pairs)

**1 = 2 poles**

**2 = 4 poles**

**3 = 6 poles**

**4 = 8 poles**

**5 = 10 poles**

**6 = 12 poles**

**7 = > 12 poles**

**8 = Two-speed motors**

**9 = Multi-speed motors**

### Positions 8 to 10

Serial number

### Position 11

- (dash)

### Position 12

Mounting arrangement

**A = Foot-mounted motor**

**A = Foot-mounted, top-mounted terminal box**

**R = Foot-mounted, terminal box RHS seen from D-end**

**L = Foot-mounted, terminal box LHS seen from D-end**

**B = Flange-mounted, large flange**

**H = Foot- and flange-mounted, top-mounted terminal box**

**S = Foot- and flange-mounted, terminal box RHS seen from D-end**

**T = Foot- and flange-mounted, terminal box LHS seen from D-end**

### Position 13

Voltage and frequency code

Single-speed motors

**B 380 VΔ 50 Hz**

**D 400 VΔ, 415 VΔ, 690 VY 50 Hz**

**E 500 VΔ 50 Hz**

**F 500 VY 50 Hz**

**S 230 VΔ, 400 VY, 415 VY 50 Hz**

**T 660 VΔ 50 Hz**

**U 690 VΔ 50 Hz**

**X Other rated voltage, connection or frequency, 690 V maximum**

Two-speed motors

**A 220 V 50 Hz**

**B 380 V 50 Hz**

**D 400 V 50 Hz**

**E 500 V 50 Hz**

**S 230 V 50 Hz**

**X Other rated voltage, connection or frequency, 690 V maximum**

**Remark:** For voltage code X the variant code '209 Non-standard voltage or frequency (special winding)' must be ordered.

### Position 14

Generation code = A

For frame sizes 280 to 315 = A

For frame sizes 355 to 400 = C

The product code must be, if needed, followed by variant codes.

# Industrial performance steel motors

## Technical data for totally enclosed squirrel cage three phase motors

IE2

P 55 - IC 411 - Insulation class F, temperature rise class B  
IE2 efficiency class according to IEC 60034-30; 2008

Output kW	Motor type	Product code	Speed r/min	Efficiency IEC 60034-2-1; 2007			Power factor cos φ	Current		Torque			Moment of inertia J = 1/4 GD <sup>2</sup> kgm <sup>2</sup>	Weight kg	Sound pressure level L <sub>PA</sub> dB
				Full load 100%	3/4 load 75%	1/2 load 50%		I <sub>N</sub> A	I <sub>s</sub> / I <sub>N</sub>	T <sub>N</sub> Nm	T <sub>l</sub> / T <sub>N</sub>	T <sub>b</sub> / T <sub>N</sub>			
<b>3000 r/min = 2-poles 400 V 50 Hz</b>			<b>CENELEC-design</b>												
75	M2CA 280 SA	3GCA 281 110-••A	2977	94.2	93.8	92.5	0.88	130	7.5	240	2.3	3.3	0.8	480	77
90	M2CA 280 SMA	3GCA 281 210-••A	2975	94.5	94.3	93.3	0.90	152	7.6	288	2.3	2.9	0.9	545	77
110	M2CA 315 SA	3GCA 311 110-••A	2982	94.6	94.1	92.4	0.86	195	7.6	352	2.0	3.0	1.2	695	80
132	M2CA 315 SMA	3GCA 311 210-••A	2982	95.0	94.6	93.3	0.88	227	7.4	422	2.2	3.0	1.4	770	80
160	M2CA 315 MB	3GCA 311 320-••A	2981	95.3	95.0	93.9	0.89	272	7.5	512	2.3	3.0	1.7	840	80
200	M2CA 315 LA	3GCA 311 510-••A	2978	95.6	95.5	94.7	0.90	335	7.8	641	2.6	3.0	2.1	975	80
200	M2CA 355 SA	3GCA 351 110-••C	2978	95.5	95.3	94.3	0.89	339	6.4	641	1.3	2.6	2.5	1200	83
250	M2CA 355 MA	3GCA 351 310-••C	2983	96.1	95.9	94.8	0.89	421	7.2	800	1.4	3.0	2.7	1260	83
280	M2CA 355 MB	3GCA 351 320-••C	2981	96.1	95.9	95.1	0.89	472	6.8	896	1.3	2.8	2.7	1260	83
315	M2CA 355 LA	3GCA 351 510-••C	2980	96.4	96.2	95.5	0.89	529	7.0	1009	2.1	3.0	3.4	1480	83
355	M2CA 355 LB	3GCA 351 520-••C	2983	96.6	96.4	95.7	0.88	602	7.7	1136	2.1	2.9	3.5	1520	83
400	M2CA 400 MLA	3GCA 401 410-••C	2985	96.8	96.6	95.8	0.88	677	7.2	1279	1.4	2.6	6.3	2050	85
450	M2CA 400 MLB	3GCA 401 420-••C	2987	96.9	96.7	96.0	0.90	744	7.7	1438	1.7	3.0	6.9	2150	85
500	M2CA 400 LKA	3GCA 401 810-••C	2987	97.1	96.9	96.2	0.90	825	8.0	1598	2.0	3.2	7.8	2450	85
560	M2CA 400 LKB	3GCA 401 820-••C	2988	97.2	97.1	96.4	0.89	934	7.8	1789	2.1	3.4	7.9	2500	85
<b>3000 r/min = 2-poles 400 V 50 Hz</b>			<b>High-output design</b>												
110	M2CA 280 MB	3GCA 281 320-••A	2977	95.1	95.0	94.2	0.90	185	7.9	352	2.4	3.0	1.15	580	77
132	M2CA 280 MC	3GCA 281 330-••A	2976	95.4	95.4	94.8	0.91	219	7.7	423	2.6	3.0	1.4	755	77
160	M2CA 280 MD	3GCA 281 340-••A	2975	95.6	95.6	95.0	0.91	265	7.9	513	2.8	3.1	1.55	810	77
250	M2CA 315 LB	3GCA 311 520-••A	2980	96.0	96.0	95.3	0.89	422	8.1	801	2.8	2.9	2.65	1230	80
315 <sup>1)</sup>	M2CA 315 LC	3GCA 311 530-••A	2982	96.4	96.3	95.8	0.89	529	8.8	1008	3.2	3.2	3.3	1410	80

<sup>1)</sup> Temperature rise class F

The two bullets in the product code indicate choice of mounting arrangements, voltage and frequency code (see ordering information page).

I<sub>s</sub> / I<sub>N</sub> = Starting current  
T<sub>l</sub> / T<sub>N</sub> = Locked rotor torque  
T<sub>b</sub> / T<sub>N</sub> = Breakdown torque

Efficiency values are given according to IEC 60034-2-1; 2007.

Please note that the values are not comparable without knowing the testing method.

ABB has calculated the efficiency values according to indirect method, stray load losses (additional losses) determined from measuring.

# Industrial performance steel motors

## Technical data for totally enclosed squirrel cage three phase motors

IE2

P 55 - IC 411 - Insulation class F, temperature rise class B  
IE2 efficiency class according to IEC 60034-30; 2008

Output kW	Motor type	Product code	Speed r/min	Efficiency IEC 60034-2-1; 2007			Power factor cos φ	Current		Torque			Moment of inertia J = 1/4 GD <sup>2</sup> kgm <sup>2</sup>	Weight kg	Sound pressure level L <sub>PA</sub> dB
				Full load 100%	3/4 load 75%	1/2 load 50%		I <sub>N</sub> A	I <sub>s</sub> / I <sub>N</sub>	T <sub>N</sub> Nm	T <sub>I</sub> / T <sub>N</sub>	T <sub>b</sub> / T <sub>N</sub>			
<b>1500 r/min = 4-poles</b>		<b>400 V 50 Hz</b>		<b>GENELEC-design</b>											
75	M2CA 280 SA	3GCA 282 110-••A	1483	94.0	94.1	93.4	0.84	137	6.8	482	2.4	2.8	1.15	445	68
90	M2CA 280 SMA	3GCA 282 210-••A	1484	94.6	94.8	94.3	0.85	161	7.1	579	2.7	2.9	1.4	490	68
110	M2CA 315 SA	3GCA 312 110-••A	1487	94.8	94.8	94.0	0.85	197	6.9	706	2.1	2.8	2	675	71
132	M2CA 315 SMA	3GCA 312 210-••A	1486	95.1	95.2	94.6	0.85	235	6.7	848	2.2	2.7	2.3	730	71
160	M2CA 315 MB	3GCA 312 320-••A	1486	95.5	95.6	95.1	0.86	281	7.2	1028	2.4	2.9	2.9	850	71
200	M2CA 315 LA	3GCA 312 510-••A	1486	95.6	95.8	95.4	0.86	351	7.2	1285	2.5	2.9	3.5	970	71
200	M2CA 355 SA	3GCA 352 110-••C	1488	95.6	95.5	94.6	0.86	351	7.3	1283	2.0	2.6	4.8	1200	80
250	M2CA 355 MA	3GCA 352 310-••C	1489	95.8	95.8	95.1	0.86	437	7.5	1603	2.2	2.6	5.7	1320	80
315	M2CA 355 LA	3GCA 352 510-••C	1488	95.8	95.8	95.0	0.86	551	7.3	2021	2.3	2.8	6.9	1550	80
355	M2CA 355 LB	3GCA 352 520-••C	1489	96.1	96.1	95.4	0.86	619	7.5	2276	2.4	2.7	6.9	1550	80
400	M2CA 355 LKD	3GCA 352 840-••C	1490	96.2	96.2	95.5	0.87	689	7.2	2563	2.5	2.8	8.4	1900	85
450	M2CA 400 MLA	3GCA 402 410-••C	1491	96.6	96.5	95.7	0.87	772	7.4	2882	1.9	2.7	12	2300	85
500	M2CA 400 MLB	3GCA 402 420-••C	1491	96.7	96.6	95.8	0.86	867	7.8	3202	2.2	2.9	13	2400	85
560	M2CA 400 LKA	3GCA 402 810-••C	1491	96.7	96.6	95.9	0.85	983	7.4	3586	2.4	3.0	15	2700	85
630 <sup>1)</sup>	M2CA 400 LKB	3GCA 402 820-••C	1491	96.9	96.8	96.2	0.87	1078	7.5	4034	2.2	3.0	16	2800	85
<b>1500 r/min = 4-poles</b>		<b>400 V 50 Hz</b>		<b>High-output design</b>											
110	M2CA 280 MB	3GCA 282 320-••A	1483	94.8	95.1	94.7	0.86	194	7.5	708	2.7	2.8	1.7	550	68
132	M2CA 280 MC	3GCA 282 330-••A	1483	94.9	95.2	94.9	0.86	233	7.1	849	2.8	2.9	2.3	775	70
160	M2CA 280 MD	3GCA 282 340-••A	1483	95.2	95.4	95.0	0.86	282	7.1	1030	2.8	3.1	2.5	820	70
250	M2CA 315 LB	3GCA 312 520-••A	1487	95.5	95.6	95.1	0.86	439	7.4	1605	2.5	2.9	4.4	1200	78
315	M2CA 315 LC	3GCA 312 530-••A	1488	95.6	95.7	95.2	0.86	553	7.8	2021	2.6	3.2	5.5	1380	78

<sup>1)</sup> Temperature rise class F

The two bullets in the product code indicate choice of mounting arrangements, voltage and frequency code (see ordering information page).

I<sub>s</sub> / I<sub>N</sub> = Starting current  
T<sub>I</sub> / T<sub>N</sub> = Locked rotor torque  
T<sub>b</sub> / T<sub>N</sub> = Breakdown torque

Efficiency values are given according to IEC 60034-2-1; 2007.

Please note that the values are not comparable without knowing the testing method.

ABB has calculated the efficiency values according to indirect method, stray load losses (additional losses) determined from measuring.

# Industrial performance steel motors

## Technical data for totally enclosed squirrel cage three phase motors

IE2

P 55 - IC 411 - Insulation class F, temperature rise class B  
IE2 efficiency class according to IEC 60034-30; 2008

Output kW	Motor type	Product code	Speed r/min	Efficiency IEC 60034-2-1; 2007			Power factor cos φ	Current		Torque			Moment of inertia J = 1/4 GD <sup>2</sup> kgm <sup>2</sup>	Weight kg	Sound pressure level L <sub>PA</sub> dB
				Full load 100%	3/4 load 75%	1/2 load 50%		I <sub>N</sub> A	I <sub>s</sub> / I <sub>N</sub>	T <sub>N</sub> Nm	T <sub>l</sub> / T <sub>N</sub>	T <sub>b</sub> / T <sub>N</sub>			
<b>1000 r/min = 6-poles 400 V 50 Hz</b>			<b>GENELEC-design</b>												
45	M2CA 280 SA	3GCA 283 110-••A	990	93.0	93.2	92.5	0.82	85.1	6.6	434	2.5	2.5	1.65	440	66
55	M2CA 280 SMA	3GCA 283 210-••A	989	93.4	93.7	93.3	0.83	102	6.6	531	2.5	2.5	2	475	66
75	M2CA 315 SA	3GCA 313 110-••A	992	94.2	94.3	93.5	0.80	143	7.1	721	2.3	2.7	2.9	630	72
90	M2CA 315 SMA	3GCA 313 210-••A	991	94.6	94.8	94.3	0.83	165	7.1	867	2.3	2.7	3.8	720	72
110	M2CA 315 MB	3GCA 313 320-••A	991	94.7	94.8	94.1	0.83	201	7.3	1059	2.5	2.8	4.5	805	75
132	M2CA 315 LA	3GCA 313 510-••A	990	94.8	95.0	94.4	0.84	239	6.7	1273	2.4	2.7	5.4	910	75
132	M2CA 355 SA	3GCA 353 110-••C	992	94.7	94.6	93.6	0.84	239	6.8	1270	2.0	2.4	6.8	1150	79
160	M2CA 355 SB	3GCA 353 120-••C	992	95.0	95.0	94.1	0.83	292	7.2	1540	2.3	2.5	7.6	1220	79
200	M2CA 355 MA	3GCA 353 310-••C	992	95.2	95.2	94.4	0.83	365	7.5	1925	2.4	2.6	9	1400	79
250	M2CA 355 MB	3GCA 353 320-••C	993	95.4	95.3	94.4	0.80	472	7.7	2404	2.9	3.0	10.6	1550	79
315	M2CA 355 LKD	3GCA 353 840-••C	992	95.7	95.7	95.1	0.82	579	7.4	3032	2.6	2.7	13.2	1900	79
355	M2CA 400 MLA	3GCA 403 410-••C	993	96.2	96.2	95.7	0.84	634	7.3	3413	2.0	2.4	18	2400	80
400	M2CA 400 MLB	3GCA 403 420-••C	994	96.5	96.4	95.8	0.84	712	7.6	3842	2.2	2.7	18	2400	80
450 <sup>1)</sup>	M2CA 400 LKA	3GCA 403 810-••C	994	96.4	96.4	95.8	0.83	811	7.8	4323	2.3	2.6	21	2700	80
500 <sup>1)</sup>	M2CA 400 LKB	3GCA 403 820-••C	994	96.6	96.6	96.1	0.83	900	7.7	4803	2.4	2.5	21	2700	80
<b>1000 r/min = 6-poles 400 V 50 Hz</b>			<b>High-output design</b>												
75	M2CA 280 MB	3GCA 283 320-••A	990	93.7	93.9	93.3	0.83	139	7.3	723	2.8	2.7	2.6	545	67
90	M2CA 280 MC	3GCA 283 330-••A	989	94.0	94.1	93.6	0.84	164	7.4	868	2.9	2.9	3.1	815	67
110	M2CA 280 MD	3GCA 283 340-••A	990	94.3	94.5	93.9	0.85	198	7.9	1061	3.1	3.0	4.1	835	67
<b>750 r/min = 8-poles<sup>2)</sup> 400 V 50 Hz</b>			<b>GENELEC-design</b>												
37	M2CA 280 SA	3GCA 284 110-••A	741	92.2	92.1	90.8	0.78	74.2	7.3	476	1.8	3.1	1.85	460	65
45	M2CA 280 SMA	3GCA 284 210-••A	741	92.5	92.4	91.1	0.78	90	7.6	579	1.9	3.2	2.2	500	65
55	M2CA 315 SA	3GCA 314 110-••A	741	93.2	93.3	92.4	0.80	106	7.1	708	1.8	2.8	2.9	630	70
75	M2CA 315 SMA	3GCA 314 210-••A	740	93.4	93.7	93.1	0.81	143	7.1	967	1.8	2.8	3.8	715	70
90	M2CA 315 MB	3GCA 314 320-••A	740	93.7	93.9	93.5	0.82	169	7.3	1161	1.9	2.8	4.5	800	77
110	M2CA 315 LA	3GCA 314 510-••A	740	93.7	94.1	93.8	0.83	204	7.0	1419	1.9	2.7	5.4	900	77
110	M2CA 355 SA	3GCA 354 110-••C	743	94.3	94.4	93.7	0.80	210	6.0	1413	1.0	2.4	6.8	1150	75
132	M2CA 355 MA	3GCA 354 310-••C	743	94.5	94.6	93.9	0.80	252	6.2	1696	1.0	2.4	7.6	1220	75
160	M2CA 355 MB	3GCA 354 320-••C	744	94.7	94.7	94.0	0.79	308	6.8	2053	1.2	2.7	9	1400	75
<b>750 r/min = 8-poles 400 V 50 Hz</b>			<b>High-output design</b>												
55	M2CA 280 MB	3GCA 284 320-••A	741	93.0	93.1	92.1	0.79	108	7.8	708	1.9	3.2	2.85	575	65

<sup>1)</sup> Temperature rise class F

The two bullets in the product code indicate choice of mounting

I<sub>s</sub> / I<sub>N</sub> = Starting current

<sup>2)</sup> Efficiency classification concerns 2-, 4- and 6-pole motors.

arrangements, voltage and frequency code (see ordering information page).

T<sub>l</sub> / T<sub>N</sub> = Locked rotor torque

T<sub>b</sub> / T<sub>N</sub> = Breakdown torque

Efficiency values are given according to IEC 60034-2-1; 2007.

Please note that the values are not comparable without knowing the testing method.

ABB has calculated the efficiency values according to indirect method, stray load losses (additional losses) determined from measuring.

# Industrial performance steel motors – variant codes

Code <sup>1)</sup> Variant	Frame size				
	280	315	355	400	
<b>Administration</b>					
531	Sea freight packing	M	M	M	P
<b>Balancing</b>					
417	Vibration acc. to Grade B (IEC 60034-14).	P	P	P	R
423	Balanced without key.	P	P	P	P
424	Full key balancing.	P	P	P	P
<b>Bearings and Lubrication</b>					
036	Transport lock for bearings.	M	M	M	P
037	Roller bearing at D-end.	M	M	M	R
040	Heat resistant grease.	M	M	M	P
043	SPM compatible nipples for vibration measurement	M	M	M,P	P
058	Angular contact bearing at D-end, shaft force away from bearing.	P	P	P	P
060	Angular contact bearing at D-end, shaft force towards bearing.	P	P	P	P
107	Pt100 2-wire in bearings.	P	P	P	P
128	Double PT100, 2-wire in bearings	P	P	P	P
129	Double PT100, 3-wire in bearings	P	P	P	P
130	Pt100 3-wire in bearings.	P	P	P	P
420	Bearing mounted PTC thermistors.	P	P	P	P
795	Lubrication information plate	P	P	P	P
796	Grease nipples JIS B 1575 PT 1/8 Type A	M	M	M	P
799	Grease nipples flat type DIN 3404, thread M10x1	M	M	M	P
800	Grease nipples JIS B 1575 PT 1/8" pin type	M	M	M	P
<b>Branch standard designs</b>					
142	"Manilla connection".	P	P	R	R
178	Stainless steel / acid proof bolts.	P	P	P	P
209	Non-standard voltage or frequency, (special winding).	P	P	P	P
425	Corrosion protected stator and rotor core.	P	P	P	P
<b>Cooling system</b>					
044	Unidirectional fan for reduced noise level. Rotation clockwise seen from D-end. Available only for 2-pole motors.	P	P	P	P
045	Unidirectional fan for reduced noise level. Rotation counter clockwise seen from D-end. Available only for 2-pole motors.	P	P	P	P
068	Light alloy metal fan	P	P	P	P
075	Cooling method IC418 (without fan).	R	R	R	R
<b>Coupling</b>					
035	Assembly of customer supplied coupling-half.	P	P	P	P
<b>Documentation</b>					
141	Binding dimension drawing.	M	M	M	P
<b>Drain holes</b>					
065	Plugged existing drain holes.	M	M	M	P
<b>Earthing Bolt</b>					
067	External earthing bolt.	M	M	M	P
<b>Hazardous Environments</b>					
See catalog „Motors for hazardous Environments“ for details.					
<b>Heating elements</b>					
450	Heating element, 100-120V.	M	M	M	P
451	Heating element, 200-240V.	M	M	M	P
<b>Insulation system</b>					
014	Winding insulation class H.	P	P	P	P
405	Special winding insulation for frequency converter supply.	P	P	P	P

<sup>1)</sup> Certain variant codes cannot be used simultaneously.

S = Included as standard.  
M = On modification of a stocked motor,  
or on new manufacture,  
the number per order may be limited.  
P = New manufacture only.  
R = On request.  
NA = Not applicable.

Code <sup>1)</sup> Variant		Frame size			
		280	315	355	400
<b>Mounting arrangements</b>					
009	IM 2001 foot/flange mounted, IEC flange, from IM 1001 (B35 from B3).	M	M	M	P
066	Modified for non-standard mounting position (please specify IM xxxx), (must be ordered for all mounting arrangements excluding IM B3 (1001), IM B5 (3001), IM B35 (2001), B34 (2101) & B14 (3601).	M	M	M	P
<b>Painting</b>					
109	Paint thickness = 120 µm.	M	M	M	P
110	Paint thickness = 160 µm.	M	M	M	P
114	Special paint colour, standard grade.	M	M	M	P
<b>Protection</b>					
005	Metal protective roof, vertical motor, shaft down.	M	M	M	P
072	Radial seal at D-end.	M	M	M	P
158	Degree of protection IP65.	M	M	M	P
403	Degree of protection IP56.	M	M	M	P
<b>Rating &amp; instruction plates</b>					
002	Restamping voltage, frequency and output, continuous duty.	M	M	M	P
004	Additional text on std rating plate (max 12 digits on free text line).	M	M	M	P
095	Restamping output (maintained voltage, frequency), intermittent duty.	M	M	M	P
126	Tag plate	P	P	P	P
135	Mounting of additional identification plate, stainless.	M	M	M	P
139	Additional identification plate delivered loose.	M	M	M	P
161	Additional rating plate delivered loose.	M	M	M	P
163	Frequency converter rating plate. Rating data according to quotation.	P	P	P	P
<b>Shaft &amp; rotor</b>					
069	Two shaft extensions as per basic catalogue.	P	P	P	P
070	One or two special shaft extensions, standard shaft material.	P	P	P	P
410	Stainless steel shaft (standard or non-standard design).	P	P	P	P
<b>Standards and Regulations</b>					
010	Fulfilling CSA Safety Certificate.	P	P	P	P
540	China energy label	M	M	M	NA
779	SASO Export/Import Certificate (Saudi Arabia)	M	M	M	P
<b>Stator winding temperature sensors</b>					
120	KTY 84-130 (1 per phase) in stator winding.	P	P	P	P
121	Bimetal detectors, break type (NCC), (3 in series), 130°C, in stator winding.	M	M	M	P
122	Bimetal detectors, break type (NCC), (3 in series), 150°C, in stator winding.	M	M	M	P
123	Bimetal detectors, break type (NCC), (3 in series), 170°C, in stator winding.	M	M	M	P
125	Bimetal detectors, break type (NCC), (2x3 in series), 150°C, in stator winding.	P	P	P	P
127	Bimetal detectors, break type (NCC), (3 in series, 130°C & 3 in series, 150°C), in stator winding.	M	M	M	P
435	PTC - thermistors (3 in series), 130°C, in stator winding.	M	M	M	P
436	PTC - thermistors (3 in series), 150°C, in stator winding.	S	S	S	S
437	PTC - thermistors (3 in series), 170°C, in stator winding.	M	M	M	P
439	PTC - thermistors (2x3 in series), 150°C, in stator winding.	M	M	M	P
441	PTC - thermistors (3 in series, 130°C & 3 in series, 150°C), in stator winding.	M	M	M	P
442	PTC - thermistors (3 in series, 150°C & 3 in series, 170°C), in stator winding.	M	M	M	P
445	Pt-100 2-wire in stator winding, 1 per phase	M	M	M	P
446	Pt-100 2-wire in stator winding, 2 per phase	M	M	M	P
502	Pt-100 3-wire in stator winding, 1 per phase.	M	M	M	P
503	Pt-100 3-wire in stator winding, 2 per phase.	M	M	M	P
<b>Terminal box</b>					
019	Larger than standard terminal box.	R	R	R	R
021	Terminal box LHS (seen from D-end).	P	P	P	P
022	Cable entry LHS (seen from D-end).	M	M	M	P
157	Terminal box degree of protection IP65.	M	M	M	P
180	Terminal box RHS (seen from D-end).	P	P	P	P

<sup>1)</sup> Certain variant codes cannot be used simultaneously.

S = Included as standard.  
M = On modification of a stocked motor,  
or on new manufacture,  
the number per order may be limited.  
P = New manufacture only.  
R = On request.  
NA = Not applicable.

Code <sup>1)</sup> Variant	Frame size				
	280	315	355	400	
277	Cable sealing end unit, size small for C-opening	P	NA	NA	NA
278	Cable sealing end unit, size medium for D-opening	NA	P	S	S
279	Cable sealing end unit, size large for D-opening	NA	P	P	P
292	Adapter C-C	P	NA	NA	NA
293	Adapter D-D	NA	P	P	P
294	Adapter E-D	NA	NA	S	S
295	Adapter E-2D	NA	NA	P	P
380	Separate terminal box for temperature detectors, std. material	P	P	P	P
413	Extended cable connection, no terminal box.	P	P	P	P
418	Separate terminal box for auxiliaries, standard material.	P	P	P	P
466	Terminal box at N-end.	P	P	P	P
468	Cable entry from D-end.	P	P	P	P
469	Cable entry from N-end.	P	P	P	P
568	Separate terminal box for heating elements, std. material	P	P	P	P
729	Aluminum non-drilled flange for cable glands	M	M	M	P
730	Prepared for NPT cable glands	P	P	P	P
743	Painted non-drilled flange in steel for cable glands	M	M	M	P
744	Stainless steel non-drilled flange for cable glands.	P	P	P	P
745	Painted steel flange equipped with nickle plated brass cable glands	M	M	M	P
746	Stainless steel cable flange equipped with standard nickle plated brass cable glands	P	P	P	P
<b>Testing</b>					
145	Type test report from a catalogue motor, 400V 50Hz.	M	M	M	P
146	Type test with report for one motor from specific delivery batch.	P	P	P	P
148	Routine test report.	M	M	M	P
150	Customer witnessed testing. Specify test procedure with other codes.	P	P	P	P
222	Torque/speed curve, type test and multi-point load test with report for one motor from specific delivery batch.	P	P	P	P
760	Vibration level test	P	P	P	P
761	Vibration spectrum test for one motor from specific delivery batch.	P	P	P	P
762	Noise level test for one motor from specific delivery batch.	P	P	P	P
763	Noise spectrum test for one motor from specific delivery batch.	P	P	P	P
<b>Variable speed drives</b>					
701	Insulated bearing at N-end.	M	M	M	P
704	EMC cable gland.	M	M	M	P
<b>Y/Δ starting</b>					
117	Terminals for Y/Δ start at both speeds (two speed windings).	P	P	R	R
118	Terminals for Y/Δ start at high speed (two speed windings).	P	P	R	R
119	Terminals for Y/Δ start at low speed (two speed windings).	P	P	R	R

<sup>1)</sup> Certain variant codes cannot be used simultaneously.

S = Included as standard.

M = On modification of a stocked motor,  
or on new manufacture,  
the number per order may be limited.

P = New manufacture only.

R = On request.

NA = Not applicable.

# Industrial performance steel motors Dimension drawings

## M2CA 280 - 315

Foot-mounted; IM B3 (IM 1001), IM B6 (IM 1051), IM B7 (IM 1061), IM B8 (IM 1071),  
IM V5 (IM 1011), IM V6 (IM 1031) – terminal box top mounted

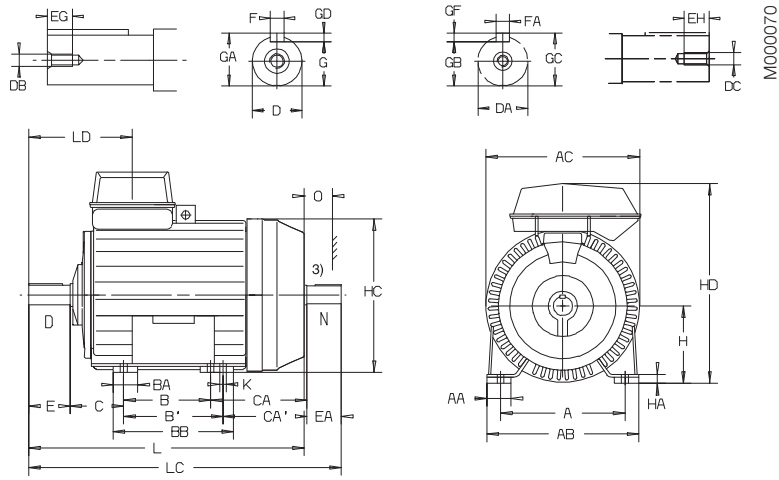

M000070

Motor size	Poles <sup>1)</sup>	Dimensions (mm)																		
		A	AA	AB	AC	B	B'	BA	BB	C	CA	CA'	D	DA	DB	DC	E	EA	EG	EH
280 SA	2	457	80	545	555	368	-	100	501	190	372	-	65	60	M20	M20	140	140	40	40
	4-8	457	80	545	555	368	-	100	450	190	302	-	75	65	M20	M20	140	140	40	40
280 SMA	2	457	80	545	555	368	419	100	501	190	372	321	65	60	M20	M20	140	140	40	40
	4-8	457	80	545	555	368	419	100	501	190	372	321	75	65	M20	M20	140	140	40	40
280 MB	2	457	80	545	555	419	-	100	501	190	381	-	65	60	M20	M20	140	140	40	40
	4-8	457	80	545	555	419	-	100	501	190	381	-	75	65	M20	M20	140	140	40	40
280 MC,MD	2	457	80	545	555	419	-	100	501	190	381	-	65	60	M20	M20	140	140	40	40
	4-8	457	80	545	555	419	-	100	501	190	381	-	75	65	M20	M20	140	140	40	40
315 SA	2	508	100	622	624	406	-	100	539	216	343	-	65	60	M20	M20	140	140	40	40
	4-8	508	100	622	624	406	-	100	539	216	343	-	80	75	M20	M20	170	140	40	40
315 SMA	2	508	100	622	624	406	457	100	539	216	443	392	65	60	M20	M20	140	140	40	40
	4-8	508	100	622	624	406	457	100	539	216	343	292	80	75	M20	M20	170	140	40	40
315 MB	2	508	100	622	624	457	-	100	539	216	392	-	65	60	M20	M20	140	140	40	40
	4-8	508	100	622	624	457	-	100	539	216	392	-	80	75	M20	M20	170	140	40	40
315 LA	2	508	100	622	624	508	-	100	592	216	411	-	65	60	M20	M20	140	140	40	40
	4-8	508	100	622	624	508	-	100	592	216	411	-	90	75	M24	M20	170	140	48	40
315 LB,LC	2	508	100	622	624	508	-	100	592	216	411	-	65	60	M20	M20	140	140	40	40
	4-8	508	100	622	624	508	-	100	592	216	411	-	90	75	M24	M20	170	140	48	40

Motor size	Poles <sup>1)</sup>	Dimensions (mm)																	O <sup>2)</sup>
		F	FA	G	GA	GB	GC	GD	GF	H	HA	HC	HD	K	L	LC	LD		
280 SA	2	18	18	58	69	53	64	11	11	280	32	558	730	24	1060	1210	385	100	
	4-8	20	18	67.5	79.5	58	69	12	11	280	32	558	730	24	990	1140	385	100	
280 SMA	2	18	18	58	69	53	64	11	11	280	32	558	730	24	1060	1210	385	100	
	4-8	20	18	67.5	79.5	58	69	12	11	280	32	558	730	24	1060	1210	385	100	
280 MB	2	18	18	58	69	53	64	11	11	280	32	558	730	24	1120	1270	385	100	
	4-8	20	18	67.5	79.5	58	69	12	11	280	32	558	730	24	1120	1270	385	100	
280 MC	2	18	18	58	69	53	64	11	11	280	32	555	730	24	1255	1405	385	100	
	4-8	20	18	67.5	79.5	58	69	12	11	280	32	558	730	24	1255	1405	385	100	
280 MD	2	18	18	58	69	53	64	11	11	280	32	558	730	24	1255	1405	385	100	
	4-8	20	18	67.5	79.5	58	69	12	11	280	32	558	730	24	1255	1405	385	100	
315 SA	2	18	18	58	69	53	64	11	11	315	32	627	820	28	1095	1245	390	115	
	4-8	22	20	71	85	67.5	79.5	14	12	315	32	627	820	28	1125	1275	420	115	
315 SMA	2	18	18	58	69	53	64	11	11	315	32	627	820	28	1195	1345	390	115	
	4-8	22	20	71	85	67.5	79.5	14	12	315	32	627	820	28	1125	1275	420	115	
315 MB	2	18	18	58	69	53	64	11	11	315	32	627	820	28	1195	1345	390	115	
	4-8	22	20	71	85	67.5	79.5	14	12	315	32	627	820	28	1225	1375	420	115	
315 LA	2	18	18	58	69	53	64	11	11	315	32	627	820	28	1265	1415	390	115	
	4-8	25	20	81	95	67.5	79.5	14	12	315	32	627	820	28	1295	1445	420	115	
315 LB	2	18	18	58	69	53	64	11	11	315	32	627	820	28	1545	1695	390	115	
	4-8	25	20	81	95	67.5	79.5	14	12	315	32	627	820	28	1575	1725	420	115	
315 LC	2	18	18	58	69	53	64	11	11	315	32	627	848	28	1545	1695	390	115	
	4	25	20	81	95	67.5	79.5	14	12	315	32	627	848	28	1575	1725	420	115	

Tolerances:

A, B	ISO js14	H	ISO 0, -1.0
D, DA	ISO m6		
F, FA	ISO h9		

- <sup>1)</sup> Dimensions for 4-pole motors also valid for 4/6- and 4-8 -pole two-speed motors.
- <sup>2)</sup> Cooling distance.
- <sup>3)</sup> Second shaft end on request.

Above table gives the main dimensions in mm.  
For detailed drawings please see our web-pages '[www.abb.com/motors&generators](http://www.abb.com/motors&generators)' or contact ABB.



# Industrial performance steel motors

## Dimension drawings

# M2CA 280 - 315

Foot-mounted; IM B3 (IM 1001), IM B6 (IM 1051), IM B7 (IM 1061), IM B8 (IM 1071), IM V5 (IM 1011), IM V6 (IM 1031) – terminal box side mounted

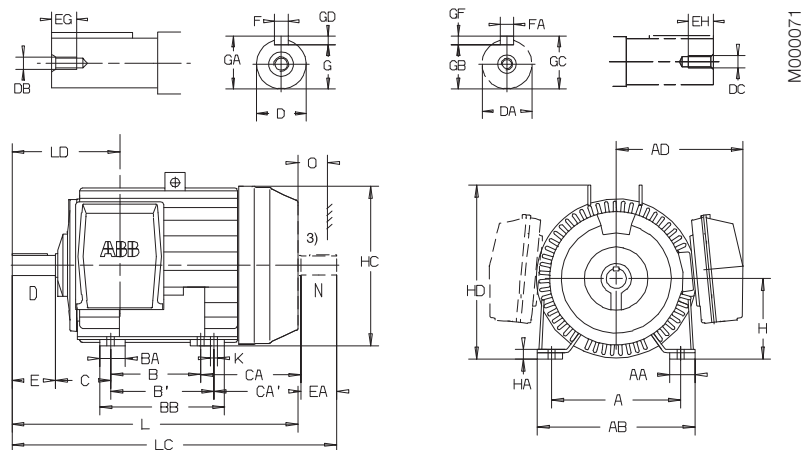

M000071

Motor size	Poles <sup>1)</sup>	A	AA	AB	AD	B	B'	BA	BB	C	CA	CA'	D	DA	DB	DC	E	EA	EG	EH
		280 SA	2	457	80	545	448	368	-	100	501	190	372	-	65	60	M20	M20	140	140
	4-8	457	80	545	448	368	-	100	450	190	302	-	75	65	M20	M20	140	140	40	40
280 SMA	2	457	80	545	448	368	419	100	501	190	372	321	65	60	M20	M20	140	140	40	40
	4-8	457	80	545	448	368	419	100	501	190	372	321	75	65	M20	M20	140	140	40	40
280 MB	2	457	80	545	448	419	-	100	501	190	381	-	65	60	M20	M20	140	140	40	40
	4-8	457	80	545	448	419	-	100	501	190	381	-	75	65	M20	M20	140	140	40	40
280 MC,MD	2	457	80	545	448	419	-	100	501	190	381	-	65	60	M20	M20	140	140	40	40
	4-8	457	80	545	448	419	-	100	501	190	381	-	75	65	M20	M20	140	140	40	40
315 SA	2	508	100	622	502	406	-	100	539	216	343	-	65	60	M20	M20	140	140	40	40
	4-8	508	100	622	502	406	-	100	539	216	343	-	80	75	M20	M20	170	140	40	40
315 SMA	2	508	100	622	502	406	457	100	539	216	443	392	65	60	M20	M20	140	140	40	40
	4-8	508	100	622	502	406	457	100	539	216	343	292	80	75	M20	M20	170	140	40	40
315 MB	2	508	100	622	502	457	-	100	539	216	392	-	65	60	M20	M20	140	140	40	40
	4-8	508	100	622	502	457	-	100	539	216	392	-	80	75	M20	M20	170	140	40	40
315 LA	2	508	100	622	502	508	-	100	592	216	411	-	65	60	M20	M20	140	140	40	40
	4-8	508	100	622	502	508	-	100	592	216	411	-	90	75	M24	M20	170	140	48	40
315 LB,LC	2	508	100	622	502	508	-	100	592	216	411	-	65	60	M20	M20	140	140	40	40
	4-8	508	100	622	502	508	-	100	592	216	411	-	90	75	M24	M20	170	140	48	40

Motor size	Poles <sup>1)</sup>	F	FA	G	GA	GB	GC	GD	GF	H	HA	HC	HD	K	L	LC	LD	O <sup>2)</sup>
		280 SA	2	18	18	58	69	53	64	11	11	280	32	558	620	24	1060	1210
	4-8	20	18	67.5	79.5	58	69	12	11	280	32	558	620	24	990	1140	385	100
280 SMA	2	18	18	58	69	53	64	11	11	280	32	558	620	24	1060	1210	385	100
	4-8	20	18	67.5	79.5	58	69	12	11	280	32	558	620	24	1060	1210	385	100
280 MB	2	18	18	58	69	53	64	11	11	280	32	558	620	24	1120	1270	385	100
	4-8	20	18	67.5	79.5	58	69	12	11	280	32	558	620	24	1120	1270	385	100
280 MC	2	18	18	58	69	53	64	11	11	280	32	558	620	24	1255	1405	385	100
	4-8	20	18	67.5	79.5	58	69	12	11	280	32	558	620	24	1255	1405	385	100
280 MD	2	18	18	58	69	53	64	11	11	280	32	558	620	24	1255	1405	385	100
	4-8	20	18	67.5	79.5	58	69	12	11	280	32	558	620	24	1255	1405	385	100
315 SA	2	18	18	58	69	53	64	11	11	315	32	627	685	28	1095	1245	390	115
	4-8	22	20	71	85	67.5	79.5	14	12	315	32	627	685	28	1125	1275	420	115
315 SMA	2	18	18	58	69	53	64	11	11	315	32	627	685	28	1195	1345	390	115
	4-8	22	20	71	85	67.5	79.5	14	12	315	32	627	685	28	1125	1275	420	115
315 MB	2	18	18	58	69	53	64	11	11	315	32	627	685	28	1195	1345	390	115
	4-8	22	20	71	85	67.5	79.5	14	12	315	32	627	685	28	1225	1375	420	115
315 LA	2	18	18	58	69	53	64	11	11	315	32	627	685	28	1265	1415	390	115
	4-8	25	20	81	95	67.5	79.5	14	12	315	32	627	685	28	1295	1445	420	115
315 LB,LC	2	18	18	58	69	53	64	11	11	315	32	627	685	28	1545	1695	390	115
	4-8	25	20	81	95	67.5	79.5	14	12	315	32	627	685	28	1575	1575	420	115

Tolerances:

A, B	ISO js14	H	ISO 0, -1.0
D, DA	ISO m6		
F, FA	ISO h9		

- <sup>1)</sup> Dimensions for 4-pole motors also valid for 4/6- and 4-8 -pole two-speed motors.
- <sup>2)</sup> Cooling distance.
- <sup>3)</sup> Second shaft end on request.

Above table gives the main dimensions in mm.  
For detailed drawings please see our web-pages '[www.abb.com/motors&generators](http://www.abb.com/motors&generators)' or contact ABB.

# Industrial performance steel motors

## Dimension drawings

# M2CA 280 - 315

Flange-mounted; IM B5 (IM 3001), V1 (IM 3011), V3 (IM 3031) and IM B14 (IM 3601), V18 (IM 3611), V19 (IM 3631)

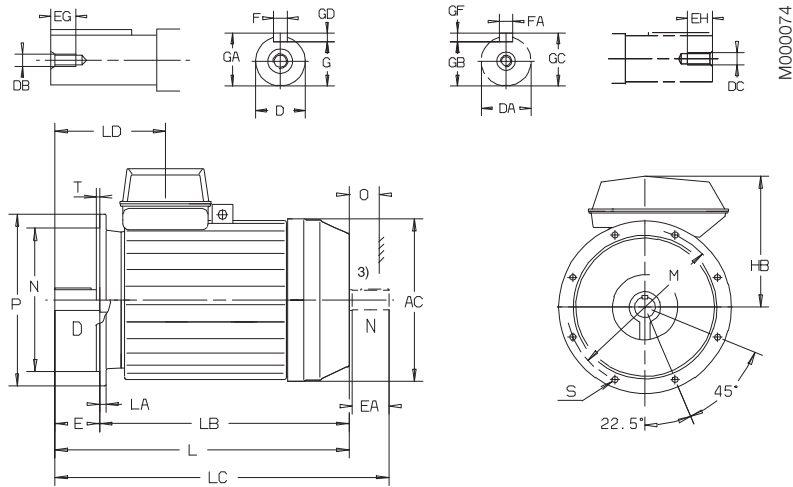

Motor size	Poles <sup>1)</sup>	AC	D	DA	DB	DC	E	EA	EG	EH	F	FA	G	GA	GB	GC
280 SA	2	555	65	60	M20	M20	140	140	40	40	18	18	58	69	53	64
	4-8	555	75	65	M20	M20	140	140	40	40	20	18	67.5	79.5	58	69
280 SMA	2	555	65	60	M20	M20	140	140	40	40	18	18	58	69	53	64
	4-8	555	75	65	M20	M20	140	140	40	40	20	18	67.5	79.5	58	69
280 MB	2	555	65	60	M20	M20	140	140	40	40	18	18	58	69	53	64
	4-8	555	75	65	M20	M20	140	140	40	40	20	18	67.5	79.5	58	69
280 MC,MD	2	555	65	60	M20	M20	140	140	40	40	18	18	58	69	53	64
	4-8	555	75	65	M20	M20	140	140	40	40	20	18	67.5	79.5	58	69
315 SA	2	624	65	60	M20	M20	140	140	40	40	18	18	58	69	53	64
	4-8	624	80	75	M20	M20	170	140	40	40	22	20	71	85	67.5	79.5
315 SMA	2	624	65	60	M20	M20	140	140	40	40	18	18	58	69	53	64
	4-8	624	80	75	M20	M20	170	140	40	40	22	20	71	85	67.5	79.5
315 MB	2	624	65	60	M20	M20	140	140	40	40	18	18	58	69	53	64
	4-8	624	80	75	M20	M20	170	140	40	40	22	20	71	85	67.5	79.5
315 LA	2	624	65	60	M20	M20	140	140	40	40	18	18	58	69	53	64
	4-8	624	90	75	M24	M20	170	140	48	40	25	20	81	95	67.5	79.5
315 LB,LC	2	624	65	60	M20	M20	140	140	40	40	18	18	58	69	53	64
	4-8	624	90	75	M24	M20	170	140	48	40	25	20	81	95	67.5	79.5

Motor size	Poles <sup>1)</sup>	GD	GF	HB	L	LA	LB	LC	LD	M	N	O <sup>2)</sup>	P	S	T
280 SA	2	11	11	450	1060	22	920	1210	385	500	450	100	550	18	5
	4-8	12	11	450	990	22	850	1140	385	500	450	100	550	18	5
280 SMA	2	11	11	450	1060	22	920	1210	385	500	450	100	550	18	5
	4-8	12	11	450	1060	22	920	1210	385	500	450	100	550	18	5
280 MB	2	11	11	450	1120	22	980	1270	385	500	450	100	550	18	5
	4-8	12	11	450	1120	22	980	1270	385	500	450	100	550	18	5
280 MC	2	11	11	450	1255	22	980	1405	385	500	450	100	550	18	5
	4-8	12	11	450	1255	22	980	1405	385	500	450	100	550	18	5
280 MD	2	11	11	450	1255	22	980	1405	385	500	450	100	550	18	5
	4-8	12	11	450	1255	22	980	1405	385	500	450	100	550	18	5
315 SA	2	11	11	505	1095	25	955	1245	390	600	550	115	660	23	6
	4-8	14	12	505	1125	25	955	1275	420	600	550	115	660	23	6
315 SMA	2	11	11	505	1195	25	1055	1345	390	600	550	115	660	23	6
	4-8	14	12	505	1125	25	955	1275	420	600	550	115	660	23	6
315 MB	2	11	11	505	1195	25	1055	1345	390	600	550	115	660	23	6
	4-8	14	12	505	1225	25	1055	1375	420	600	550	115	660	23	6
315 LA	2	11	11	505	1265	25	1125	1415	390	600	550	115	660	23	6
	4-8	14	12	505	1295	25	1125	1445	420	600	550	115	660	23	6
315 LB	2	11	11	505	1545	25	1125	1415	390	600	550	115	660	23	6
	4-8	14	12	505	1575	25	1405	1725	420	600	550	115	660	23	6
315 LC	2	11	11	505	1545	25	1125	1415	390	600	550	115	660	23	6
	4-8	14	12	526	1575	25	1405	1725	420	600	550	115	660	23	6

Tolerances:

D, DA ISO m6

F, FA ISO h9

N ISO j6

- <sup>1)</sup> Dimensions for 4-pole motors also valid for 4/6- and 4-8 -pole two-speed motors.
- <sup>2)</sup> Cooling distance.
- <sup>3)</sup> Second shaft end on request.

Above table gives the main dimensions in mm. For detailed drawings please see our web-pages 'www.abb.com/motors&generators' or contact ABB.

# Industrial performance steel motors

## Dimension drawings

# M2CA 280 - 315

Foot- and flange-mounted; IM B35 (IM 2001), IM V15 (IM 2011), IM V36 (IM 2031) – terminal box top mounted

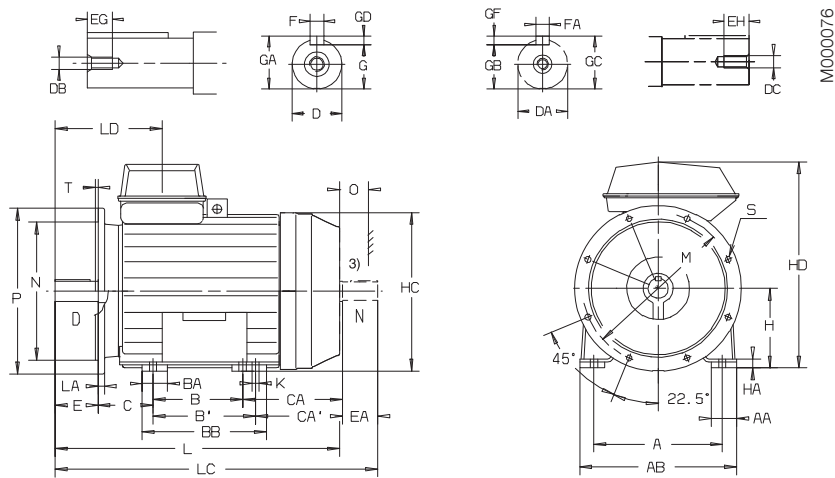

Motor size	Poles <sup>1)</sup>	A	AA	AB	B	B'	BA	BB	C	CA	CA'	D	DA	DB	DC	E	EA	EG	EH	F	FA
		280 SA	2	457	80	545	368	-	100	501	190	372	-	65	60	M20	M20	140	140	40	40
	4-8	457	80	545	368	-	100	501	190	302	-	75	65	M20	M20	140	140	40	40	20	18
280 SMA	2	457	80	545	368	419	100	501	190	372	321	65	60	M20	M20	140	140	40	40	18	18
	4-8	457	80	545	368	419	100	501	190	372	321	75	65	M20	M20	140	140	40	40	20	18
280 MB	2	457	80	545	419	-	100	501	190	381	-	65	60	M20	M20	140	140	40	40	18	18
	4-8	457	80	545	419	-	100	501	190	381	-	75	65	M20	M20	140	140	40	40	20	18
280 MC,MD	2	457	80	545	419	-	100	501	190	381	-	65	60	M20	M20	140	140	40	40	18	18
	4-8	457	80	545	419	-	100	501	190	381	-	75	65	M20	M20	140	140	40	40	20	18
315 SA	2	508	100	622	406	-	100	539	216	343	-	65	60	M20	M20	140	140	40	40	18	18
	4-8	508	100	622	406	-	100	539	216	343	-	80	75	M20	M20	170	140	40	40	22	20
315 SMA	2	508	100	622	406	457	100	539	216	443	392	65	60	M20	M20	140	140	40	40	18	18
	4-8	508	100	622	406	457	100	539	216	343	292	80	75	M20	M20	170	140	40	40	22	20
315 MB	2	508	100	622	457	-	100	539	216	392	-	65	60	M20	M20	140	140	40	40	18	18
	4-8	508	100	622	457	-	100	539	216	392	-	80	75	M20	M20	170	140	40	40	22	20
315 LA	2	508	100	622	508	-	100	592	216	411	-	65	60	M20	M20	140	140	40	40	18	18
	4-8	508	100	622	508	-	100	592	216	411	-	90	75	M24	M20	170	140	48	40	25	20
315 LB,LC	2	508	100	622	508	-	100	592	216	411	-	65	60	M20	M20	140	140	40	40	18	18
	4-8	508	100	622	508	-	100	592	216	411	-	90	75	M24	M20	170	140	48	40	25	20

Motor size	Poles <sup>1)</sup>	G	GA	GB	GC	GD	GF	H	HA	HC	HD	K	L	LA	LC	LD	M	N	O <sup>2)</sup>	P	S	T
		280 SA	2	58	69	53	64	11	11	280	32	558	730	24	1060	22	1210	385	500	450	100	550
	4-8	67.5	79.5	58	69	12	11	280	32	558	730	24	990	22	1140	385	500	450	100	550	18	5
280 SMA	2	58	69	53	64	11	11	280	32	558	730	24	1060	22	1210	385	500	450	100	550	18	5
	4-8	67.5	79.5	58	69	12	11	280	32	558	730	24	1060	22	1210	385	500	450	100	550	18	5
280 MB	2	58	69	53	64	11	11	280	32	558	730	24	1120	22	1270	385	500	450	100	550	18	5
	4-8	67.5	79.5	58	69	12	11	280	32	558	730	24	1120	22	1270	385	500	450	100	550	18	5
280 MC	2	58	69	53	64	11	11	280	32	558	730	24	1255	22	1405	385	500	450	100	550	18	5
	4-8	67.5	79.5	58	69	12	11	280	32	558	730	24	1225	22	1405	385	500	450	100	550	18	5
280 MD	2	58	69	53	64	11	11	280	32	558	730	24	1255	22	1405	385	500	450	100	550	18	5
	4-8	67.5	79.5	58	69	12	11	280	32	558	730	24	1255	22	1405	385	500	450	100	550	18	5
315 SA	2	58	69	53	64	11	11	315	32	627	820	28	1095	25	1245	390	600	550	115	660	23	6
	4-8	71	85	67.5	79.5	14	12	315	32	627	820	28	1125	25	1275	420	600	550	115	660	23	6
315 SMA	2	58	69	53	64	11	11	315	32	627	820	28	1195	25	1345	390	600	550	115	660	23	6
	4-8	71	85	67.5	79.5	14	12	315	32	627	820	28	1125	25	1275	420	600	550	115	660	23	6
315 MB	2	58	69	53	64	11	11	315	32	627	820	28	1195	25	1345	390	600	550	115	660	23	6
	4-8	71	85	67.5	79.5	14	12	315	32	627	820	28	1225	25	1375	420	600	550	115	660	23	6
315 LA	2	58	69	53	64	11	11	315	32	627	820	28	1265	25	1415	390	600	550	115	660	23	6
	4-8	81	95	67.5	79.5	14	12	315	32	627	820	28	1295	25	1445	420	600	550	115	660	23	6
315 LB	2	58	69	53	64	11	11	315	32	627	820	28	1545	25	1695	390	600	550	115	660	23	6
	4-8	81	95	67.5	79.5	14	12	315	32	627	820	28	1575	25	1725	420	600	550	115	660	23	6
315 LC	2	58	69	53	64	11	11	315	32	627	848	28	1545	25	1695	390	600	550	115	660	23	6
	4	81	95	67.5	79.5	14	12	315	32	627	848	28	1575	25	1725	420	600	550	115	660	23	6

Tolerances:

A, B ISO js14      H ISO 0, -1.0

D, DA ISO m6      N ISO j6

F, FA ISO h9

<sup>1)</sup> Dimensions for 4-pole motors also valid for 4/6- and 4-8 -pole two-speed motors.

<sup>2)</sup> Cooling distance.

<sup>3)</sup> Second shaft end on request.

Above table gives the main dimensions in mm. For detailed drawings please see our web-pages 'www.abb.com/motors&generators' or contact ABB.

# Industrial performance steel motors

## Dimension drawings

# M2CA 280 - 315

Foot- and flange-mounted; IM B35 (IM 2001), IM V15 (IM 2011), IM V36 (IM 2031) – terminal box side mounted

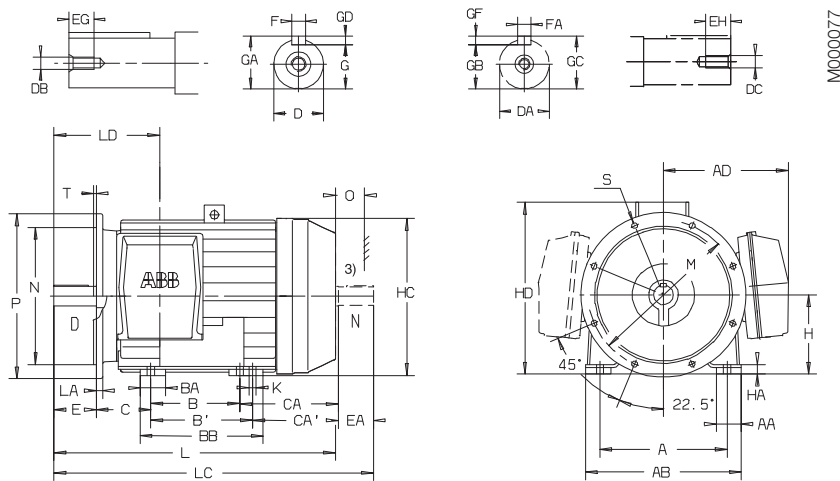

Motor size	Poles <sup>1)</sup>	Dimensions (mm)																				
		A	AA	AB	AD	B	B'	BA	BB	C	CA	CA'	D	DA	DB	DC	E	EA	EG	EH	F	FA
280 SA	2	457	80	545	448	368	–	100	501	190	372	–	65	60	M20	M20	140	140	40	40	18	18
	4-8	457	80	545	448	368	–	100	501	190	302	–	75	65	M20	M20	140	140	40	40	20	18
280 SMA	2	457	80	545	448	368	419	100	501	190	372	321	65	60	M20	M20	140	140	40	40	18	18
	4-8	457	80	545	448	368	419	100	501	190	372	321	75	65	M20	M20	140	140	40	40	20	18
280 MB	2	457	80	545	448	419	–	100	501	190	381	–	65	60	M20	M20	140	140	40	40	18	18
	4-8	457	80	545	448	419	–	100	501	190	381	–	75	65	M20	M20	140	140	40	40	20	18
280 MC,MD	2	457	80	545	448	419	–	100	501	190	381	–	65	60	M20	M20	140	140	40	40	18	18
	4-8	457	80	545	448	419	–	100	501	190	381	–	75	65	M20	M20	140	140	40	40	20	18
315 SA	2	508	100	622	502	406	–	100	539	216	343	–	65	60	M20	M20	170	140	40	40	18	18
	4-8	508	100	622	502	406	–	100	539	216	343	–	80	75	M20	M20	170	140	40	40	22	20
315 SMA	2	508	100	622	502	406	457	100	539	216	443	392	65	60	M20	M20	140	140	40	40	18	18
	4-8	508	100	622	502	406	457	100	539	216	343	292	80	75	M20	M20	170	140	40	40	22	20
315 MB	2	508	100	622	502	457	–	100	539	216	392	–	65	60	M20	M20	140	140	40	40	18	18
	4-8	508	100	622	502	457	–	100	539	216	392	–	80	75	M20	M20	170	140	40	40	22	20
315 LA	2	508	100	622	502	508	–	100	592	216	411	–	65	60	M20	M20	140	140	40	40	18	18
	4-8	508	100	622	502	508	–	100	592	216	411	–	90	75	M24	M20	170	140	48	40	25	20
315 LB,LC	2	508	100	622	502	508	–	100	592	216	411	–	65	60	M20	M20	140	140	40	40	18	18
	4-8	508	100	622	502	508	–	100	592	216	411	–	90	75	M24	M20	170	140	48	40	25	20

Motor size	Poles <sup>1)</sup>	Dimensions (mm)																	O <sup>2)</sup>		
		G	GA	GB	GC	GD	GF	H	HA	HC	HD	K	L	LC	LD	M	N	P	S	T	
280 SA	2	58	69	53	64	11	11	280	32	558	620	24	1060	1210	385	500	450	100	550	18	5
	4-8	67.5	79.5	58	69	12	11	280	32	558	620	24	990	1140	385	500	450	100	550	18	5
280 SMA	2	58	69	53	64	11	11	280	32	558	620	24	1060	1210	385	500	450	100	550	18	5
	4-8	67.5	79.5	58	69	12	11	280	32	558	620	24	1060	1210	385	500	450	100	550	18	5
280 MB	2	58	69	53	64	11	11	280	32	558	620	24	1120	1270	385	500	450	100	550	18	5
	4-8	67.5	79.5	58	69	12	11	280	32	558	620	24	1120	1270	385	500	450	100	550	18	5
280 MC	2	58	69	53	64	11	11	280	32	558	620	24	1255	1405	385	500	450	100	550	18	5
	4-8	67.5	79.5	58	69	12	11	280	32	558	620	24	1255	1405	385	500	450	100	550	18	5
280 MD	2	58	69	53	64	11	11	280	32	558	620	24	1255	1405	385	500	450	100	550	18	5
	4-8	67.5	79.5	58	69	12	11	280	32	558	620	24	1255	1405	385	500	450	100	550	18	5
315 SA	2	58	69	53	64	11	11	315	32	627	685	28	1095	1245	390	600	550	115	660	23	6
	4-8	71	85	67.5	79.5	14	12	315	32	627	685	28	1125	1275	420	600	550	115	660	23	6
315 SMA	2	58	69	53	64	11	11	315	32	627	685	28	1195	1345	390	600	550	115	660	23	6
	4-8	71	85	67.5	79.5	14	12	315	32	627	685	28	1125	1275	420	600	550	115	660	23	6
315 MB	2	58	69	53	64	11	11	315	32	627	685	28	1195	1345	390	600	550	115	660	23	6
	4-8	71	85	67.5	79.5	14	12	315	32	627	685	28	1225	1375	420	600	550	115	660	23	6
315 LA	2	58	69	53	64	11	11	315	32	627	685	28	1265	1415	390	600	550	115	660	23	6
	4-8	81	95	67.5	79.5	14	12	315	32	627	685	28	1295	1445	420	600	550	115	660	23	6
315 LB,LC	2	58	69	53	64	11	11	315	32	627	685	28	1545	1695	390	600	550	115	660	23	6
	4-8	81	95	67.5	79.5	14	12	315	32	627	685	28	1575	1725	420	600	550	115	660	23	6

Tolerances:

A, B	ISO js14	H	ISO 0, -1.0
D, DA	ISO m6	N	ISO j6
F, FA	ISO h9		

- <sup>1)</sup> Dimensions for 4-pole motors also valid for 4/6- and 4-8 -pole two-speed motors.  
<sup>2)</sup> Cooling distance.  
<sup>3)</sup> Second shaft end on request.

**Above table gives the main dimensions in mm. For detailed drawings please see our web-pages 'www.abb.com/motors&generators' or contact ABB.**

# Industrial performance steel motors

## Dimension drawings

# M2CA 355 - 400

Foot-mounted; IM B3 (IM 1001), IM B6 (IM 1051), IM B7 (IM 1061), IM B8 (IM 1071), IM V5 (IM 1011), IM V6 (IM 1031) – terminal box top mounted

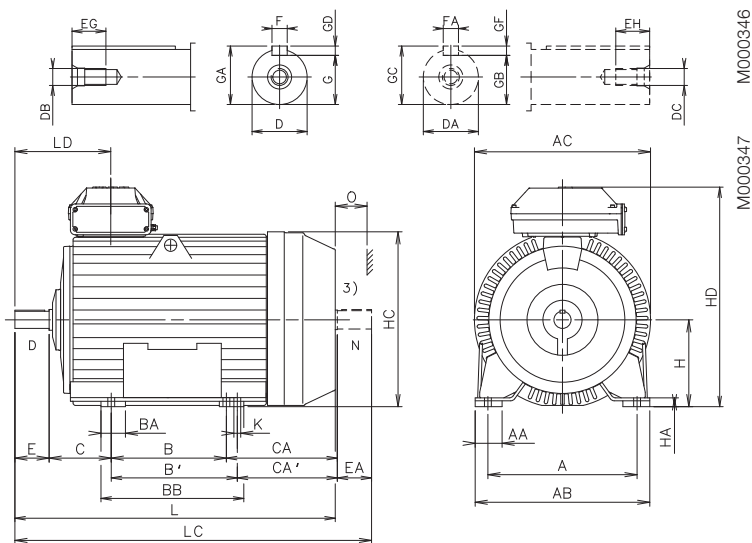

Motor size	Poles <sup>1)</sup>	A	AA	AB	AC	B	B'	BA	BB	C	CA	CA'	D	DA	DB	DC	E	EA	EG	EH
355 SA,SB	2	610	110	714	720	500	-	100	584	254	423	-	70	70	M20	M20	140	140	40	40
	4-8	610	110	714	720	500	-	100	584	254	423	-	100	90	M24	M20	210	170	48	48
355 MA	2	610	110	714	720	560	-	100	644	254	423	-	70	70	M20	M20	140	140	40	40
	4-8	610	110	714	720	560	-	100	644	254	423	-	100	90	M24	M24	210	170	48	48
355 MB	2	610	110	714	720	560	-	100	644	254	423	-	70	70	M20	M20	140	140	40	40
	4-8	610	110	714	720	560	-	100	644	254	423	-	100	90	M24	M24	210	170	48	48
355 LA	2	610	110	714	720	630	-	100	714	254	433	-	70	70	M20	M20	140	140	40	40
	4-8	610	110	714	720	630	-	100	714	254	433	-	100	90	M24	M24	210	170	48	48
355 LB	2	610	110	714	720	630	-	100	714	254	433	-	70	70	M20	M20	140	140	40	40
	4-8	610	110	714	720	630	-	100	714	254	433	-	100	90	M24	M24	210	170	48	48
355 LKD	4-8	610	110	714	720	630	710	100	802	254	590	510	100	90	M24	M24	210	170	48	48
400 MLA	2	686	140	820	810	630	710	140	850	280	595	515	70	70	M20	M20	140	140	40	40
	4-8	686	140	820	810	630	710	140	850	280	595	515	100	90	M24	M24	210	170	48	48
400 MLB	2	686	140	820	810	630	710	140	850	280	595	515	70	70	M20	M20	140	140	40	40
	4-8	686	140	820	810	630	710	140	850	280	595	515	100	90	M24	M24	210	170	48	48
400 LKA	2	686	140	820	810	710	800	140	935	280	655	565	80	75	M20	M20	170	140	40	40
	4-8	686	140	820	810	710	800	140	935	280	655	565	100	90	M24	M24	210	170	48	48
400 LKB	2	686	140	820	810	710	800	140	935	280	655	565	80	75	M20	M20	170	140	40	40
	4-8	686	140	820	810	710	800	140	935	280	655	565	100	90	M24	M24	210	170	48	48

Motor size	Poles <sup>1)</sup>	F	FA	G	GA	GB	GC	GD	GF	H	HA	HC	HD <sup>4)</sup>	HD <sup>5)</sup>	K	L	LC	LD	O <sup>2)</sup>
355 SA,SB	2	20	20	62.5	74.5	62.5	74.5	12	12	355	36	715	900		28	1317	1467	392	130
	4-8	28	25	90	106	81	95	16	14	355	36	715	900		28	1387	1567	462	130
355 MA	2	20	20	62.5	74.5	62.5	74.5	12	12	355	36	715	900	915	28	1377	1527	392	130
	4-8	28	25	90	106	81	95	16	14	355	36	715	900	915	28	1447	1627	462	130
355 MB	2	20	20	62.5	74.5	62.5	74.5	12	12	355	36	715	900	915	28	1377	1527	392	130
	4-8	28	25	90	106	81	95	16	14	355	36	715	900	915	28	1447	1627	462	130
355 LA	2	20	20	62.5	74.5	62.5	74.5	12	12	355	36	715		915	28	1457	1607	392	130
	4-8	28	25	90	106	81	95	16	14	355	36	715		915	28	1527	1707	462	130
355 LB	2	20	20	62.5	74.5	62.5	74.5	12	12	355	36	715		915	28	1457	1607	392	130
	4-8	28	25	90	106	81	95	16	14	355	36	715		915	28	1527	1707	462	130
355 LKD	4-8	28	25	90	106	91	95	16	14	355	36	715		915	28	1667	1854	462	130
400 MLA	2	20	20	62.5	74.5	62.5	74.5	12	12	400	45	805		1000	35	1628	1785	408	150
	4-8	28	25	90	106	81	95	16	14	400	45	805		1000	35	1698	1885	478	150
400 MLB	2	20	20	62.5	74.5	62.5	74.5	12	12	400	45	805		1000	35	1628	1785	408	150
	4-8	28	25	90	106	81	95	16	14	400	45	805		1000	35	1698	1885	478	150
400 LKA	2	22	20	71	85	67.5	79.5	14	12	400	45	805		1000	35	1798	1955	438	150
	4-8	28	25	90	106	81	95	16	14	400	45	805		1000	35	1838	2025	478	150
400 LKB	2	22	20	71	85	67.5	79.5	14	12	400	45	805		1000	35	1798	1955	438	150
	4-8	28	25	90	106	81	95	16	14	400	45	805		1000	35	1838	2025	478	150

Tolerances:

A, B	ISO js14	H	ISO 0, -1.0
D, DA	ISO m6		
F, FA	ISO h9		

- 1) Dimensions for 4-pole motors also valid for 4/6- and 4-8 -pole two-speed motors.
- 2) Cooling distance.
- 3) Second shaft end on request.
- 4) Terminal box 370
- 5) Terminal box 750

Above table gives the main dimensions in mm. For detailed drawings please see our web-pages '[www.abb.com/motors&generators](http://www.abb.com/motors&generators)' or contact ABB.

# Industrial performance steel motors Dimension drawings

## M2CA 355 - 400

Foot-mounted; IM B3 (IM 1001), IM B6 (IM 1051), IM B7 (IM 1061), IM B8 (IM 1071),  
IM V5 (IM 1011), IM V6 (IM 1031) – terminal box side mounted

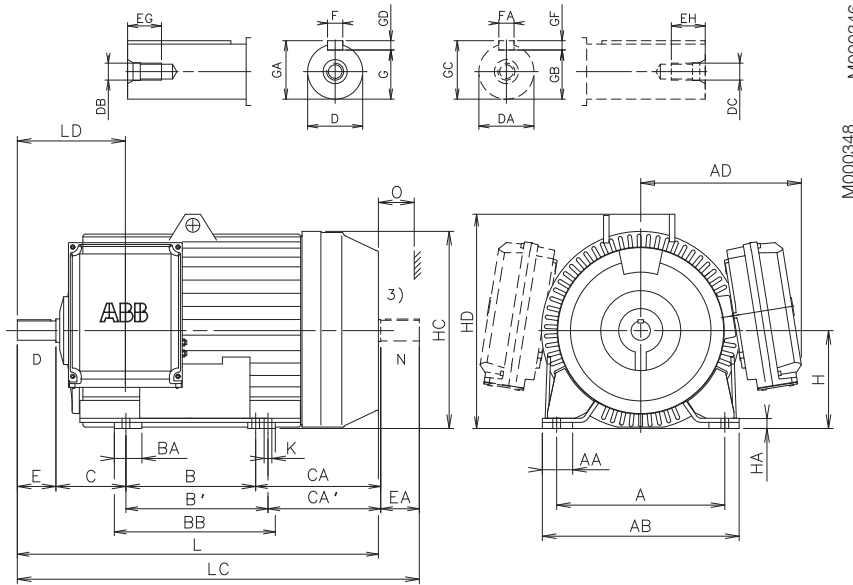

Motor size	Poles <sup>1)</sup>																			
		A	AA	AB	AD 4)	B	B'	BA	BB	C	CA	CA'	D	DA	DB	DC	E	EA	EG	EH
355 SA,SB	2	610	110	714	583	500	–	100	584	254	423	–	70	70	M20	M20	140	140	40	40
	4-8	610	110	714	583	500	–	100	584	254	423	–	100	90	M24	M20	210	170	48	48
355 MA	2	610	110	714	583	560	–	100	644	254	423	–	70	70	M20	M20	140	140	40	40
	4-8	610	110	714	583	560	–	100	644	254	423	–	100	90	M24	M24	210	170	48	48
355 MB	2	610	110	714	583	560	–	100	644	254	423	–	70	70	M20	M20	140	140	40	40
	4-8	610	110	714	583	560	–	100	644	254	423	–	100	90	M24	M24	210	170	48	48
355 LA	2	610	110	714	583	630	–	100	714	254	433	–	70	70	M20	M20	140	140	40	40
	4-8	610	110	714	583	630	–	100	714	254	433	–	100	90	M24	M24	210	170	48	48
355 LB	2	610	110	714	583	630	–	100	714	254	433	–	70	70	M20	M20	140	140	40	40
	4-8	610	110	714	583	630	–	100	714	254	433	–	100	90	M24	M24	210	170	48	48
355 LKD	4-8	610	110	714	583	630	710	100	802	254	590	510	100	90	M24	M24	210	170	48	48
400 MLA	2	686	140	820	615	630	710	140	850	280	595	515	70	70	M20	M20	140	140	40	40
	4-8	686	140	820	615	630	710	140	850	280	595	515	100	90	M24	M24	210	170	48	48
400 MLB	2	686	140	820	615	630	710	140	850	280	595	515	70	70	M20	M20	140	140	40	40
	4-8	686	140	820	615	630	710	140	850	280	595	515	100	90	M24	M24	210	170	48	48
400 LKA	2	686	140	820	615	710	800	140	935	280	655	565	80	75	M20	M20	170	140	40	40
	4-8	686	140	820	615	710	800	140	935	280	655	565	100	90	M24	M24	210	170	48	48
400 LKB	2	686	140	820	615	710	800	140	935	280	655	565	80	75	M20	M20	170	140	40	40
	4-8	686	140	820	615	710	800	140	935	280	655	565	100	90	M24	M24	210	170	48	48

Motor size	Poles <sup>1)</sup>																		O <sup>2)</sup>
		F	FA	G	GA	GB	GC	GD	GF	H	HA	HC	HD	K	L	LC	LD		
355 SA,SB	2	20	20	62.5	74.5	62.5	74.5	12	12	355	36	715	777	28	1317	1467	392	130	
	4-8	28	25	90	106	81	95	16	14	355	36	715	777	28	1387	1567	462	130	
355 MA	2	20	20	62.5	74.5	62.5	74.5	12	12	355	36	715	777	28	1377	1527	392	130	
	4-8	28	25	90	106	81	95	16	14	355	36	715	777	28	1447	1627	462	130	
355 MB	2	20	20	62.5	74.5	62.5	74.5	12	12	355	36	715	777	28	1377	1527	392	130	
	4-8	28	25	90	106	81	95	16	14	355	36	715	777	28	1447	1627	462	130	
355 LA	2	20	20	62.5	74.5	62.5	74.5	12	12	355	36	715	777	28	1457	1607	392	130	
	4-8	28	25	90	106	81	95	16	14	355	36	715	777	28	1527	1707	462	130	
355 LB	2	20	20	62.5	74.5	62.5	74.5	12	12	355	36	715	777	28	1457	1607	392	130	
	4-8	28	25	90	106	81	95	16	14	355	36	715	777	28	1527	1707	462	130	
355 LKD	4-8	28	25	90	106	91	95	16	14	355	36	715	777	28	1667	1854	462	130	
400 MLA	2	20	20	62.5	74.5	62.5	74.5	12	12	400	45	805	862	35	1628	1785	408	150	
	4-8	28	25	90	106	81	95	16	14	400	45	805	862	35	1698	1885	478	150	
400 MLB	2	20	20	62.5	74.5	62.5	74.5	12	12	400	45	805	862	35	1628	1785	408	150	
	4-8	28	25	90	106	81	95	16	14	400	45	805	862	35	1698	1885	478	150	
400 LKA	2	22	20	71	85	67.5	79.5	14	12	400	45	805	862	35	1798	1955	438	150	
	4-8	28	25	90	106	81	95	16	14	400	45	805	862	35	1838	2025	478	150	
400 LKB	2	22	20	71	85	67.5	79.5	14	12	400	45	805	862	35	1798	1955	438	150	
	4-8	28	25	90	106	81	95	16	14	400	45	805	862	35	1838	2025	478	150	

Tolerances:

A, B ISO js14      H      ISO 0, -1.0  
D, DA ISO m6  
F, FA ISO h9

- <sup>1)</sup> Dimensions for 4-pole motors also valid for 4/6- and 4-8 -pole two-speed motors.
- <sup>2)</sup> Cooling distance.
- <sup>3)</sup> Second shaft end on request.
- <sup>4)</sup> Terminal box 750

Above table gives the main dimensions in mm. For detailed drawings please see our web-pages '[www.abb.com/motors&generators](http://www.abb.com/motors&generators)' or contact ABB.

# Industrial performance steel motors

## Dimension drawings

# M2CA 355 - 400

Flange-mounted; IM B5 (IM 3001), V1 (IM 3011), V3 (IM 3031) and IM B14 (IM 3601), V18 (IM 3611), V19 (IM 3631)

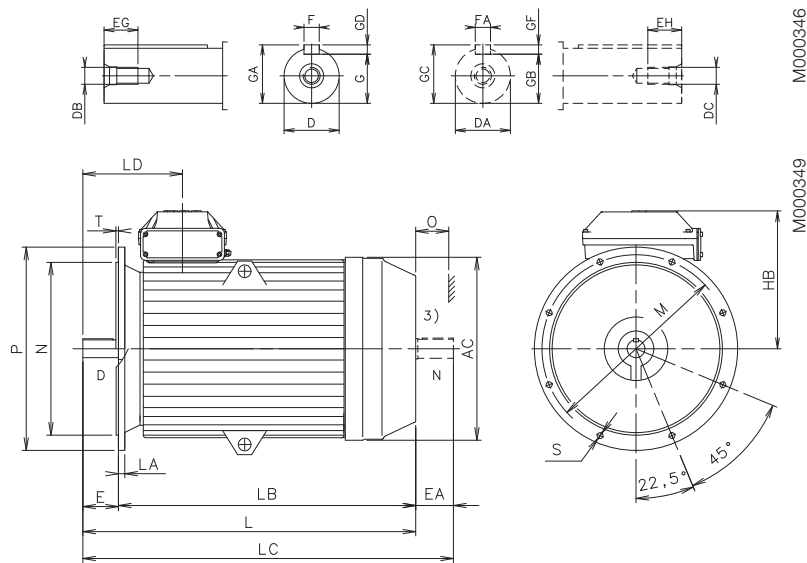

Motor size	Poles <sup>1)</sup>	AC	D	DA	DB	DC	E	EA	EG	EH	F	FA	G	GA	GB	GC
355 SA,SB	2	720	70	70	M20	M20	140	140	40	40	20	20	62.5	74.5	62.5	74.5
	4-8	720	100	90	M24	M24	210	170	48	48	28	25	90	106	81	95
355 MA	2	720	70	70	M20	M20	140	140	40	40	20	20	62.5	74.5	62.5	74.5
	4-8	720	100	90	M24	M24	210	170	48	48	28	25	90	106	81	95
355 MB	2	720	70	70	M20	M20	140	140	40	40	20	20	62.5	74.5	62.5	74.5
	4-8	720	100	90	M24	M24	210	170	48	48	28	25	90	106	81	95
355 LA	2	720	70	70	M20	M20	140	140	40	40	20	20	62.5	74.5	62.5	74.5
	4-8	720	100	90	M24	M24	210	170	48	48	28	25	90	106	81	95
355 LB	2	720	70	70	M20	M20	140	140	40	40	20	20	62.5	74.5	62.5	74.5
	4-8	720	100	90	M24	M24	210	170	48	48	28	25	90	106	81	95
355 LKD	4-8	720	100	90	M24	M24	210	170	48	48	28	25	90	106	81	95
400 MLA	2	810	70	70	M20	M20	140	140	40	40	20	20	62.5	74.5	62.5	74.5
	4-8	810	100	90	M24	M24	210	170	48	48	28	25	90	106	81	95
400 MLB	2	810	70	70	M20	M20	140	140	40	40	20	20	62.5	74.5	62.5	74.5
	4-8	810	100	90	M24	M24	210	170	48	48	28	25	90	106	81	95
400 LKA	2	810	80	75	M20	M20	170	140	40	40	22	20	71	85	67.5	79.5
	4-8	810	100	90	M24	M24	210	170	48	48	28	25	90	106	81	95
400 LKB	2	810	80	75	M20	M20	170	140	40	40	22	20	71	85	67.5	79.5
	4-8	810	100	90	M24	M24	210	170	48	48	28	25	90	106	81	95

Motor size	Poles <sup>1)</sup>	GD	GF	HB <sup>4)</sup>	HB <sup>5)</sup>	L	LA	LB	LC	LD	M	N	O <sup>2)</sup>	P	S	T
355 SA,SB	2	12	12	545		1317	25	1177	1467	392	740	680	130	800	23	6
	4-8	16	14	545		1387	25	1177	1567	462	740	680	130	800	23	6
355 MA	2	12	12	545	560	1377	25	1237	1527	392	740	680	130	800	23	6
	4-8	16	14	545	560	1447	25	1237	1627	462	740	680	130	800	23	6
355 MB	2	12	12	545	560	1377	25	1237	1527	392	740	680	130	800	23	6
	4-8	16	14	545	560	1447	25	1237	1627	462	740	680	130	800	23	6
355 LA	2	12	12		560	1457	25	1317	1607	392	740	680	130	800	23	6
	4-8	16	14		560	1527	25	1317	1707	462	740	680	130	800	23	6
355 LB	2	12	12		560	1457	25	1317	1607	392	740	680	130	800	23	6
	4-8	16	14		560	1527	25	1317	1707	462	740	680	130	800	23	6
355 LKD	4-8	16	14		560	1667	25	1457	1854	462	740	680	130	800	23	6
400 MLA	2	12	12		600	1628	25	1488	1785	408	740	680	150	800	23	6
	4-8	16	14		600	1698	25	1488	1885	478	740	680	150	800	23	6
400 MLB	2	12	12		600	1628	25	1488	1785	408	740	680	150	800	23	6
	4-8	16	14		600	1698	25	1488	1885	478	740	680	150	800	23	6
400 LKA	2	14	12		600	1798	25	1628	1955	438	740	680	150	800	23	6
	4-8	16	14		600	1838	25	1628	2025	478	740	680	150	800	23	6
400 LKB	2	14	12		600	1798	25	1628	1955	438	740	680	150	800	23	6
	4-8	16	14		600	1838	25	1628	2025	478	740	680	150	800	23	6

Tolerances:

D, DA ISO m6  
F, FA ISO h9  
N ISO j6

- 1) Dimensions for 4-pole motors also valid for 4/6- and 4-8 -pole two-speed motors.
- 2) Cooling distance.
- 3) Second shaft end on request.
- 4) Terminal box 350
- 5) Terminal box 750

Above table gives the main dimensions in mm. For detailed drawings please see our web-pages [www.abb.com/motors&generators](http://www.abb.com/motors&generators) or contact ABB.

# Industrial performance steel motors

## Dimension drawings

# M2CA 355 - 400

Foot- and flange-mounted; IM B35 (IM 2001), IM V15 (IM 2011), IM V36 (IM 2031) – terminal box top mounted

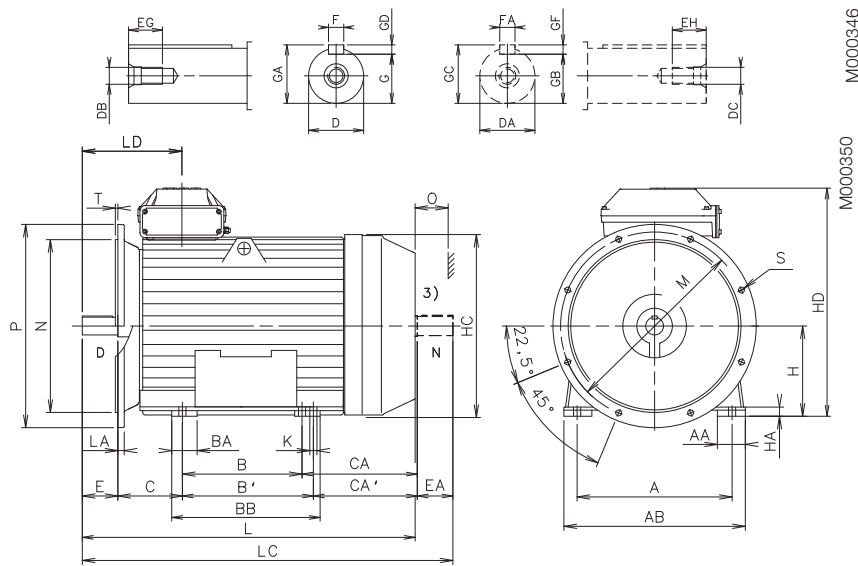

M000346  
M000350

Motor size	Poles <sup>1)</sup>	Dimensions (mm)																			
		A	AA	AB	B	B'	BA	BB	C	CA	CA'	D	DA	DB	DC	E	EA	EG	EH	F	FA
355 SA,SB	2	610	110	714	500	–	100	584	254	433	–	70	70	M20	M20	140	140	40	40	20	20
	4-8	610	110	714	500	–	100	584	254	433	–	100	90	M24	M20	210	170	48	48	28	25
355 MA	2	610	110	714	560	–	100	644	254	433	–	70	70	M20	M20	140	140	40	40	20	20
	4-8	610	110	714	560	–	100	644	254	433	–	100	90	M24	M24	210	170	48	48	28	25
355 MB	2	610	110	714	560	–	100	644	254	433	–	70	70	M20	M20	140	140	40	40	20	20
	4-8	610	110	714	560	–	100	644	254	433	–	100	90	M24	M24	210	170	48	48	28	25
355 LA	2	610	110	714	630	–	100	714	254	443	–	70	70	M20	M20	140	140	40	40	20	20
	4-8	610	110	714	630	–	100	714	254	443	–	100	90	M24	M24	210	170	48	48	28	25
355 LB	2	610	110	714	630	–	100	714	254	443	–	70	70	M20	M20	140	140	40	40	20	20
	4-8	610	110	714	630	–	100	714	254	443	–	100	90	M24	M24	210	170	48	48	28	25
355 LKD	4-8	610	110	714	630	710	100	802	254	590	510	100	90	M24	M24	210	170	48	48	28	25
	2	686	140	820	630	710	140	850	280	595	515	70	70	M20	M20	140	140	40	40	20	20
400 MLA	2	686	140	820	630	710	140	850	280	595	515	70	70	M20	M20	140	140	40	40	20	20
	4-8	686	140	820	630	710	140	850	280	595	515	100	90	M24	M24	210	170	48	48	28	25
400 MLB	2	686	140	820	630	710	140	850	280	595	515	70	70	M20	M20	140	140	40	40	20	20
	4-8	686	140	820	630	710	140	850	280	595	515	100	90	M24	M24	210	170	48	48	28	25
400 LKA	2	686	140	820	710	800	140	935	280	655	565	80	75	M20	M20	170	140	40	40	22	20
	4-8	686	140	820	710	800	140	935	280	655	565	100	90	M24	M24	210	170	48	48	28	25
400 LKB	2	686	140	820	710	800	140	935	280	655	565	80	75	M20	M20	170	140	40	40	22	20
	4-8	686	140	820	710	800	140	935	280	655	565	100	90	M24	M24	210	170	48	48	28	25

Motor size	Poles <sup>1)</sup>	Dimensions (mm)																				
		G	GA	GB	GC	GD	GF	H	HA	HC	HD <sup>4)</sup>	HD <sup>5)</sup>	K	L	LC	LD	M	N	O <sup>2)</sup>	P	S	T
355 SA,SB	2	62.5	74.5	62.5	74.5	12	12	355	36	715	900	–	28	1317	1467	392	740	680	130	800	23	6
	4-8	90	106	81	95	16	14	355	36	715	900	915	28	1387	1567	462	740	680	130	800	23	6
355 MA	2	62.5	74.5	62.5	74.5	12	12	355	36	715	900	915	28	1377	1527	392	740	680	130	800	23	6
	4-8	90	106	81	95	16	14	355	36	715	900	915	28	1447	1627	462	740	680	130	800	23	6
355 MB	2	62.5	74.5	62.5	74.5	12	12	355	36	715	900	915	28	1377	1527	392	740	680	130	800	23	6
	4-8	90	106	81	95	16	14	355	36	715	900	915	28	1447	1627	462	740	680	130	800	23	6
355 LA	2	62.5	74.5	62.5	74.5	12	12	355	36	715	900	915	28	1457	1607	392	740	680	130	800	23	6
	4-8	90	106	81	95	16	14	355	36	715	900	915	28	1527	1707	462	740	680	130	800	23	6
355 LB	2	62.5	74.5	62.5	74.5	12	12	355	36	715	900	915	28	1457	1607	392	740	680	130	800	23	6
	4-8	90	106	81	95	16	14	355	36	715	900	915	28	1527	1707	462	740	680	130	800	23	6
355 LKD	4-8	90	106	91	95	16	14	355	36	715	900	915	28	1667	1854	462	740	680	130	800	23	6
	2	62.5	74.5	62.5	74.5	12	12	400	45	805	1000	35	–	1628	1785	408	740	680	150	800	23	6
400 MLA	2	62.5	74.5	62.5	74.5	12	12	400	45	805	1000	35	–	1698	1885	478	740	680	150	800	23	6
	4-8	90	106	81	95	16	14	400	45	805	1000	35	–	1628	1785	408	740	680	150	800	23	6
400 MLB	2	62.5	74.5	62.5	74.5	12	12	400	45	805	1000	35	–	1698	1885	478	740	680	150	800	23	6
	4-8	90	106	81	95	16	14	400	45	805	1000	35	–	1628	1785	408	740	680	150	800	23	6
400 LKA	2	71	85	67.5	79.5	14	12	400	45	805	1000	35	–	1798	1955	438	740	680	150	800	23	6
	4-8	90	106	81	95	16	14	400	45	805	1000	35	–	1838	2025	478	740	680	150	800	23	6
400 LKB	2	71	85	67.5	79.5	14	12	400	45	805	1000	35	–	1798	1955	438	740	680	150	800	23	6
	4-8	90	106	81	95	16	14	400	45	805	1000	35	–	1838	2025	478	740	680	150	800	23	6

Tolerances:

A, B	ISO js14	H	ISO 0, -1.0
D, DA	ISO m6	N	ISO j6
F, FA	ISO h9		

- Dimensions for 4-pole motors also valid for 4/6- and 4-8-pole two-speed motors.
- Cooling distance.
- Second shaft end on request.
- Terminal box 370
- Terminal box 750

**Above table gives the main dimensions in mm. For detailed drawings please see our web-pages 'www.abb.com/motors&generators' or contact ABB.**



# Industrial performance steel motors

## Dimension drawings

# M2CA 355 - 400

Foot- and flange-mounted; IM B35 (IM 2001), IM V15 (IM 2011), IM V36 (IM 2031) – terminal box side mounted

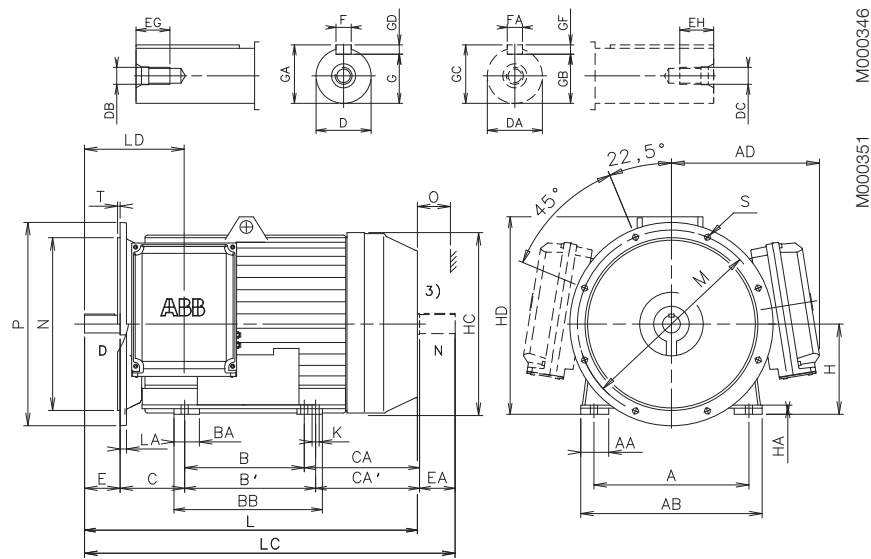

Motor size	Poles <sup>1)</sup>	A	AA	AB	AD <sup>4)</sup>	B	B'	BA	BB	C	CA	CA'	D	DA	DB	DC	E	EA	EG	EH	F	FA
355 SA,SB	2	610	110	714	583	500	–	100	584	254	423	–	70	70	M20	M20	140	140	40	40	20	20
	4-8	610	110	714	583	500	–	100	584	254	423	–	100	90	M24	M20	210	170	48	48	28	25
355 MA	2	610	110	714	583	560	–	100	644	254	423	–	70	70	M20	M20	140	140	40	40	20	20
	4-8	610	110	714	583	560	–	100	644	254	423	–	100	90	M24	M24	210	170	48	48	28	25
355 MB	2	610	110	714	583	560	–	100	644	254	423	–	70	70	M20	M20	140	140	40	40	20	20
	4-8	610	110	714	583	560	–	100	644	254	423	–	100	90	M24	M24	210	170	48	48	28	25
355 LA	2	610	110	714	583	630	–	100	714	254	433	–	70	70	M20	M20	140	140	40	40	20	20
	4-8	610	110	714	583	630	–	100	714	254	433	–	100	90	M24	M24	210	170	48	48	28	25
355 LB	2	610	110	714	583	630	–	100	714	254	433	–	70	70	M20	M20	140	140	40	40	20	20
	4-8	610	110	714	583	630	–	100	714	254	433	–	100	90	M24	M24	210	170	48	48	28	25
355 LKD	4-8	610	110	714	583	630	710	100	802	254	590	510	100	90	M24	M24	210	170	48	48	28	25
400 MLA	2	686	140	820	615	630	710	140	850	280	595	515	70	70	M20	M20	140	140	40	40	20	20
	4-8	686	140	820	615	630	710	140	850	280	595	515	100	90	M24	M24	210	170	48	48	28	25
400 MLB	2	686	140	820	615	630	710	140	850	280	595	515	70	70	M20	M20	140	140	40	40	20	20
	4-8	686	140	820	615	630	710	140	850	280	595	515	100	90	M24	M24	210	170	48	48	28	25
400 LKA	2	686	140	820	615	710	800	140	935	280	655	565	80	75	M20	M20	170	140	40	40	22	20
	4-8	686	140	820	615	710	800	140	935	280	655	565	100	90	M24	M24	210	170	48	48	28	25
400 LKB	2	686	140	820	615	710	800	140	935	280	655	565	80	75	M20	M20	170	140	40	40	22	20
	4-8	686	140	820	615	710	800	140	935	280	655	565	100	90	M24	M24	210	170	48	48	28	25

Motor size	Poles <sup>1)</sup>	G	GA	GB	GC	GD	GF	H	HA	HC	HD	K	L	LC	LD	M	N	O <sup>2)</sup>	P	S	T
355 SA,SB	2	62.5	74.5	62.5	74.5	12	12	355	36	715	777	28	1317	1467	392	740	680	130	800	23	6
	4-8	90	106	81	95	16	14	355	36	715	777	28	1387	1567	462	740	680	130	800	23	6
355 MA	2	62.5	74.5	62.5	74.5	12	12	355	36	715	777	28	1377	1527	392	740	680	130	800	23	6
	4-8	90	106	81	95	16	14	355	36	715	777	28	1447	1627	462	740	680	130	800	23	6
355 MB	2	62.5	74.5	62.5	74.5	12	12	355	36	715	777	28	1377	1527	392	740	680	130	800	23	6
	4-8	90	106	81	95	16	14	355	36	715	777	28	1447	1627	462	740	680	130	800	23	6
355 LA	2	62.5	74.5	62.5	74.5	12	12	355	36	715	777	28	1457	1607	392	740	680	130	800	23	6
	4-8	90	106	81	95	16	14	355	36	715	777	28	1527	1707	462	740	680	130	800	23	6
355 LB	2	62.5	74.5	62.5	74.5	12	12	355	36	715	777	28	1457	1607	392	740	680	130	800	23	6
	4-8	90	106	81	95	16	14	355	36	715	777	28	1527	1707	462	740	680	130	800	23	6
355 LKD	4-8	90	106	81	95	16	14	355	36	715	777	28	1667	1854	462	740	680	130	800	23	6
400 MLA	2	62.5	74.5	62.5	74.5	12	12	400	45	805	862	35	1628	1785	408	740	680	150	800	23	6
	4-8	90	106	81	95	16	14	400	45	805	862	35	1698	1885	478	740	680	150	800	23	6
400 MLB	2	62.5	74.5	62.5	74.5	12	12	400	45	805	862	35	1628	1785	408	740	680	150	800	23	6
	4-8	90	106	81	95	16	14	400	45	805	862	35	1698	1885	478	740	680	150	800	23	6
400 LKA	2	71	85	67.5	79.5	14	12	400	45	805	862	35	1798	1955	438	740	680	150	800	23	6
	4-8	90	106	81	95	16	14	400	45	805	862	35	1838	2025	478	740	680	150	800	23	6
400 LKB	2	71	85	67.5	79.5	14	12	400	45	805	862	35	1798	1955	438	740	680	150	800	23	6
	4-8	90	106	81	95	16	14	400	45	805	862	35	1838	2025	478	740	680	150	800	23	6

Tolerances:

A, B	ISO js14	H	ISO 0, -1.0
D, DA	ISO m6	N	ISO j6
F, FA	ISO h9		

- <sup>1)</sup> Dimensions for 4-pole motors also valid for 4/6- and 4-8 -pole two-speed motors.
- <sup>2)</sup> Cooling distance.
- <sup>3)</sup> Second shaft end on request.
- <sup>4)</sup> Terminal box 750

Above table gives the main dimensions in mm. For detailed drawings please see our web-pages '[www.abb.com/motors&generators](http://www.abb.com/motors&generators)' or contact ABB.

# Accessories

## Slide rails for motor sizes 280 - 400

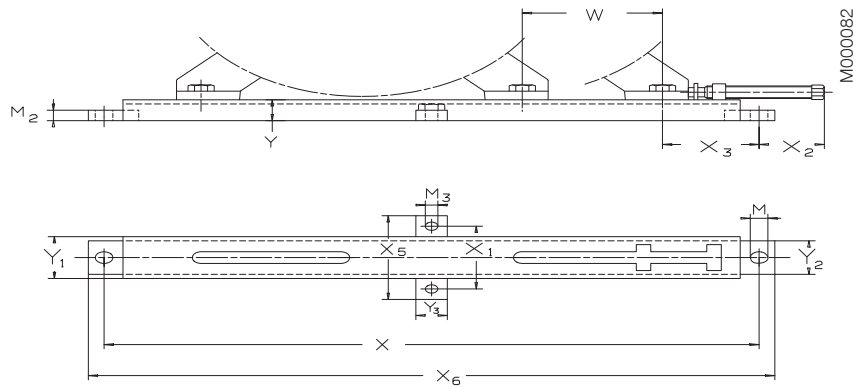

Type	Motor size	M	M <sub>2</sub>	M <sub>3</sub>	W <sub>max</sub>	X	X <sub>1</sub>	X <sub>2</sub> max	X <sub>3</sub> min	X <sub>5</sub>	X <sub>6</sub>	Y	Y <sub>1</sub>	Y <sub>2</sub>	Y <sub>3</sub>	Weight/rail kg
ZHKJ 50	280	28	25	20	135	850	150	125	135	200	900	50	100	80	50	14.5
ZHKJ 63	315	28	25	20	220	1040	150	125	150	200	1090	50	100	80	50	17.5
ZHKJ 71 <sup>1)</sup>	355	33	30	20	275	1260	190	145	185	240	1320	60	140	120	50	31
ZHKJ 71 <sup>1)</sup>	400	33	30	20	180	1260	190	140	200	240	1320	60	140	120	50	31

<sup>1)</sup> When mounting on a ceiling or on a wall please contact the manufacturer.

Each set includes two complete slide rails including screw for mounting the motor on the rails. Screws for mounting the rails on the foundation are not included. Slide rails are supplied with unmachined lower surfaces and should, prior to tightening down, be supported in a suitable manner.

## Foundation studs for motor sizes 280 - 400

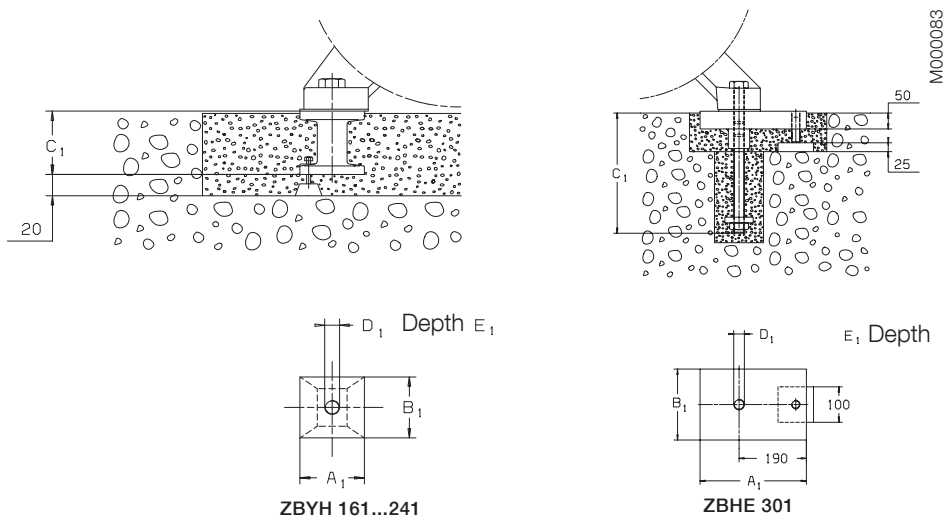

Foundation stud type	Fixing screw	Motor size	Main dimensions					Weight kg
			A1	B1	C1	D1	E1	
ZBYH 201	M20 x 70/70 Y	280	100	100	95	M20	35	3.4
ZBYH 241	M24 x 90/90 Y	315, 355	130	130	135	M24	45	7
ZBHE 301	M30 x 100/100 Y	400	300	200	385	M30	65	30

Each set of foundation studs includes 4 studs, fixing screw for the motor, adjusting screw with foundation plate.

## Protective roof (variant code 005)

Motor size	Poles	Ø	L
280 S_	2	555	1160
	4-12	555	1090
280 SM_	2	555	1160
	4-12	555	1160
280 M_	2	555	1220
	4-12	555	1220
315 S_	2	624	1210
	4-12	624	1240
315 SM_	2	624	1310
	4-12	624	1240
315 M_	2	624	1310
	4-12	624	1340
315 L_	2	624	1380
	4-12	624	1410
355 S_	2	720	1440
	4-12	720	1510
355 M_	2	720	1500
	4-12	720	1570
355 L_	2	720	1580
	4-12	720	1650
355 LK_	4-12	720	1790
	4-12	720	1796
400 ML_	2	810	1796
	4-12	810	1836
400 LK_	2	810	1936
	4-12	810	1976

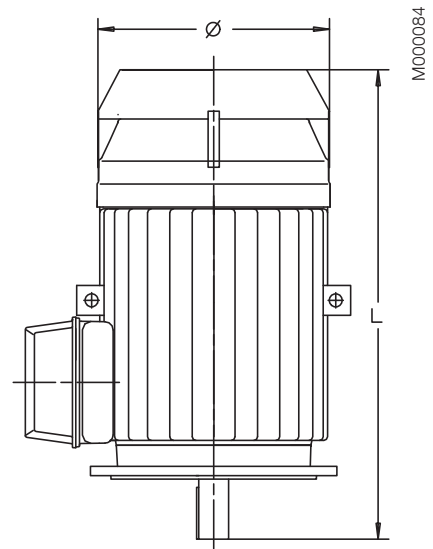

Mounting arrangement IM V1  
with protective roof

## Silencer for motor sizes 280 - 400

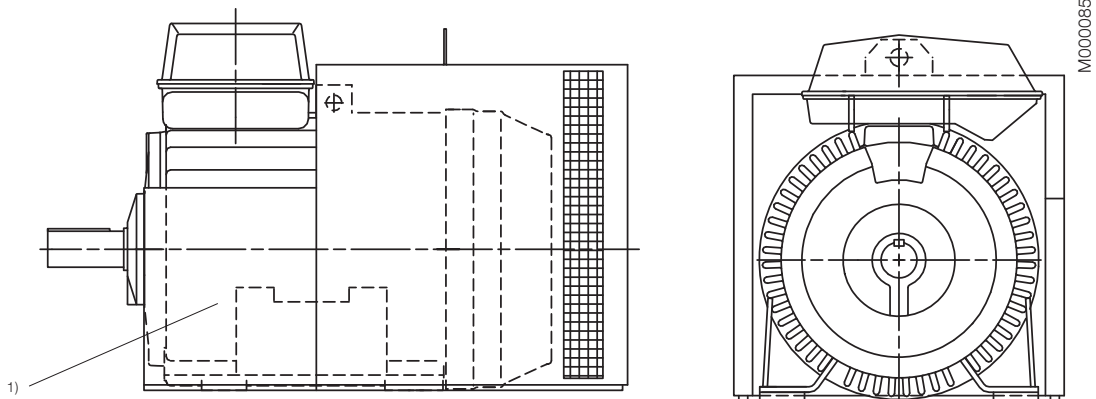

Both foot-mounted and flange-mounted motors can be fitted with a silencer to reduce the noise level by 5-6 dB(A). The silencer is painted blue and is made of 2 mm steel sheet. The sound absorbing material is 40 mm thick polyurethane foam. On the underside there is a rubber strip to seal against the floor. The silencer fits loosely over the motor.

**Dimensions of silencers on request.**

1) If connections to the motor or control gear require it, an opening can be made in the extension of the silencer or it can be removed.

# Industrial performance steel motors in brief, basic design

Motor frame size		280	315	355	400	
<b>Stator</b>	Material	Profile-pressed sheet steel				
	Paint colour shade	Blue, Munsell 8B 4.5/3.25 (NCS 4822-B05G)				
	Paint thickness	Two-pack epoxy paint, thickness $\geq 70 \mu\text{m}$				
<b>Bearing end shields</b>	Material	Cast iron EN-GJL-200 or spheroidal graphit EN-GJS-400				
	Paint colour shade	Blue, Munsell 8B 4.5/3.25 (NCS 4822-B05G)				
	Paint thickness	Two-pack epoxy paint, thickness $\geq 70 \mu\text{m}$				
<b>Bearings</b>	D-end	2-pole	6316/C4	6316/C4	6316M/C3	6317M/C3
		4-12 poles	6316/C3	6319/C3	6322/C3	6322/C3
	N-end	2-pole	6316/C4	6316/C4	6316M/C3	6317M/C3
		4-12 poles	6316/C3	6316/C3	6319/C3	6319/C3
<b>Axially-locked bearings</b>	Inner bearing cover	As standard, locked at D-end				
<b>Bearing seal</b>		V-ring as standard, radial seal on request			2-pole labyrinth seal	
<b>Lubrication</b>		Regreasing nipples, M10x1 Grease for bearing temperatures $-30^{\circ}\text{C}$ to $+120^{\circ}\text{C}$				
<b>SPM-nipples</b>		On request				
<b>Rating plate</b>		Acid proof stainless steel AISI 316, thickness 0.6 mm, with individual serial number				
<b>Terminal box</b>	Frame material	Cast iron EN-GJL-150		Cast iron EN-GJL-250/GG 25/GRS 250		
	Cover material	Cast iron EN-GJL-150		Cast iron EN-GJL-250/GG 25/GRS 250		
	Cover screw material	Steel 8.8, zinc electroplated				
<b>Connections</b>	Cable entries	2-4 pole	2 x M63	2 x M63	2 x $\text{\O}60/80$	2 x $\text{\O}80$
		6-8 pole	2 x M63	2 x M63	2 x $\text{\O}60$	2 x $\text{\O}60/80$
	Terminals	6 terminals for connection with cable lugs (not included)				
<b>Fan</b>	Material	Glass fibre reinforced plastic or aluminum				
<b>Fan cover</b>	Material	Sheet steel				
	Paint colour shade	Blue, Munsell 8B 4.5/3.25 (NCS 4822-B05G)				
	Paint thickness	Two-pack epoxy polyester paint, thickness $\geq 80 \mu\text{m}$				
<b>Stator winding</b>	Material	Copper				
	Insulation	Insulation class F; temperature rise class B unless otherwise stated.				
	Winding protection	PTC-thermistors $150^{\circ}\text{C}$ , 3 in series, as standard				
<b>Rotor winding</b>	Material	Pressure die-cast aluminum				
<b>Balancing method</b>		Half key balancing as standard				
<b>Key ways</b>		Open key way				
<b>Heating elements</b>	On request	50 W	1 x 65 W	2 x 65 W	2 x 65 W	
<b>Drain holes</b>		As standard, open on delivery				
<b>Enclosure</b>		IP 55, higher protection on request				
<b>Cooling method</b>		IC 411				

# Industrial performance cast iron motors

## Totally enclosed squirrel cage

### three phase low voltage motors

#### Sizes 71 to 250, 0.25 to 55 kW



[www.abb.com/motors&generators](http://www.abb.com/motors&generators)

> Motors

>> Low voltage motors

>>> Industrial performance motors

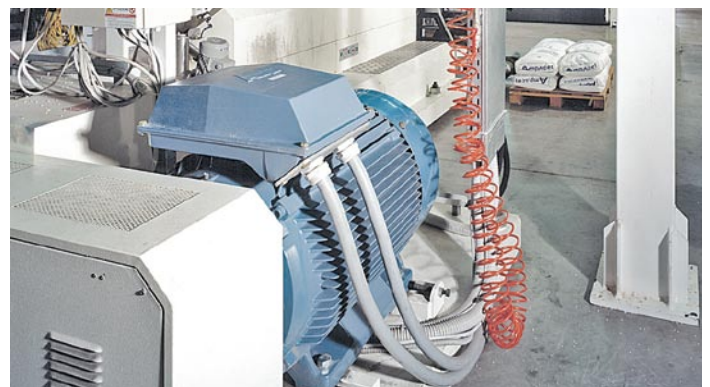

# Mechanical design

## Stator

The motor frames including feet, bearing housing and terminal box are made of cast iron. Integrally cast feet allow a very rigid mounting and minimal vibration.

Motors can be supplied for foot mounting, flange mounting and combinations of these.

## Drain holes

Motors that will be operated in very humid or wet environments, and especially under intermittent duty, should be provided with drain holes. The appropriate IM designation, such as IM 3031, is specified, on the basis of the method of motor mounting.

Motor sizes 71 to 250 are fitted with drain holes and closable plugs. The plugs are open on delivery. When mounting the motors, ensure that the drain holes face downwards.

In the case of vertical mounting, the upper plug must be hammered home completely. In very dusty environments, both plugs should be hammered home.

When mounting arrangement differs from foot mounted IM B3, please mention variant code 066 when ordering.

See variant codes 065 and 066 under the heading “Drain holes”.

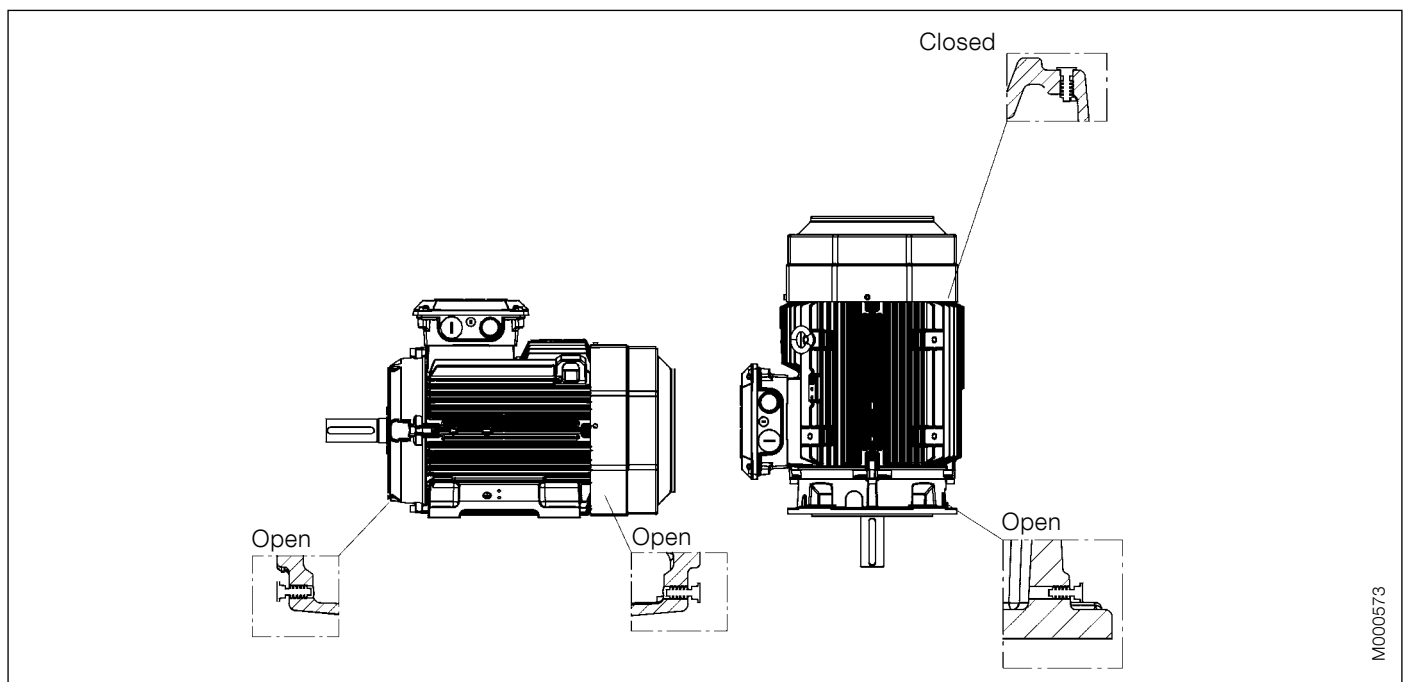

M000573

# Terminal box

Terminal boxes are mounted on the top of the motor as standard. The terminal box can also be mounted on the left or right side, see ordering information.

The terminal boxes of motor sizes 160 to 250 can be rotated 2x180° to allow cable entry from either side of the motor, as option the terminal box can be turned 4x90°.

Degree of protection of standard terminal box is IP 55. In motor sizes 160 to 250 the terminal box is equipped with cable glands or cable boxes as standard, see following pages.

To enable the supply of suitable terminations for the motor, please state cable type, quantity and size when ordering. Non-standard design of terminal boxes; e.g. size, degree of protection, are available as options.

Terminations are suitable for Cu- and Al-cables (Al-cables on request for motor sizes 160 to 250). Cables are connected to the terminals by cable lugs which are not included with the motor.

Please see variant codes for options.

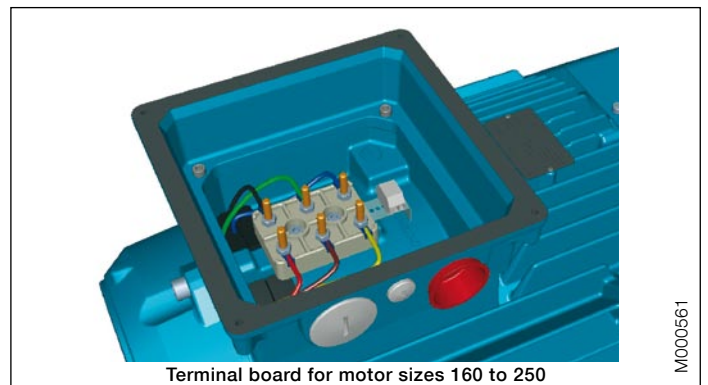
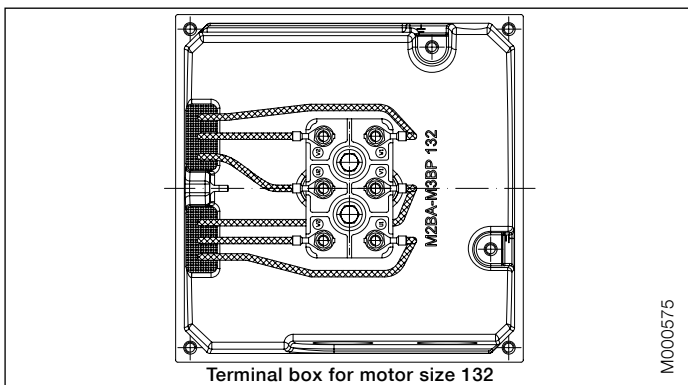
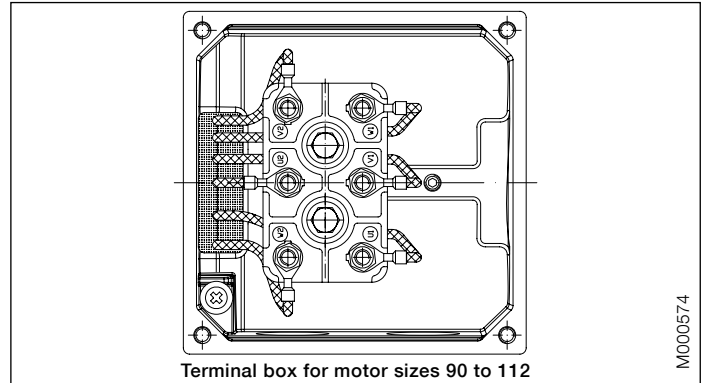
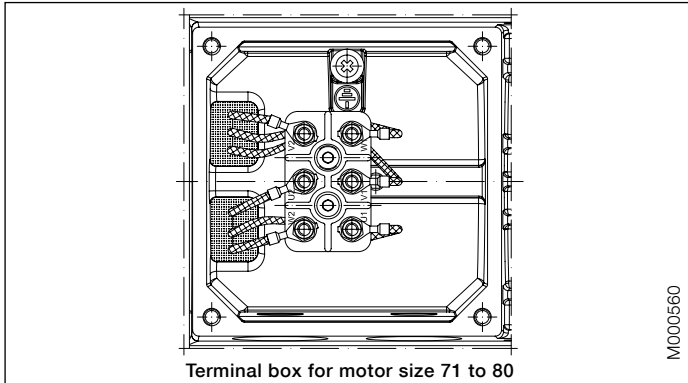

## Dimension drawings Industrial performance cast iron motors

Terminal boxes, standard design with 6 terminals  
Motor sizes 160 - 250

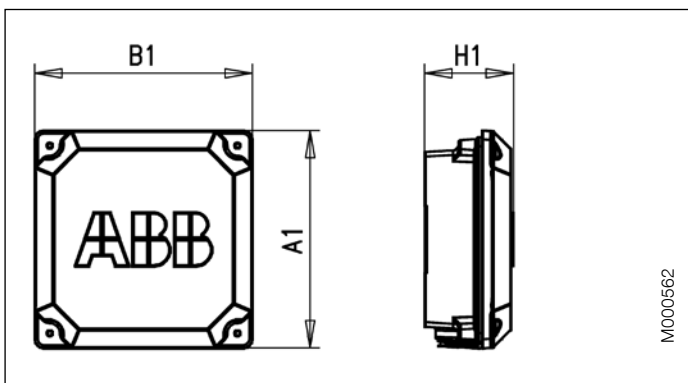

Motor size	A1	B1	H1
160 to 180	239	239	98
200 to 250	257	257	137

# Bearings

The motors are provided with bearings according to the tables below.

Greater axial forces can be tolerated if the motors are provided with angular contact ball bearings.

## Basic version with deep groove ball bearings

Basic design motors		
Motor size	Foot- and flange-mounted motor	
	D-end	N-end
71	6203-2Z/C3	6202-2Z/C3
80	6204-2Z/C3	6203-2Z/C3
90	6205-2Z/C3	6204-2Z/C3
100	6206-2Z/C3	6205-2Z/C3
112	6206-2Z/C3	6205-2Z/C3
132	6208-2Z/C3	6206-2Z/C3
160	6309-2Z/C3	6209-2Z/C3
180	6310-2Z/C3	6209-2Z/C3
200	6312-2Z/C3	6210-2Z/C3
225	6313-2Z/C3	6212-2Z/C3
250	6315-2Z/C3	6213-2Z/C3

Note that in such cases the axial force must only operate in one direction.

Motor versions with roller bearings tolerate greater radial forces.

## Alternative designs:

### Version with roller bearings

It is recommended to use roller bearings in belt drives for motor sizes 160 - 250.

See variant code 037 under the heading "Bearings and lubrication".

Motor size	D-end	N-end
90	NU 205	–
100	NU 306	–
112	NU 306	–
132	NU 208	–
160	NU 309 ECP	–
180	NU 310 ECP	–
200	NU 312 ECP	–
225	NU 313 ECP	–
250	NU 315 ECP	–

### Version with angular contact ball bearings

See variant codes 058 and 059 under the heading "Bearings and lubrication".

Motor size	D-end	N-end
	058	059
90	7205 B	7204 B
100	7306 B	7205 B
112	7306 B	7205 B
132	7208 B	7206 B
160	7309 BEP	7209 BEP
180	7310 BEP	7209 BEP
200	7312 BEP	7210 BEP
225	7313 BEP	7212 BEP
250	7315 BEP	7213 BEP



## Transport locking

Motors provided with roller bearings or angular contact ball bearings are fitted with a transport lock to prevent damage to the bearings, due to vibration, during transport.

## Axially-locked bearings

The table below shows which of the motor's bearings are axially locked in the bearing seat. In motor sizes 71 to 80 the locking is done by an internal retaining ring, in motor sizes 90 to 250 by an inner bearing cover.

See also variant code 042 under the heading "Bearings and lubrication".

Motor size	Foot-mounted motors	Flange-mounted motors	
		Large flange	Small flange
71-132	D-end <sup>1)</sup>	D-end <sup>1)</sup>	D-end <sup>1)</sup>
160-250	D-end	D-end	–

<sup>1)</sup> A spring-washer at the N-end presses the rotor toward the D-end.

## Lubrication

The motors are delivered with bearing grease for use at normal temperatures in dry or humid environments. The motors are lubricated for ambient temperatures 40°C and in some cases even above 40°C, see table 1 next page.

Motor sizes 71 to 250 are provided with shielded bearings. As an option, motor sizes 90 to 250 are provided with grease nipples for regreasing, see variant code 041 under the heading "Bearings and lubrications".

The lubrication interval  $L_1$ , suitable for relubricated bearings, is defined as the number of operating hours after which 99 per cent of the bearings are adequately lubricated.

Lubrication intervals and grease quantities are specified on a plate on the motor as well as in the manual supplied with the motor.

The grease lifetime  $L_{10}$ , suitable for permanent lubricated bearings, is defined as the number of operating hours after which 90 per cent of the bearings are adequately lubricated. 50 per cent of the bearings achieve two times this figure. Maximum lifetime, however, should be regarded as 40,000 hours.

In case of high ambient temperatures the shaft loads must be reduced compared to permissible loadings in the table (see pages 92 to 93), please contact ABB.

**Table 1: Grease lifetime  $L_{10}$  in deep groove ball bearings of type 2Z in horizontally mounted motors in continuous running duty.**

Motor	r/min	Ambient temperature and rated output											
		25 °C		40 °C		50 °C		60 °C		70 °C		80 °C	
		Basic	High	Basic	High	Basic	High	Basic	High	Basic	High	Basic	High
71	3000	40000	40000	40000	40000	40000	40000	27000	27000	15000	15000	8000	8000
	1500	40000	40000	40000	40000	40000	40000	33000	33000	18000	18000	9000	9000
	1000	40000	40000	40000	40000	40000	40000	33000	33000	18000	18000	9000	9000
	750	40000	40000	40000	40000	40000	40000	33000	33000	18000	18000	9000	9000
80	3000	40000	40000	40000	40000	39000	39000	23000	23000	13000	13000	7000	7000
	1500	40000	40000	40000	40000	40000	40000	33000	33000	18000	18000	9000	9000
	1000	40000	40000	40000	40000	40000	40000	33000	33000	18000	18000	9000	9000
	750	40000	40000	40000	40000	40000	40000	33000	33000	18000	18000	9000	9000
90	3000	40000	40000	40000	40000	33000	33000	20000	20000	11000	11000	6000	6000
	1500	40000	40000	40000	40000	40000	40000	33000	33000	18000	18000	9000	9000
	1000	40000	40000	40000	40000	40000	40000	33000	33000	18000	18000	9000	9000
	750	40000	40000	40000	40000	40000	40000	33000	33000	18000	18000	9000	9000
100	3000	40000	40000	39000	39000	25000	25000	15000	15000	8000	8000	4000	4000
	1500	40000	40000	40000	40000	40000	40000	30000	30000	17000	17000	9000	9000
	1000	40000	40000	40000	40000	40000	40000	33000	33000	18000	18000	9000	9000
	750	40000	40000	40000	40000	40000	40000	33000	33000	18000	18000	9000	9000
112	3000	40000	40000	39000	39000	25000	25000	15000	15000	8000	8000	4000	4000
	1500	40000	40000	40000	40000	40000	40000	30000	30000	17000	17000	9000	9000
	1000	40000	40000	40000	40000	40000	40000	33000	33000	18000	18000	9000	9000
	750	40000	40000	40000	40000	40000	40000	33000	33000	18000	18000	9000	9000
132	3000	40000	40000	33000	33000	21000	21000	13000	13000	7000	7000	4000	4000
	1500	40000	40000	40000	40000	40000	40000	26000	26000	14000	14000	7000	7000
	1000	40000	40000	40000	40000	40000	40000	33000	33000	18000	18000	9000	9000
	750	40000	40000	40000	40000	40000	40000	33000	33000	18000	18000	9000	9000
160	3000	40000	40000	40000	36000	40000	19000	26000	9000	14000	5000	8000	2000
	1500	40000	40000	40000	40000	40000	40000	40000	38000	40000	20000	37000	10000
	1000	40000	40000	40000	40000	40000	40000	40000	40000	40000	24000	40000	12000
	750	40000		40000		40000		40000		40000		40000	
180	3000	38000	38000	38000	38000	38000	38000	38000	23000	23000	12000	13000	7000
	1500	40000	40000	40000	40000	40000	24000	40000	12000	26000	6000	13000	3000
	1000	40000	40000	40000	40000	40000	40000	40000	40000	40000	24000	29000	12000
	750	40000		40000		40000		40000		37000		21000	
200	3000	27000	27000	27000	27000	27000	18000	24000	10000	14000	5000	8000	3000
	1500	40000	40000	40000	40000	40000	40000	40000	32000	40000	18000	30000	10000
	1000	40000	40000	40000	40000	40000	40000	40000	40000	40000	30000	38000	17000
	750	40000		40000		40000		40000		40000		40000	
225	3000	23000	23000	23000	18000	23000	10000	20000	6000	12000	3000	7000	1000
	1500	40000	40000	40000	40000	40000	23000	40000	12000	40000	6000	25000	3000
	1000	40000	40000	40000	40000	40000	40000	40000	40000	40000	40000	40000	27000
	750	40000		40000		40000		40000		40000		40000	
250	3000	16000	16000	16000	13000	16000	7000	12000	4000	7000	2000	4000	1000
	1500	40000	40000	40000	39000	40000	21000	40000	11000	33000	6000	19000	3000
	1000	40000	40000	40000	40000	40000	40000	40000	40000	40000	25000	36000	13000
	750	40000		40000		40000		40000		40000		40000	

In vertically mounted motors, the grease lifetime is half the figures above.

For applications corresponding to the empty cells in the table, please contact ABB. These applications can imply reduced lifetime for bearings and winding.

Motors with roller bearings (optional) have considerably shorter grease life. For continuous operation regreasing nipples should be considered.

# Pulley diameter

When the desired bearing life has been determined the minimum permissible pulley diameter can be calculated with  $F_R$ , according to the formula:

$$D = \frac{1.9 \cdot 10^7 \cdot K \cdot P}{n \cdot F_R}$$

where:

$D$  = diameter of pulley, mm

$P$  = power requirement, kW

$n$  = motor speed, r/min.

$K$  = belt tension factor, dependent on belt type and type of duty. A common value for V-belts is  $K = 2.5$

$F_R$  = permissible radial force according to the tables

# Bearing life

The nominal life is defined as the number of hours that are attained or exceeded by 90 percent of identical bearings, in a large test series, under certain specified conditions. 50 percent of the bearings attain a life of as much as 5 times this figure.

The life of bearings is dependent on various factors such as bearing load, motor speed, operating temperature and the purity of the grease. The permissible radial and axial loading for different motor sizes is shown in the table on the following pages.

The table is valid for 50 Hz. For 60 Hz and/or some other bearing life than specified in the table the values are

changed according to the table on the right.

The table values assume the occurrence of only radial or axial forces. In the case of simultaneous radial and axial forces information can be supplied on request. It is assumed that the radial force is applied at the end of the motor shaft.

## Permissible force at changed bearing life or supply frequency

Bearing life in hours at		Permissible force, as percentage of value in tables
50 Hz	60 Hz	
25,000	21,000	100 % of value for 25,000 hours
40,000	33,000	100 % of value for 40,000 hours
63,000	52,000	86 % of value for 40,000 hours
80,000	67,000	80 % of value for 40,000 hours

# Permissible loadings on shaft

The tables give the permissible radial force in Newtons, assuming zero axial force, ambient temperature of 25°C.

Permissible loads of simultaneous radial and axial forces will be supplied on request.

The bearing life,  $L_{10}$ , is calculated according to SKF's theory on bearing life  $L_{10_{aah}}$ , which also takes the purity of the grease into consideration. An adequate lubrication is a necessary prerequisite for the table at right.

If the radial force is applied between points  $X_0$  and  $X_{max}$ , the permissible force  $F_R$  can be calculated from the following formula:

$$F_R = F_{X_0} - \frac{X}{E} (F_{X_0} - F_{X_{max}})$$

$E$  = length of shaft extension in basic version.

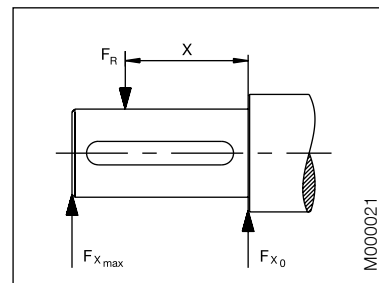

## Permissible radial forces

### Motor sizes 71 to 250

Motor size	No. of poles	Length of shaft extension E (mm)	Ball bearings			
			Basic design with deep groove ball bearings			
			25,000 hrs		40,000 hrs	
			$FX_0$ (N)	$FX_{max}$ (N)	$FX_0$ (N)	$FX_{max}$ (N)
71	2	30	680	570	680	570
	4	30	680	570	680	570
	6	30	680	570	680	570
	8	30	680	570	680	570
80	2	40	930	750	930	750
	4	40	930	750	930	750
	6	40	930	750	930	750
	8	40	930	750	930	750
90	2	50	1010	810	1010	810
	4	50	1010	810	1010	810
	6	50	1010	810	1010	810
	8	50	1010	810	1010	810
100	2	60	1755	1385	1755	1385
	4	60	1755	1385	1755	1385
	6	60	1755	1385	1755	1385
	8	60	1755	1385	1755	1385
112	2	60	1755	1385	1755	1385
	4	60	1755	1385	1755	1385
	6	60	1755	1385	1755	1385
	8	60	1755	1385	1755	1385
132	2	80	2120	1610	2120	1610
	4	80	2120	1610	2120	1610
	6	80	2120	1610	2120	1610
	8	80	2120	1610	2120	1610

Motor size	No. of poles	Length of shaft extension E (mm)	Ball bearings				Roller bearings			
			Basic design with deep groove ball bearings				Alternative design with roller bearings			
			20,000 hrs		40,000 hrs		20,000 hrs		40,000 hrs	
			$FX_0$ (N)	$FX_{max}$ (N)	$FX_0$ (N)	$FX_{max}$ (N)	$FX_0$ (N)	$FX_{max}$ (N)	$FX_0$ (N)	$FX_{max}$ (N)
160	2	110	4760	3860	4100	3320	6580	4300	5620	4300
	4	110	5180	4200	4380	3545	7340	4300	6180	4300
	6	110	5160	4180	4360	3540	7780	4300	6500	4300
	8	110	6280	4300	5320	4300	8860	4300	7440	4300
180	2	110	6060	4960	5280 <sup>1)</sup>	4305 <sup>1)</sup>	7600	5500	6560	5500
	4	110	4800	3940	4020	3300	7280	5500	6140	5500
	6	110	6280	5140	5280	4380	8680	5500	7280	5500
	8	110	6960	5500	5880	4800	9440	5500	7920	5500
200	2	110	7800	6500	6760 <sup>2)</sup>	5640 <sup>2)</sup>	10360	8640	8880	7400
	4	110	8400	7020	7180	5980	11560	9550	9800	8180
	6	110	8960	7480	7600	6340	12480	9550	10520	8780
	8	110	10480	8740	8940	7400	14100	9550	11920	9550
225	2	110	8520	7180	7360 <sup>3)</sup>	6200 <sup>3)</sup>	12320	10380	10560	8900
	4	140	8380	6780	7200	5820	13380	10250	11320	9160
	6	140	10960	8860	9360	7560	15860	10250	13420	10250
	8	140	12100	9780	10340	8360	17220	10250	14580	10250
250	2	140	10480 <sup>4)</sup>	8500 <sup>4)</sup>	9080 <sup>4)</sup>	7360 <sup>4)</sup>	16220	10900	13960	10900
	4	140	10840	8780	9380	7600	18020	13800	15320	13800
	6	140	12600	10220	10700	8680	20240	13800	17140	13800
	8	140	14660	11880	12540	10160	22680	13800	19220	13800

<sup>1)</sup> The maximum lifetime of the grease is 38 000 h, see page 90.

<sup>2)</sup> The maximum lifetime of the grease is 27 000 h, see page 90.

<sup>3)</sup> The maximum lifetime of the grease is 23 000 h, see page 90.

<sup>4)</sup> The maximum lifetime of the grease is 16 000 h, see page 90.

### Permissible axial forces

The following tables give the permissible axial forces in Newton, assuming zero radial force, ambient temperature 25°C. The values are based on normal conditions at 50 Hz with standard bearings and calculated bearing lives of 20,000 and 40,000 hours.

For two-speed motors, the values are to be based on the higher speed. The permissible loads of simultaneous radial and axial forces will be supplied on request.

Given axial forces  $F_{AD}$ , assumes D-bearing locked by means of locking ring.

At 60 Hz the values are to be reduced by 10 percent.

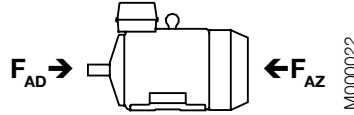

### Mounting arrangement IM B3

Motor size	20,000 hours								40,000 hours							
	2-pole		4-pole		6-pole		8-pole		2-pole		4-pole		6-pole		8-pole	
	$F_{AD}$ N	$F_{AZ}$ N	$F_{AD}$ N	$F_{AZ}$ N	$F_{AD}$ N	$F_{AZ}$ N	$F_{AD}$ N	$F_{AZ}$ N	$F_{AD}$ N	$F_{AZ}$ N	$F_{AD}$ N	$F_{AZ}$ N	$F_{AD}$ N	$F_{AZ}$ N	$F_{AD}$ N	$F_{AZ}$ N
71	625	325	780	480	890	590	985	685	515	215	630	330	710	410	780	480
80	810	470	1015	675	1170	830	1300	960	650	315	810	470	925	595	1015	675
90	885	485	1170	650	1270	870	1410	1010	720	320	945	425	1005	605	1110	710
100	1270	770	1715	1215	2040	1540	2310	1810	930	430	1265	765	1515	1015	1715	1215
112	1265	765	1710	1210	2035	1535	2305	1805	925	425	1260	760	1510	1010	1710	1210
132	1770	1170	2235	1635	2600	2000	2885	2285	1400	800	1750	1150	2030	1435	2245	1645
160	4160	4160	4740	4740	4840	4840	5980	5980	3425	3425	3920	3920	4000	4000	4920	4920
180	5480	5480	4360	4360	5980	5980	6000	6620	4600 <sup>1)</sup>	4600 <sup>1)</sup>	3540	3540	4940	4940	5460	5460
200	5000	6880	5000	7660	5000	8300	5000	9880	5000 <sup>2)</sup>	5700 <sup>2)</sup>	5000	6340	5000	6880	5000	8160
225	5000	7380	5000	7600	5000	10140	5000	11420	5000 <sup>3)</sup>	6120 <sup>3)</sup>	5000	6220	5000	8420	5000	9460
250	6000 <sup>4)</sup>	9020 <sup>4)</sup>	6000	9800	6000	11520	6000	13700	6000 <sup>4)</sup>	7500 <sup>4)</sup>	6000	8040	6000	9520	6000	11380

<sup>1)</sup> The maximum lifetime of the grease is 38 000 h, see page 90.  
<sup>2)</sup> The maximum lifetime of the grease is 27 000 h, see page 90.  
<sup>3)</sup> The maximum lifetime of the grease is 23 000 h, see page 90.  
<sup>4)</sup> The maximum lifetime of the grease is 16 000 h, see page 90.

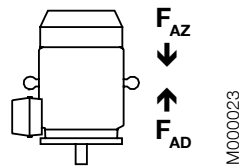

### Mounting arrangement IM V1

Motor size	20,000 hours								40,000 hours							
	2-pole		4-pole		6-pole		8-pole		2-pole		4-pole		6-pole		8-pole	
	$F_{AD}$ N	$F_{AZ}$ N	$F_{AD}$ N	$F_{AZ}$ N	$F_{AD}$ N	$F_{AZ}$ N	$F_{AD}$ N	$F_{AZ}$ N	$F_{AD}$ N	$F_{AZ}$ N	$F_{AD}$ N	$F_{AZ}$ N	$F_{AD}$ N	$F_{AZ}$ N	$F_{AD}$ N	$F_{AZ}$ N
71	640	315	800	470	925	570	1020	665	530	200	650	320	745	390	815	455
80	845	450	1075	640	1225	795	1350	925	690	290	865	430	980	550	1070	645
90	945	450	1245	600	1360	815	1485	960	775	280	1020	375	1095	550	1185	660
100	1350	700	1820	1125	2150	1455	2420	1720	1010	355	1375	675	1620	925	1825	1125
112	1360	690	1830	1115	2160	1445	2430	1710	1020	350	1390	665	1640	915	1840	1110
132	1910	1075	2460	1505	2815	1850	3100	2145	150	705	2010	980	2210	1315	2460	1505
160	4560	3810	5260	4310	5400	4420	6560	5580	3860	3110	4440	3490	4540	3560	5460	4480
180	5920	5115	5080	3860	6000	5445	6000	6120	5060 <sup>1)</sup>	4255 <sup>1)</sup>	4240	3020	5600	4385	6000	4900
200	5000	6350	5000	6950	5000	7505	5000	9215	5000 <sup>2)</sup>	5230 <sup>2)</sup>	5000	5650	5000	6025	5000	7435
225	5000	6770	5000	6795	5000	9270	5000	10595	5000 <sup>3)</sup>	5490 <sup>3)</sup>	5000	5475	5000	7490	5000	8535
250	6000 <sup>4)</sup>	8335 <sup>4)</sup>	6000	8820	6000	10275	6000	12645	6000 <sup>4)</sup>	6755 <sup>4)</sup>	6000	7120	6000	8235	6000	10205

<sup>1)</sup> The maximum lifetime of the grease is 38 000 h, see page 90.  
<sup>2)</sup> The maximum lifetime of the grease is 27 000 h, see page 90.  
<sup>3)</sup> The maximum lifetime of the grease is 23 000 h, see page 90.  
<sup>4)</sup> The maximum lifetime of the grease is 16 000 h, see page 90.

# Rating plates

The rating plate is in table form giving values for speed, current and power factor for three voltages.

The following information must be shown on the motor rating plate according to IEC 60034-30; 2008 and European MEPS (Commission Regulation, EC, No 640/2009):

- Lowest nominal efficiency at 100, 75 and 50 percent rated load
- Efficiency level (IE2 or IE3)
- Year of manufacture

## Motor sizes 71 to 90

<b>ABB</b> 3~Motor M3BA 090 LD 4						IE2 <b>CE</b>	
3GBA092325-ASB						No. E102509P8050	
6205-2Z/C3			6204-2Z/C3			28 kg	
V	Hz	r/min	kW	A	Cos φ		
230 D / 400 Y	50	1435	1,5	5,5 / 3,2	0,78		
415 Y	50	1440	1,5	3,2	0,76		
IE2-84,2(100%)-83,6(75%)-80,9(50%)						2009 IEC 60034-1	

M000563

## Motor sizes 100 to 132

<b>ABB</b> 3~Motor M3BA 100 L 6						IE2 <b>CE</b>	
3GBA103322-ASB						Cl. F IP 55	
Sr. No. E102510P9045						2009	
V	Hz	r/min	kW	A	Cos φ		
230 D	50	950	1,5	6,4	0,69		
400 Y	50	950	1,5	3,7	0,69		
415 Y	50	955	1,5	3,7	0,68		
IE2-82,1(100%)-82,2(75%)-80,2(50%)							
6206-2Z/C3						6205-2Z/C3	
						36 kg	
						IEC 60034-1	

M000564

## Motor sizes 160 to 180

<b>ABB</b> 3~ Motor M3BA 180 MLB 4						IE2 <b>CE</b>	
Cl. F IP 55						IEC 60034-1	
V	Hz	kW	r/min	A	cos φ duty		
690 Y	50	22	1475	24,0	0,83 S1		
400 Δ	50	22	1475	41,5	0,83 S1		
415 Δ	50	22	1477	40,4	0,82 S1		
Prod. code 3GBA182032-ADG						No 3GV0922345678001	
50 Hz: IE2 - 92,1(100%) - 93,1(75%) - 93,0(50%)						2009	
6313-2Z/C3						6212-2Z/C3	
						221 kg	
spare-parts:www.abb.com/partsonline							

M000576

## Motor sizes 200 to 250

<b>ABB</b> 3~Motor M3BA 225 SMA 4						IE2 <b>CE</b>	
2009						No 3GV0923456789001	
Ins. cl. F						IP 55	
V	Hz	kW	r/min	A	cos φ duty		
690 Y	50	37	1479	39,2	0,84 S1		
400 Δ	50	37	1479	68	0,84 S1		
415 Δ	50	37	1481	68	0,81 S1		
50 Hz: IE2 - 93,4(100%) - 93,9(75%) - 93,4(50%)							
Prod. code 3GBA222031-ADG							
6313-2Z/C3						6212-2Z/C3	
						323 kg	
spare-parts:www.abb.com/partsonline						IEC 60034-1	

M000577

# Ordering information

When placing an order, please state the following minimum data in the order, as in the example.

The product code of the motor is composed in accordance with the following example.

<b>Motor type</b>	<b>M3BA 160 MLC</b>
<b>Pole number</b>	<b>2</b>
<b>Mounting arrangement (IM-code)</b>	<b>IM B3 (IM 1001)</b>
<b>Rated output</b>	<b>18.5 kW</b>
<b>Product code</b>	<b>3GBA 161033-ADG</b>
<b>Variant codes if needed</b>	

## Motor size

A	B	C	D, E, F	G
<b>M3BA</b>	<b>160 MLC</b>	<b>3GBA 161 033</b>	<b>- ADG, 003 etc.</b>	
		1   2   3   4   5   6   7   8   9   10   11   12   13   14...		
A Motor type		D Code for mounting arrangement	E Voltage and frequency code	F Generation code
B Motor size				G Variant codes
C Product code				

## Explanation of the product code

### Positions 1 to 4

**3GBP** = Totally enclosed fan cooled squirrel cage motor with cast iron frame

### Positions 5 and 6

IEC-frame

- 07** = 71
- 08** = 80
- 09** = 90
- 10** = 100
- 11** = 112
- 13** = 132
- 16** = 160
- 18** = 180
- 20** = 200
- 22** = 225
- 25** = 250

### Position 7

Speed (Pole pairs)

- 1** = 2 poles
- 2** = 4 poles
- 3** = 6 poles
- 4** = 8 poles
- 5** = 10 poles
- 6** = 12 poles
- 7** = >12 poles
- 8** = Two-speed motors for fan drive
- 9** = Multi-speed motors, two-speed motors for constant torque

### Position 8 to 10

Serial number

### Position 11

- (dash)

### Position 12

Mounting arrangement

- A** = Foot-mounted, top-mounted terminal box
- R** = Foot-mounted, terminal box RHS seen from D-end
- L** = Foot-mounted, terminal box LHS seen from D-end
- B** = Flange-mounted, large flange
- C** = Flange-mounted, small flange (sizes 71 to 112)
- H** = Foot- and flange-mounted, terminal box top-mounted
- J** = Foot- and flange-mounted, small flange with tapped holes
- S** = Foot- and flange-mounted, terminal box RHS seen from D-end
- T** = Foot- and flange-mounted, terminal box LHS seen from D-end
- V** = Flange-mounted, special flange
- F** = Foot- and flange-mounted. Special flange

### Position 13

Voltage and frequency code

Single-speed motors

- B** 380 VΔ 50 Hz
- D** 400 VΔ, 415 VΔ, 690 VY 50 Hz
- E** 500 VΔ 50 Hz
- F** 500 VY 50 Hz
- S** 230 VΔ, 400 VY, 415 VY 50 Hz
- T** 660 VΔ 50 Hz
- U** 690 VΔ 50 Hz
- X** Other rated voltage, connection or frequency, 690 V maximum

Two-speed motors

- A** 220 V 50 Hz
- B** 380 V 50 Hz
- D** 400 V 50 Hz
- E** 500 V 50 Hz
- S** 230 V 50 Hz
- X** Other rated voltage, connection or frequency, 690 V maximum

**Remark:** For voltage code X the variant code '209 Non-standard voltage or frequency (special winding)' must be ordered.

### Position 14

Generation code

A, B, C...G

**The product code must be, if needed, followed by variant codes.**

# Industrial performance cast iron motors

## Technical data for totally enclosed squirrel cage three phase motors

IE2

IP 55 - IC 411 - Insulation class F, temperature rise class B  
IE2 efficiency class according to IEC 60034-30; 2008

Output kW	Motor type	Product code	Speed r/min	Efficiency IEC 60034-2-1; 2007			Power factor cos φ	Current		Torque			Moment of inertia J = 1/4 GD <sup>2</sup> kgm <sup>2</sup>	Weight kg	Sound pressure level L <sub>PA</sub> dB
				Full load 100%	3/4 load 75%	1/2 load 50%		I <sub>N</sub> A	I <sub>s</sub> / I <sub>N</sub>	T <sub>N</sub> Nm	T <sub>l</sub> / T <sub>N</sub>	T <sub>b</sub> / T <sub>N</sub>			
<b>3000 r/min = 2-poles 400 V 50 Hz</b>			<b>CENELEC-design</b>												
0.37	M3BA 71 A	3GBA 071 321-••B	2505	69.2	73.5	73.7	0.80	0.96	3.9	1.41	2.2	2.3	0.00039	11	58
0.55	M3BA 71 B	3GBA 071 322-••B	2680	73.2	77.3	79.3	0.85	1.27	4.3	1.95	2.4	2.5	0.00051	11	56
0.75	M3BA 80 B	3GBA 081 322-••B	2890	82.5	81.6	78.2	0.72	1.82	7.7	2.4	4.2	4.3	0.001	16	57
1.1	M3BA 80 C	3GBA 081 323-••B	2880	82.9	82.9	80.2	0.78	2.4	7.6	3.6	2.8	3.6	0.0012	18	60
1.5	M3BA 90 L	3GBA 091 322-••B	2900	82.2	84.1	82.7	0.86	3	7.5	4.9	2.5	2.6	0.00254	24	69
2.2	M3BA 90 LB	3GBA 091 323-••B	2885	84.7	86.7	85.7	0.87	4.3	6.8	7.2	1.9	2.5	0.0028	25	64
3	M3BA 100 LB	3GBA 101 322-••B	2925	85.2	84.9	82.8	0.86	5.9	9.1	9.7	3.1	3.5	0.00528	36	68
4	M3BA 112 MB	3GBA 111 322-••B	2895	86.1	87.0	86.6	0.86	7.7	8.1	13.1	2.9	3.2	0.00575	37	70
5.5	M3BA 132 SB	3GBA 131 322-••B	2865	88.0	88.6	88.0	0.86	10.4	7.0	18.3	2.0	2.7	0.01275	68	70
7.5	M3BA 132 SBB	3GBA 131 324-••B	2890	88.6	88.8	87.5	0.84	14.5	7.3	24.7	2.0	3.6	0.01359	70	70
11	M3BA 160 MLA	3GBA 161 031-••G	2938	90.7	91.5	91.1	0.91	19.2	7.5	35.7	2.4	3.1	0.044	127	69
15	M3BA 160 MLB	3GBA 161 036-••G	2934	91.5	92.5	92.2	0.91	26	7.5	48.8	2.5	3.3	0.053	141	69
18.5	M3BA 160 MLC	3GBA 161 037-••G	2932	92.0	93.1	93.1	0.92	31.5	7.5	60.2	2.9	3.4	0.063	170	69
22	M3BA 180 MLA	3GBA 181 031-••G	2952	92.2	92.7	92.2	0.87	39.5	7.7	71.1	2.8	3.3	0.076	190	69
30	M3BA 200 MLA	3GBA 201 035-••G	2956	93.1	93.5	92.9	0.90	51.6	7.7	96.9	2.7	3.1	0.178	283	72
37	M3BA 200 MLB	3GBA 201 036-••G	2959	93.4	93.7	93.0	0.90	63.5	8.2	119	3.0	3.3	0.196	298	72
45	M3BA 225 SMA	3GBA 221 031-••G	2961	93.6	93.9	93.1	0.88	78.8	6.7	145	2.5	2.5	0.244	347	74
55	M3BA 250 SMA	3GBA 251 031-••G	2967	94.1	94.4	93.8	0.88	95.8	6.8	177	2.2	2.7	0.507	405	75
<b>3000 r/min = 2-poles 400 V 50 Hz</b>			<b>High-output design</b>												
22	<sup>1)</sup> M3BA 160 MLD	3GBA 161 034-••G	2933	91.7	92.9	92.9	0.91	38	8.1	71.6	3.2	3.6	0.063	170	69
30	<sup>1)2)</sup> M3BA 160 MLE	3GBA 161 035-••G	2925	91.7	93.1	93.3	0.91	51.8	7.8	97.9	3.1	3.4	0.072	184	69
30	M3BA 180 MLB	3GBA 181 032-••G	2950	92.8	93.5	93.3	0.88	53	7.9	97.1	2.8	3.3	0.092	208	69
45	<sup>1)</sup> M3BA 200 MLC	3GBA 201 033-••G	2957	93.3	93.8	93.2	0.88	79.1	8.1	145	3.1	3.3	0.196	298	72
55	M3BA 225 SMB	3GBA 221 032-••G	2961	93.9	94.3	93.6	0.88	96	6.5	177	2.4	2.5	0.274	369	74
55	<sup>1)</sup> M3BA 200 MLD	3GBA 201 034-••G	2953	93.8	94.5	94.3	0.89	95	7.8	177	2.9	3.3	0.217	314	72
75	<sup>1)</sup> M3BA 250 SMB	3GBA 251 032-••G	2970	94.6	94.9	94.4	0.89	128	7.6	241	2.8	3.1	0.583	451	75
75	<sup>1)</sup> M3BA 225 SMC	3GBA 221 033-••G	2969	94.5	94.7	94.0	0.84	136	7.4	241	3.2	3.1	0.309	396	74
80	<sup>1)</sup> M3BA 225 SMD	3GBA 221 034-••G	2964	94.5	94.9	94.3	0.87	140	7.3	257	3.0	2.8	0.329	410	74
90	<sup>1)</sup> M3BA 250 SMC	3GBA 251 033-••G	2971	95.0	95.3	95.0	0.89	153	7.6	289	2.5	3.1	0.644	487	75

<sup>1)</sup> Temperature rise class F

<sup>2)</sup> Efficiency level IE1.

The bullets in the product code indicate choice of mounting arrangement, voltage and frequency, generation code (see ordering information page).

I<sub>s</sub> / I<sub>N</sub> = Starting current

T<sub>l</sub> / T<sub>N</sub> = Locked rotor torque

T<sub>b</sub> / T<sub>N</sub> = Breakdown torque

Efficiency values are given according to IEC 60034-2-1; 2007.

Please note that the values are not comparable without knowing the testing method.

ABB has calculated the efficiency values according to indirect method, stray load losses (additional losses) determined from measuring.



# Industrial performance cast iron motors

## Technical data for totally enclosed squirrel cage three phase motors

IE2

IP 55 - IC 411 - Insulation class F, temperature rise class B  
IE2 efficiency class according to IEC 60034-30; 2008

Output kW	Motor type	Product code	Speed r/min	Efficiency IEC 60034-2-1; 2007			Power factor cos φ	Current		Torque			Moment of inertia J = 1/4 GD <sup>2</sup> kgm <sup>2</sup>	Weight kg	Sound pressure level L <sub>PA</sub> dB
				Full load 100%	3/4 load 75%	1/2 load 50%		I <sub>N</sub> A	I <sub>s</sub> / I <sub>N</sub>	T <sub>N</sub> Nm	T <sub>l</sub> / T <sub>N</sub>	T <sub>b</sub> / T <sub>N</sub>			
<b>1500 r/min = 4-poles</b>		<b>400 V 50 Hz</b>		<b>GENELEC-design</b>											
0.25	M3BA 71 A	3GBA 072 321-••B	1365	68.3	70.8	69.7	0.81	0.65	3.5	1.74	1.9	2.0	0.00074	10	45
0.37	M3BA 71 B	3GBA 072 322-••B	1380	72.4	74.5	74.6	0.83	0.88	4.0	2.5	1.6	2.1	0.00088	11	45
0.55	M3BA 80 A	3GBA 082 321-••B	1415	74.5	73.8	70.0	0.73	1.45	5.0	3.7	2.0	2.8	0.00144	15	45
0.75	M3BA 80 D	3GBA 082 324-••B	1430	81.0	80.7	77.3	0.73	1.83	5.3	5	2.7	3.2	0.00205	17	50
1.1	M3BA 90 LB	3GBA 092 324-••B	1430	83.7	84.0	82.2	0.78	2.4	6.2	7.3	2.7	3.1	0.00491	26	56
1.5	M3BA 90 LD	3GBA 092 325-••B	1435	85.0	84.8	82.9	0.78	3.2	6.8	9.9	2.9	3.4	0.00538	28	56
2.2	M3BA 100 LC	3GBA 102 323-••B	1450	85.9	85.1	83.4	0.78	4.7	6.4	14.4	2.9	3.6	0.00948	36	56
3	M3BA 100 LD	3GBA 102 324-••B	1450	86.8	87.0	85.4	0.79	6.3	7.7	19.7	2.9	3.4	0.011	38	58
4	M3BA 112 MB	3GBA 112 322-••B	1440	86.8	87.7	87.3	0.81	8.2	7.0	26.5	2.5	2.9	0.0125	44	59
5.5	M3BA 132 M	3GBA 132 322-••B	1460	89.0	89.8	88.9	0.80	11.1	5.9	35.9	1.7	2.4	0.03282	70	67
7.5	M3BA 132 MB	3GBA 132 323-••B	1450	89.3	90.1	90.0	0.81	14.9	5.6	49.3	1.6	2.4	0.03659	73	64
11	M3BA 160 MLA	3GBA 162 031-••G	1466	90.4	91.6	91.3	0.84	20.9	6.8	71.6	2.2	2.8	0.081	135	62
15	M3BA 160 MLB	3GBA 162 032-••G	1470	91.4	92.4	92.2	0.83	28.5	7.1	97.4	2.6	3.0	0.099	165	62
18.5	M3BA 180 MLA	3GBA 182 031-••G	1477	91.9	92.9	92.7	0.84	34.5	7.2	119	2.6	2.9	0.166	205	62
22	M3BA 180 MLB	3GBA 182 032-••G	1475	92.4	93.3	93.2	0.84	40.9	7.3	142	2.6	3.0	0.195	222	62
30	M3BA 200 MLA	3GBA 202 031-••G	1480	93.2	94.0	93.7	0.84	55.3	7.4	193	2.8	3.0	0.309	291	63
37	M3BA 225 SMA	3GBA 222 031-••G	1479	93.4	93.9	93.4	0.84	68	7.1	238	2.6	2.9	0.356	324	66
45	M3BA 225 SMB	3GBA 222 032-••G	1480	93.9	94.3	93.9	0.85	81.3	7.5	290	2.8	3.2	0.44	356	66
55	M3BA 250 SMA	3GBA 252 031-••G	1480	94.4	95.0	94.7	0.85	98.9	7.0	354	2.6	2.9	0.765	414	67
<b>1500 r/min = 4-poles</b>		<b>400 V 50 Hz</b>		<b>High-output design</b>											
18.5	M3BA 160 MLC	3GBA 162 033-••G	1469	91.4	92.5	92.3	0.84	34.7	7.6	120	3.0	3.2	0.11	173	62
22 <sup>2)</sup>	M3BA 160 MLD	3GBA 162 034-••G	1463	91.6	93.0	93.2	0.85	40.7	6.9	143	2.5	2.9	0.125	187	62
30 <sup>1)</sup>	M3BA 180 MLC	3GBA 182 033-••G	1474	92.3	93.5	93.5	0.83	56.5	7.3	194	2.7	2.9	0.217	235	62
37	M3BA 200 MLB	3GBA 202 032-••G	1479	93.4	94.4	94.4	0.85	67.2	7.1	238	2.6	2.9	0.343	307	63
45 <sup>1)</sup>	M3BA 200 MLC	3GBA 202 033-••G	1479	93.6	94.4	94.2	0.83	83.6	7.5	290	2.9	3.2	0.366	319	63
55	M3BA 225 SMC	3GBA 222 033-••G	1478	94.0	94.7	94.5	0.85	99.3	7.4	355	2.9	3.1	0.474	370	66
73 <sup>1)2)</sup>	M3BA 225 SMD	3GBA 222 034-••G	1474	93.6	94.6	94.4	0.85	132	7.1	472	2.9	2.9	0.542	399	66
75 <sup>1)</sup>	M3BA 250 SMB	3GBA 252 032-••G	1478	94.4	95.1	94.9	0.85	134	7.3	484	2.8	3.1	0.866	450	67
90 <sup>1)</sup>	M3BA 250 SMC	3GBA 252 033-••G	1478	94.7	95.3	95.0	0.84	163	7.4	581	3.1	3.3	0.941	478	67

<sup>1)</sup> Temperature rise class F

<sup>2)</sup> Efficiency level IE1.

The bullets in the product code indicate choice of mounting arrangement, voltage and frequency, generation code (see ordering information page).

I<sub>s</sub> / I<sub>N</sub> = Starting current

T<sub>l</sub> / T<sub>N</sub> = Locked rotor torque

T<sub>b</sub> / T<sub>N</sub> = Breakdown torque

Efficiency values are given according to IEC 60034-2-1; 2007.

Please note that the values are not comparable without knowing the testing method.

ABB has calculated the efficiency values according to indirect method, stray load losses (additional losses) determined from measuring.

# Industrial performance cast iron motors

## Technical data for totally enclosed squirrel cage three phase motors

IE2

IP 55 - IC 411 - Insulation class F, temperature rise class B  
IE2 efficiency class according to IEC 60034-30; 2008

Output kW	Motor type	Product code	Speed r/min	Efficiency IEC 60034-2-1; 2007			Power factor cos φ	Current		Torque			Moment of inertia J = 1/4 GD <sup>2</sup> kgm <sup>2</sup>	Weight kg	Sound pressure level L <sub>PA</sub> dB
				Full load 100%	3/4 load 75%	1/2 load 50%		I <sub>N</sub> A	I <sub>s</sub> / I <sub>N</sub>	T <sub>N</sub> Nm	T <sub>l</sub> / T <sub>N</sub>	T <sub>b</sub> / T <sub>N</sub>			
<b>1000 r/min = 6-poles 400 V 50 Hz</b>			<b>CENELEC-design</b>												
0.18	M3BA 71 A	3GBA 073 321-••B	900	63.7	63.8	59.0	0.71	0.57	3.1	1.9	2.0	2.1	0.00089	10	42
0.25	M3BA 71 B	3GBA 073 322-••B	895	67.2	67.2	62.6	0.69	0.77	3.4	2.6	2.2	2.3	0.0011	12	42
0.37	M3BA 80 A	3GBA 083 321-••B	915	71.0	71.1	67.0	0.69	1.09	3.6	3.8	1.8	2.2	0.00187	15	47
0.55	M3BA 80 B	3GBA 083 322-••B	920	73.9	75.0	72.8	0.71	1.51	3.8	5.7	1.8	2.2	0.00239	17	47
0.75	M3BA 90 LB	3GBA 093 323-••B	960	78.7	77.3	72.5	0.58	2.3	4.5	7.4	2.3	3.1	0.00491	25	44
1.1	M3BA 90 LD	3GBA 093 324-••B	930	78.2	78.6	76.4	0.66	3	4.0	11.2	1.9	2.3	0.0054	28	44
1.5	M3BA 100 L	3GBA 103 322-••B	950	82.2	82.9	81.6	0.69	3.8	4.0	15	1.5	1.1	0.00873	37	49
2.2	M3BA 112 MB	3GBA 113 322-••B	950	82.5	83.8	81.7	0.69	5.5	4.4	22.1	1.7	2.3	0.0125	44	66
3	M3BA 132 MA	3GBA 133 321-••B	975	85.8	84.8	81.9	0.60	8.4	5.5	29.3	1.7	2.9	0.03336	69	57
4	M3BA 132 MA	3GBA 133 322-••B	960	84.9	85.3	83.9	0.68	10	4.6	39.7	1.5	2.2	0.03336	69	57
5.5	M3BA 132 MC	3GBA 133 324-••B	965	86.1	86.6	85.5	0.71	12.9	5.1	54.4	2.0	2.3	0.0487	86	57
7.5	M3BA 160 MLA	3GBA 163 031-••G	975	88.6	89.9	89.7	0.79	15.4	7.4	73.4	1.7	3.2	0.087	134	59
11	M3BA 160 MLB	3GBA 163 032-••G	972	89.3	90.7	90.6	0.79	22.5	7.5	108	1.9	2.9	0.114	172	59
15	M3BA 180 MLA	3GBA 183 031-••G	981	90.5	91.4	91.0	0.77	31	6.5	146	1.8	2.8	0.192	221	59
18.5	M3BA 200 MLA	3GBA 203 031-••G	988	91.6	92.3	91.7	0.80	36.4	6.7	178	2.3	2.9	0.382	269	63
22	M3BA 200 MLB	3GBA 203 032-••G	987	92.0	93.0	92.8	0.82	42	6.6	212	2.2	2.8	0.448	291	63
30	M3BA 225 SMA	3GBA 223 031-••G	986	92.7	93.3	92.9	0.83	56.2	7.0	290	2.6	2.9	0.663	349	63
37	M3BA 250 SMA	3GBA 253 031-••G	989	93.1	93.8	93.4	0.82	69.9	6.8	357	2.4	2.7	1.13	395	63
<b>1000 r/min = 6-poles 400 V 50 Hz</b>			<b>High-output design</b>												
15	M3BA 160 MLC	3GBA 163 033-••G	967	88.7	90.5	90.5	0.76	32.1	6.3	148	2.0	2.9	0.131	185	59
18.5	M3BA 180 MLB	3GBA 183 032-••G	970	88.8	90.7	90.7	0.75	40	5.1	182	1.6	2.5	0.213	234	59
30	M3BA 200 MLC	3GBA 203 033-••G	985	92.0	93.1	92.9	0.83	56.7	6.9	290	2.3	2.8	0.531	318	63
37	M3BA 225 SMB	3GBA 223 034-••G	985	93.1	94.0	94.0	0.83	69.1	6.6	358	2.3	2.6	0.821	393	63
45 <sup>1)</sup>	M3BA 225 SMC	3GBA 223 033-••G	984	92.7	93.9	94.0	0.83	84.4	6.4	436	2.3	2.6	0.821	393	63
45	M3BA 250 SMB	3GBA 253 032-••G	989	93.4	94.1	93.9	0.83	83.7	7.0	434	2.5	2.7	1.369	441	63
55 <sup>1)</sup>	M3BA 250 SMC	3GBA 253 033-••G	988	93.2	94.1	94.0	0.84	101	7.1	531	2.6	2.8	1.5	468	63

<sup>1)</sup> Temperature rise class F

The bullets in the product code indicate choice of mounting arrangement, voltage and frequency, generation code (see ordering information page).

I<sub>s</sub> / I<sub>N</sub> = Starting current  
T<sub>l</sub> / T<sub>N</sub> = Locked rotor torque  
T<sub>b</sub> / T<sub>N</sub> = Breakdown torque

Efficiency values are given according to IEC 60034-2-1; 2007.

Please note that the values are not comparable without knowing the testing method.

ABB has calculated the efficiency values according to indirect method, stray load losses (additional losses) determined from measuring.

# Industrial performance cast iron motors

## Technical data for totally enclosed squirrel cage three phase motors

IP 55 - IC 411 - Insulation class F, temperature rise class B  
IE2 efficiency class according to IEC 60034-30; 2008

Output kW	Motor type	Product code	Speed r/min	Efficiency IEC 60034-2-1; 2007			Power factor cos φ	Current		Torque			Moment of inertia J = 1/4 GD <sup>2</sup> kgm <sup>2</sup>	Weight kg	Sound pressure level L <sub>PA</sub> dB
				Full load 100%	3/4 load 75%	1/2 load 50%		I <sub>N</sub> A	I <sub>s</sub> / I <sub>N</sub>	T <sub>N</sub> Nm	T <sub>l</sub> / T <sub>N</sub>	T <sub>b</sub> / T <sub>N</sub>			
<b>750 r/min = 8-poles 400 V 50 Hz</b>			<b>GENELEC-design</b>												
0.09	M3BA 71 A	3GBA 074 101-••B	660	49.4	46.0	38.5	0.59	0.44	2.0	1.3	2.4	2.3	0.00089	11	40
0.12	M3BA 71 B	3GBA 074 102-••B	670	51.4	47.5	39.9	0.56	0.6	2.1	1.71	2.8	2.4	0.0011	12	43
0.18	M3BA 80 A	3GBA 084 101-••B	685	63.5	62.0	56.3	0.62	0.65	2.8	2.5	1.6	2.0	0.00187	15	45
0.25	M3BA 80 B	3GBA 084 102-••B	685	67.1	67.2	63.4	0.63	0.85	2.8	3.4	1.4	1.9	0.00187	17	50
0.37	M3BA 90 L	3GBA 094 102-••B	705	66.3	64.0	57.1	0.54	1.49	2.8	5	1.4	2.2	0.00444	24	50
0.55	M3BA 90 LB	3GBA 094 103-••B	655	61.8	65.6	65.2	0.67	1.91	2.3	8	1.1	1.5	0.00491	25	53
0.75	M3BA 100 LA	3GBA 104 101-••B	720	70.7	67.1	59.9	0.47	3.2	3.9	9.9	2.8	3.6	0.0072	30	46
1.1	M3BA 100 LB	3GBA 104 102-••B	695	76.0	76.5	74.6	0.66	3.1	3.4	15.1	1.7	2.2	0.00871	30	53
1.5	M3BA 112 M	3GBA 114 101-••B	690	74.4	75.9	74.1	0.70	4.1	3.2	20.7	1.4	1.9	0.0106	39	55
2.2	M3BA 132 S	3GBA 134 101-••B	715	82.9	83.0	80.8	0.62	6.1	3.4	29.3	1.3	1.9	0.03336	70	56
3	M3BA 132 M	3GBA 134 102-••B	715	79.9	80.8	79.1	0.64	8.4	3.2	40	1.2	1.8	0.04003	75	58
4	M3BA 160 MLA	3GBA 164 031-••G	728	84.1	85.1	83.7	0.67	10.2	5.4	52.4	1.5	2.6	0.068	120	59
5.5	M3BA 160 MLB	3GBA 164 032-••G	726	84.7	86.0	84.9	0.67	13.9	5.6	72.3	1.4	2.6	0.085	134	59
7.5	M3BA 160 MLC	3GBA 164 033-••G	727	86.1	87.3	86.6	0.65	19.3	4.7	98.5	1.5	2.8	0.132	184	59
11	M3BA 180 MLA	3GBA 184 031-••G	731	86.8	88.4	87.8	0.67	27.3	4.4	143	1.8	2.6	0.214	233	59
15	M3BA 200 MLA	3GBA 204 031-••G	737	90.2	91.3	90.9	0.74	32.4	5.3	194	2.0	2.4	0.45	290	60
18.5	M3BA 225 SMA	3GBA 224 031-••G	739	91.0	92.0	91.5	0.73	40.1	5.2	239	2.0	2.3	0.669	350	63
22	M3BA 225 SMB	3GBA 224 032-••G	738	91.6	92.4	92.0	0.74	46.8	5.5	284	2.0	2.3	0.722	363	63
30	M3BA 250 SMA	3GBA 254 031-••G	742	92.4	92.9	92.3	0.71	66	5.8	386	2.6	2.4	1.404	440	63

The bullets in the product code indicate choice of mounting arrangement, voltage and frequency, generation code (see ordering information page).

I<sub>s</sub> / I<sub>N</sub> = Starting current  
T<sub>l</sub> / T<sub>N</sub> = Locked rotor torque  
T<sub>b</sub> / T<sub>N</sub> = Breakdown torque

Efficiency values are given according to IEC 60034-2-1; 2007.

Please note that the values are not comparable without knowing the testing method.

ABB has calculated the efficiency values according to indirect method, stray load losses (additional losses) determined from measuring.

# Industrial performance cast iron motors – variant codes

Code <sup>1)</sup>	Variant	Frame Size										
		71	80	90	100	112	132	160	180	200	225	250
<b>Balancing</b>												
417	Vibration acc. to Grade B (IEC 60034-14).	P	P	P	P	P	P	P	P	P	P	P
423	Balanced without key.	P	P	P	P	P	P	P	P	P	P	P
424	Full key balancing.	P	P	P	P	P	P	P	P	P	P	P
<b>Bearings and Lubrication</b>												
036	Transport lock for bearings.	NA	NA	NA	NA	NA	NA	M	M	M	M	M
037	Roller bearing at D-end.	NA	NA	NA	NA	NA	NA	M	M	M	M	M
039	Cold resistant grease.	M	M	M	M	M	M	NA	NA	NA	NA	NA
040	Heat resistant grease.	M	M	M	M	M	M	NA	NA	NA	NA	NA
041	Bearings regreasable via grease nipples.	NA	NA	NA	NA	NA	NA	M	M	M	M	M
043	SPM compatible nipples for vibration measurement	P	P	P	P	P	P	M	M	M	M	M
057	2RS bearings at both ends.	M	M	M	M	M	M	M	M	M	M	M
058	Angular contact bearing at D-end, shaft force away from bearing.	NA	NA	NA	NA	NA	NA	M	M	M	M	M
059	Angular contact bearing at N-end, shaft force towards bearing.	NA	NA	NA	NA	NA	NA	M	M	M	M	M
796	Grease nipples JIS B 1575 PT 1/8 Type A	NA	NA	NA	NA	NA	NA	M	M	M	M	M
797	Stainless steel SPM Nipples	NA	NA	NA	NA	NA	NA	M	M	M	M	M
798	Stainless steel grease nipples	NA	NA	NA	NA	NA	NA	M	M	M	M	M
<b>Branch standard designs</b>												
071	Cooling Tower duty	NA	NA	NA	NA	NA	NA	P	P	P	P	P
079	Silumin-alloy rotor cage.	P	P	P	P	P	P	NA	NA	NA	NA	NA
142	„Manilla connection“.	NA	NA	NA	NA	NA	NA	P	P	P	P	P
178	Stainless steel / acid proof bolts.	M	M	M	M	M	M	M	M	M	M	M
199	Extreme heavy duty design.	NA	NA	NA	NA	NA	NA	R	R	R	R	R
209	Non-standard voltage or frequency, (special winding).	P	P	P	P	P	P	P	P	P	P	P
425	Corrosion protected stator and rotor core.	P	P	P	P	P	P	P	P	P	P	P
<b>Cooling system</b>												
068	Light alloy metal fan	NA	NA	NA	NA	NA	NA	M	M	M	M	M
075	Cooling method IC418 (without fan).	P	P	P	P	P	P	M	M	M	M	M
183	Separate motor cooling (fan axial, N-end).	NA	NA	NA	NA	NA	NA	M	M	M	M	M
189	Separate motor cooling, IP44, 400V, 50Hz (fan axial, N-end).	NA	NA	NA	NA	NA	NA	M	M	M	M	M
794	Fan for reduced noise level (4-p fan).	NA	NA	NA	NA	NA	NA	R	R	R	R	R
<b>Documentation</b>												
141	Binding dimension drawing.	M	M	M	M	M	M	M	M	M	M	M
<b>Drain holes</b>												
65	Plugged existing drain holes.	NA	NA	NA	NA	NA	NA	M	M	M	M	M
<b>Earthing Bolt</b>												
67	External earthing bolt.	M	M	M	M	M	M	M	M	M	M	M
<b>Hazardous Environments</b>												
See catalog „Motors for hazardous environments“ for details.												
<b>Heating elements</b>												
450	Heating element, 100-120V.	M	M	M	M	M	M	M	M	M	M	M
451	Heating element, 200-240V.	M	M	M	M	M	M	M	M	M	M	M
<b>Insulation system</b>												
014	Winding insulation class H.	NA	NA	NA	NA	NA	NA	P	P	P	P	P
405	Special winding insulation for frequency converter supply.	NA	NA	NA	NA	NA	NA	P	P	P	P	P

<sup>1)</sup> Certain variant codes cannot be used simultaneously.

S = Included as standard.

M = On modification of a stocked motor,  
or on new manufacture,  
the number per order may be limited.

P = New manufacture only.

R = On request.

NA = Not applicable.

Code <sup>1)</sup>	Variant	Frame Size										
		71	80	90	100	112	132	160	180	200	225	250
<b>Mounting arrangements</b>												
008	IM 2101 foot/flange mounted, IEC flange, from IM 1001 (B34 from B3).	M	M	M	M	M	M	M	NA	NA	NA	NA
009	IM 2001 foot/flange mounted, IEC flange, from IM 1001 (B35 from B3).	M	M	M	M	M	M	M	M	M	M	M
047	IM 3601 flange mounted, IEC flange, from IM 3001 (B14 from B5).	M	M	M	M	M	M	M	NA	NA	NA	NA
066	Modified for non-standard mounting position (please specify IM xxxx), (must be ordered for all mounting arrangements excluding IM B3 (1001), IM B5 (3001), IM B35 (2001), B34 (2101) & B14 (3601).	M	M	M	M	M	M	M	M	M	M	M
<b>Painting</b>												
114	Special paint colour, standard grade.	M	M	M	M	M	M	M	M	M	M	M
179	Special paint specification.	NA	NA	NA	NA	NA	NA	R	R	R	R	R
<b>Protection</b>												
005	Metal protective roof, vertical motor, shaft down.	M	M	M	M	M	M	M	M	M	M	M
072	Radial seal at D-end.	NA	NA	NA	NA	NA	NA	M	M	M	M	M
158	Degree of protection IP65.	M	M	M	M	M	M	M	M	M	M	M
211	Weather protected, IP xx W	M	M	M	M	M	M	M	M	M	M	M
403	Degree of protection IP56.	M	M	M	M	M	M	M	M	M	M	M
784	Gamma-seal at D-end.	M	M	M	M	M	M	M	M	M	M	M
<b>Rating &amp; instruction plates</b>												
002	Restamping voltage, frequency and output, continuous duty.	M	M	M	M	M	M	M	M	M	M	M
004	Additional text on std rating plate (max 12 digits on free text line).	NA	NA	NA	NA	NA	NA	M	M	M	M	M
095	Restamping output (maintained voltage, frequency), intermittent duty.	M	M	M	M	M	M	M	M	M	M	M
098	Stainless rating plate.	M	M	M	M	M	M	S	S	S	S	S
135	Mounting of additional identification plate, stainless.	M	M	M	M	M	M	NA	NA	NA	NA	NA
138	Mounting of additional identification plate, aluminium.	M	M	M	M	M	M	M	M	M	M	M
139	Additional identification plate delivered loose.	M	M	M	M	M	M	M	M	M	M	M
160	Additional rating plate affixed.	M	M	M	M	M	M	M	M	M	M	M
161	Additional rating plate delivered loose.	M	M	M	M	M	M	M	M	M	M	M
163	Frequency converter rating plate. Rating data according to quotation.	P	P	P	P	P	P	M	M	M	M	M
<b>Shaft &amp; rotor</b>												
069	Two shaft extensions as per basic catalogue.	NA	NA	NA	NA	NA	NA	P	P	P	P	P
070	One or two special shaft extensions, standard shaft material.	P	P	P	P	P	P	R	R	R	R	R
131	Motor delivered with half key (Key not exceeding shaft diameter)	NA	NA	NA	NA	NA	NA	M	M	M	M	M
165	Shaft extension with open key-way.	NA	NA	NA	NA	NA	NA	P	P	P	P	P
410	Stainless steel shaft (standard or non-standard design).	P	P	P	P	P	P	P	P	P	P	P
<b>Standards and Regulations</b>												
010	Fulfilling CSA Safety Certificate.	NA	NA	NA	NA	NA	NA	M	M	M	M	M
011	Fulfilling CSA Energy Efficiency Verification (code 010 included).	NA	NA	NA	NA	NA	NA	M	M	M	M	M
500	Fulfilling Korean MEPS efficiency regulations	NA	NA	NA	NA	NA	NA	R	R	R	R	R
540	China energy label	NA	NA	NA	NA	NA	NA	R	R	R	R	R
778	GOST Export/Import Certificate (Russia).	NA	NA	NA	NA	NA	NA	M	M	M	M	M
779	SASO Export/Import Certificate (Saudi Arabia)	NA	NA	NA	NA	NA	NA	M	M	M	M	M

<sup>1)</sup> Certain variant codes cannot be used simultaneously.

S = Included as standard.

M = On modification of a stocked motor, or on new manufacture, the number per order may be limited.

P = New manufacture only.

R = On request.

NA = Not applicable.

Code <sup>1)</sup>	Variant	Frame Size										
		71	80	90	100	112	132	160	180	200	225	250
<b>Stator winding temperature sensors</b>												
121	Bimetal detectors, break type (NCC), (3 in series), 130°C, in stator winding.	M	M	M	M	M	M	M	M	M	M	M
122	Bimetal detectors, break type (NCC), (3 in series), 150°C, in stator winding.	M	M	M	M	M	M	M	M	M	M	M
123	Bimetal detectors, break type (NCC), (3 in series), 170°C, in stator winding.	NA	NA	NA	NA	NA	NA	M	M	M	M	M
124	Bimetal detectors, break type (NCC), (3 in series), 140°C, in stator winding.	NA	NA	NA	NA	NA	NA	M	M	M	M	M
125	Bimetal detectors, break type (NCC), (2x3 in series), 150°C, in stator winding.	NA	NA	NA	NA	NA	NA	M	M	M	M	M
127	Bimetal detectors, break type (NCC), (3 in series), 130°C & 3 in series, 150°C), in stator winding.	NA	NA	NA	NA	NA	NA	M	M	M	M	M
435	PTC - thermistors (3 in series), 130°C, in stator winding.	M	M	M	M	M	M	M	M	M	M	M
437	PTC - thermistors (3 in series), 170°C, in stator winding.	M	M	M	M	M	M	M	M	M	M	M
439	PTC - thermistors (2x3 in series), 150°C, in stator winding.	M	M	M	M	M	M	M	M	M	M	M
441	PTC - thermistors (3 in series, 130°C & 3 in series, 150°C), in stator winding.	M	M	M	M	M	M	M	M	M	M	M
442	PTC - thermistors (3 in series, 150°C & 3 in series, 170°C), in stator winding.	M	M	M	M	M	M	M	M	M	M	M
445	Pt-100 2-wire in stator winding, 1 per phase	NA	NA	NA	NA	NA	NA	M	M	M	M	M
446	Pt-100 2-wire in stator winding, 2 per phase	NA	NA	NA	NA	NA	NA	M	M	M	M	M
<b>Terminal box</b>												
015	Motor supplied in D connection.	NA	NA	NA	NA	NA	NA	M	M	M	M	M
017	Motor supplied in Y connection.	NA	NA	NA	NA	NA	NA	M	M	M	M	M
021	Terminal box LHS (seen from D-end).	M	M	M	M	M	M	P	P	P	P	P
180	Terminal box RHS (seen from D-end).	M	M	M	M	M	M	P	P	P	P	P
230	Standard metal cable glands.	M	M	M	M	M	M	M	M	M	M	M
375	Standard plastic cable gland	M	M	M	M	M	M	NA	NA	NA	NA	NA
418	Separate terminal box for auxiliaries, standard material.	NA	NA	NA	NA	NA	NA	M	M	M	M	M
467	Lower than standard terminal box and rubber extended cable. Cable length 2m.	NA	NA	NA	NA	NA	NA	P	P	P	P	P
731	Two standard metal cable glands.	M	M	M	M	M	M	M	M	M	M	M
739	Prepared for metric cable glands according to DIN 42925, draft aug. 1999.	NA	NA	NA	NA	NA	NA	NA	NA	M	M	M
740	Prepared for PG cable glands.	NA	NA	NA	NA	NA	NA	M	M	M	M	M
<b>Testing</b>												
140	Test confirmation.	M	M	M	M	M	M	M	M	M	M	M
145	Type test report from a catalogue motor, 400V 50Hz.	M	M	M	M	M	M	M	M	M	M	M
146	Type test with report for one motor from specific delivery batch.	M	M	M	M	M	M	M	M	M	M	M
147	Type test with report for motor from specific delivery batch, customer witnessed.	M	M	M	M	M	M	M	M	M	M	M
148	Routine test report.	M	M	M	M	M	M	M	M	M	M	M
149	Test according to separate test specification.	R	R	R	R	R	R	R	R	R	R	R
153	Reduced test for classification society.	M	M	M	M	M	M	M	M	M	M	M
221	Type test and multi-point load test with report for one motor from specific delivery batch.	M	M	M	M	M	M	M	M	M	M	M
222	Torque/speed curve, type test and multi-point load test with report for one motor from specific delivery batch.	M	M	M	M	M	M	M	M	M	M	M
760	Vibration level test	M	M	M	M	M	M	M	M	M	M	M
762	Noise level test for one motor from specific delivery batch.	M	M	M	M	M	M	M	M	M	M	M

<sup>1)</sup> Certain variant codes cannot be used simultaneously.

S = Included as standard.

M = On modification of a stocked motor, or on new manufacture, the number per order may be limited.

P = New manufacture only.

R = On request.

NA = Not applicable.

Code <sup>1)</sup>	Variant	Frame Size										
		71	80	90	100	112	132	160	180	200	225	250
<b>Variable speed drives</b>												
470	Prepared for hollow shaft pulse tacho (L&L equivalent).	NA	NA	NA	NA	NA	NA	M	M	M	M	M
472	1024 pulse tacho (L&L 861007455-1024).	NA	NA	NA	NA	NA	NA	M	M	M	M	M
473	2048 pulse tacho (L&L 861007455-2048).	NA	NA	NA	NA	NA	NA	M	M	M	M	M
474	Separate motor cooling (fan axial, N-end) and prepared for hollow shaft tacho (L&L equivalent).	NA	NA	NA	NA	NA	NA	M	M	M	M	M
476	Separate motor cooling (fan axial, N-end) and 1024 pulse tacho (L&L 861007455-1024).	NA	NA	NA	NA	NA	NA	M	M	M	M	M
477	Separate motor cooling (fan axial, N-end) and 2048 pulse tacho (L&L 861007455-2048).	NA	NA	NA	NA	NA	NA	M	M	M	M	M
570	Prepared for hollow shaft pulse tacho (L&L 503).	NA	NA	NA	NA	NA	NA	M	M	M	M	M
572	1024 pulse tacho (L&L 503).	NA	NA	NA	NA	NA	NA	M	M	M	M	M
573	2048 pulse tacho (L&L 503).	NA	NA	NA	NA	NA	NA	M	M	M	M	M
574	Separate motor cooling (fan axial, N-end) and prepared for hollow shaft tacho (L&L 503).	NA	NA	NA	NA	NA	NA	M	M	M	M	M
576	Separate motor cooling (fan axial, N-end) and 1024 pulse tacho (L&L 503).	NA	NA	NA	NA	NA	NA	M	M	M	M	M
577	Separate motor cooling (fan axial, N-end) and 2048 pulse tacho (L&L 503).	NA	NA	NA	NA	NA	NA	M	M	M	M	M
580	Separate motor cooling, IP44, 400V, 50Hz (fan axial, N-end) and 1024 pulse tacho (L&L 503).	NA	NA	NA	NA	NA	NA	M	M	M	M	M
581	Separate motor cooling, IP44, 400V, 50Hz (fan axial, N-end) and 2048 pulse tacho (L&L 503).	NA	NA	NA	NA	NA	NA	M	M	M	M	M
701	Insulated bearing at N-end.	NA	NA	NA	NA	NA	NA	P	P	M	M	M
704	EMC cable gland.	NA	NA	NA	NA	NA	NA	M	M	M	M	M
<b>Y/Δ starting</b>												
117	Terminals for Y/Δ start at both speeds (two speed windings).	NA	NA	NA	NA	NA	NA	P	P	P	P	P

<sup>1)</sup> Certain variant codes cannot be used simultaneously.

S = Included as standard.

M = On modification of a stocked motor, or on new manufacture, the number per order may be limited.

P = New manufacture only.

R = On request.

NA = Not applicable.

# Industrial performance cast iron motors

## Dimension drawings

M3BA 71 - 132

### Foot-mounted motor; IM B3 (IM 1001), IM 1002

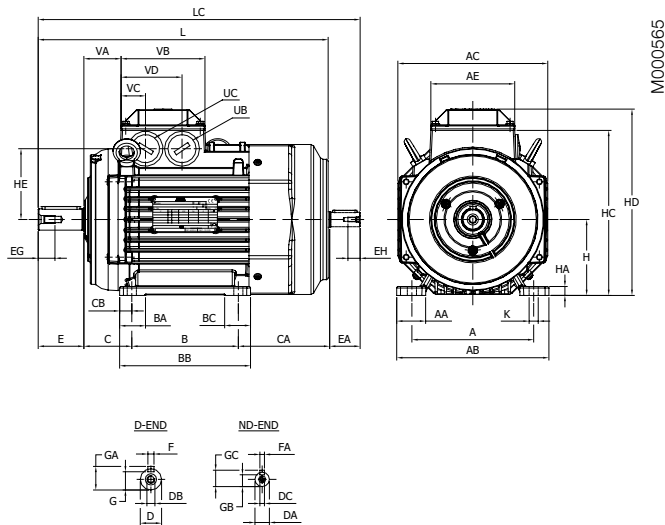

### Flange-mounted motor, large flange; IM B5 (IM 3001), IM 3002

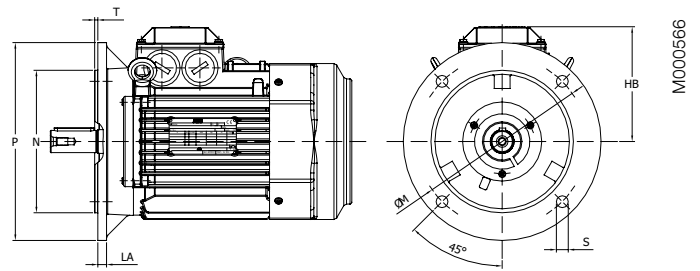

### Flange-mounted motor, small flange; IM B14 (IM 3601)

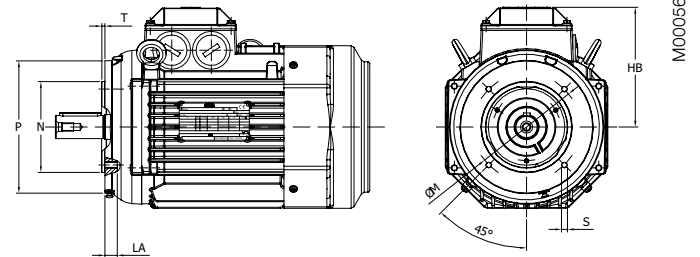

### IM B3 (IM 1001), IM 1002

Motor size	A	AA	AB	AC	AE	AF	B	BA	BB	BC	C	CA	CB	D-Tol.	DA	DB	DC	E	EA	EG	EH
71	112	24	136	139	97	139	90	24	110	24	45	104	10	14-j6	11	M5	M4	30	23	12.5	10
80	125	28	154	157	97	157	100	28	125	28	50	136	12.5	19-j6	14	M6	M5	40	30	16	12.5
90S	140	30	170	177	110	177	100	30	150	55	56	156.5	12.5	24-j6	14	M8	M5	50	30	19	12.5
90L	140	30	170	177	110	177	125	30	150	55	56	131.5	12.5	24-j6	14	M8	M5	50	30	19	12.5
100	160	38	200	197	110	197	140	34	172	34	63	123	16	28-j6	19	M10	M6	60	40	22	16
112	190	41	230	197	110	197	140	34	172	34	70	138	16	28-j6	19	M10	M6	60	40	22	16
132S	216	47	262	261	160	261	140	40	212	76	89	228	16	38-k6	24	M12	M8	80	50	28	19
132M	216	47	262	261	160	261	178	40	212	76	89	190	16	38-k6	24	M12	M8	80	50	28	19

Motor size	F	FA	G	GA	GB	GC	H	HA	HC	HD	HE	K	L	LC	UB	UC	VA	VB	VC	VD
71	5	4	11	16	8.5	12.5	71	9	151	178	62	7	264	292	M16x1.5	M16x1.5	30	105	31.5	73.5
80	6	5	15.5	21.5	11	16	80	10	168	195	69	10	321	356	M25x1.5	M25x1.5	32	105	32	74
90	8	5	20	27	11	16	90	11	189	219	79	10	357	392	M25x1.5	M25x1.5	42	118	39	81
100	8	6	24	31	15.5	21.5	100	12	217	247	94	12	381	426	M32x1.5	M32x1.5	45	118	36	84
112	8	6	24	31	15.5	21.5	112	12	229	259	94	12	403	448	M32x1.5	M32x1.5	45	118	36	84
132	10	8	33	41	20	27	132	14	272	300	116	12	533	588	M32x1.5	M32x1.5	65	169	82	130

### IM B5 (IM3001), IM 3002

Motor size	HB	LA	M	N	P	S	T
71	107.5	9	130	110	160	10	3.5
80	115.5	10	165	130	200	12	3.5
90	129.5	10	165	130	200	12	3.5
100	147.5	11	215	180	250	15	4
112	147.5	11	215	180	250	15	4
132	168	12.5	265	230	300	15	4

### IM B14 (IM3601), IM 3602

Motor size	HB	LA	M	N	P	S	T
71	107.5	8	85	70	105	M6	2.5
80	115.5	8	100	80	120	M6	3
90	129.5	10	115	95	140	M8	3
100	147.5	10	130	110	160	M8	3.5
112	147.5	10	130	110	160	M8	3.5
132	168	12	165	130	200	M10	3.5

#### Tolerances:

A, B	+ - 0.8	H	+0 -0.5
D, DA	ISO j6	N	ISO j6
F, FA	ISO h9	C, CA	+ - 0.8

Above table gives the main dimensions in mm.  
For detailed drawings please see our web-pages '[www.abb.com/motors&generators](http://www.abb.com/motors&generators)' or contact ABB.





# Industrial performance cast iron motors

## Dimension drawings

# M3BA 160 - 250

Foot-mounted: IM B3 (IM 1001), IM B6 (IM 1051), IM B7 (IM 1061), IM B8 (IM 1071), IM V5 (IM 1011), IM V6 (IM 1031)

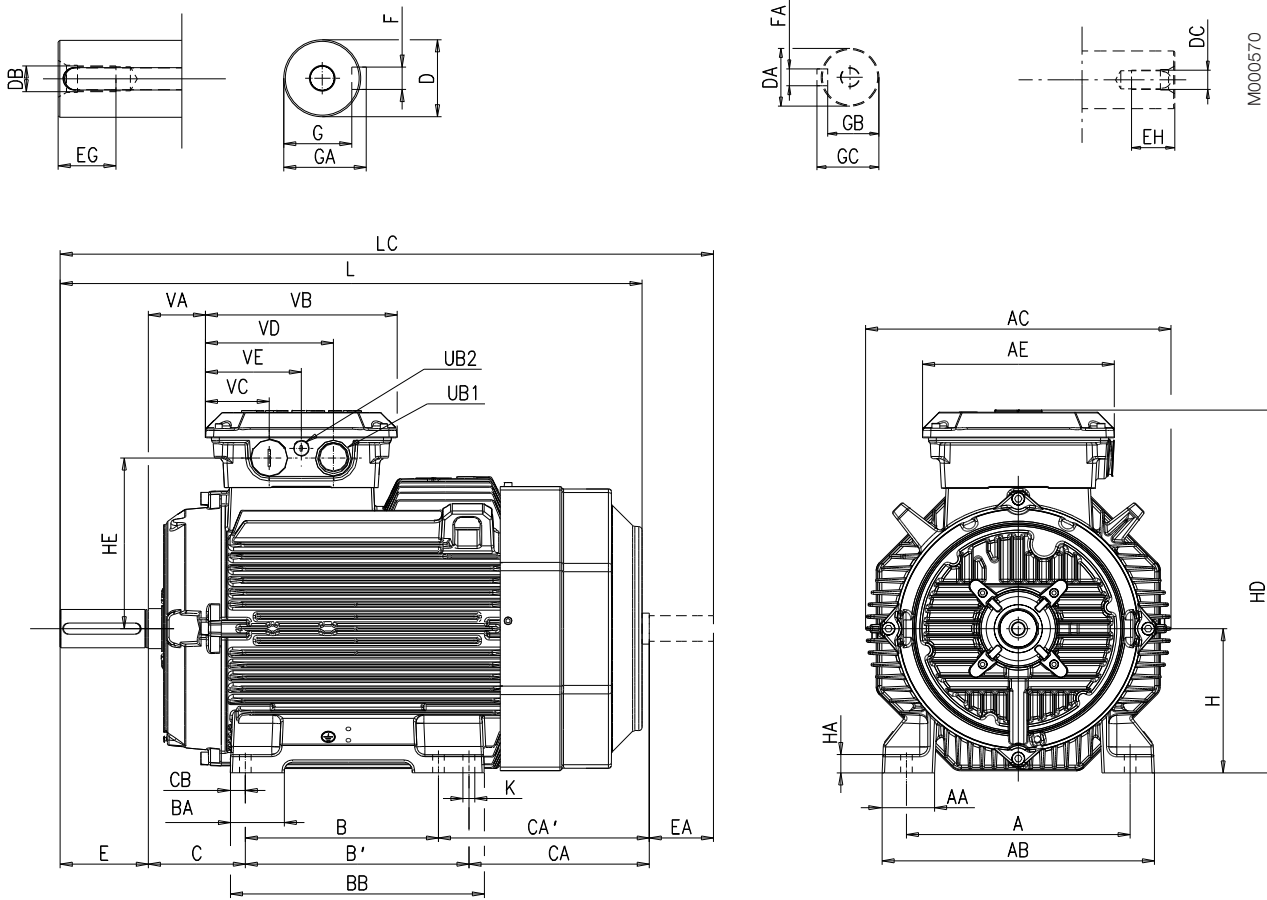

M000570

Motor size	Poles	A	AA	AB	AC	AE	B	B'	BA	BB	C	CA	CA'	CB	D	DA	DB	DC	E	EA	EG	EH
160 <sup>1)</sup>	2-8	254	67	310	338	239	210	254	69	294	108	163.5	125.5	20	42	32	M16	M12	110	80	36	28
160 <sup>2)</sup>	2-8	254	67	310	338	239	210	254	69	294	108	261.5	223.5	20	42	32	M16	M12	110	80	36	28
180	2-8	279	67	340	381	239	241	279	68	318	121	263	225	30	48	32	M16	M12	110	80	36	28
200	2-8	318	69	378	413	257	267	305	80	345	133	314	276	30	55	45	M20	M16	110	110	42	36
225	2	356	84	435	460	257	286	311	69	351	149	314	289	24.5	55	55	M20	M20	110	110	42	42
225	4-8	356	84	435	460	257	286	311	69	351	149	314	289	24.5	60	55	M20	M20	140	110	42	42
250	2	406	92	480	508	257	311	349	69	392	168	281	243	40	60	55	M20	M20	140	110	42	42
250	4-8	406	92	480	508	257	311	349	69	392	168	281	243	30	65	55	M20	M20	140	110	42	42

Motor size	Poles	F	FA	G	GA	GB	GC	H	HA	HD	HE	K	L	LC	UB1	UB2	VA	VB	VC	VD	VE
160 <sup>1)</sup>	2-8	12	10	37	45	27	35	160	23	413	193	14.5	584	671.5	2*M40	M16	58	239	80	160	120
160 <sup>2)</sup>	2-8	12	10	37	45	27	35	160	23	413	193	14.5	681	768.5	2*M40	M16	58	239	80	160	120
180	2-8	14	10	42.5	51.5	27	35	180	23	453	213	14.5	726	815	2*M40	M16	71	239	80	160	120
200	2-8	16	14	49	59	39.5	48.5	200	23	514	241	18	822	934	2*M63	M16	82	257	81	177	129
225	2	16	16	49	59	49	59	225	23	559	261	18	850	971	2*M63	M16	75	257	81	177	129
225	4-8	18	16	53	64	49	59	225	23	559	261	18	880	1001	2*M63	M16	75	257	81	177	129
250	2	18	16	53	64	49	59	250	23	612	289	24	884	1010	2*M63	M16	75	257	81	177	129
250	4-8	18	16	58	69	49	59	250	23	612	289	24	884	1010	2*M63	M16	75	257	81	177	129

Tolerances:

- A, B ISO js14
- C, CA ± 0,8
- D, DA ISO k6 < Ø 50mm  
ISO m6 > Ø 50mm
- F, FA ISO h9
- H +0 -0,5

<sup>1)</sup> MLA-2, MLB-2, MLC-2, MLE-2, MLD-2, MLC-4, MLD-4, MLC-6 and MLC-8 poles

<sup>2)</sup> MLC-2, MLD-2, MLE-2, MLC-4, MLD-4, MLC-6 and MLC-8 poles

Above table gives the main dimensions in mm. For detailed drawings please see our web-pages 'www.abb.com/motors&generators' or contact ABB.

# Industrial performance cast iron motors

## Dimension drawings

# M3BA 160 - 250

Flange-mounted; IM B5 (IM 3001) , V1 (IM 3011), V3 (IM 3031) and IM B14 (IM 3601), V18 (IM 3611), V19 (IM 3631)

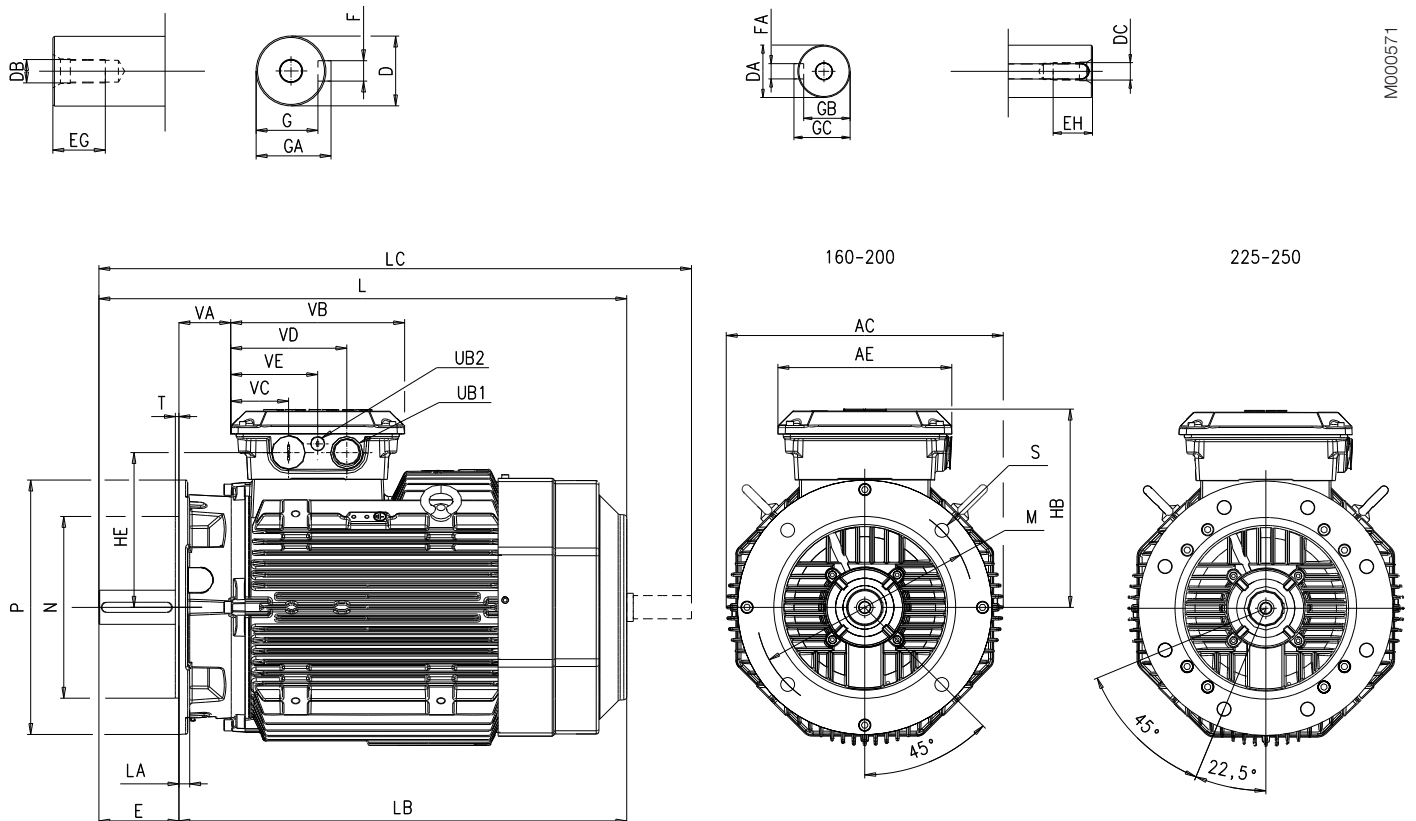

M000571

Motor size	Poles	AC	AE	D	DA	DB	DC	E	EA	EG	EH	F	FA	G	GA	GB	GC	HB	HE
160 <sup>1)</sup>	2-8	338	239	42	32	M16	M12	110	80	36	28	12	10	37	45	27	35	253	193
160 <sup>2)</sup>	2-8	338	239	42	32	M16	M12	110	80	36	28	12	10	37	45	27	35	253	193
180	2-8	381	239	48	32	M16	M12	110	80	36	28	14	10	42.5	51.5	27	35	273	213
200	2-8	413	257	55	45	M20	M16	110	110	42	36	16	14	49	59	39.5	48.5	314	241
225	2	460	257	55	55	M20	M20	110	110	42	42	16	16	49	59	49	59	334	261
225	4-8	460	257	60	55	M20	M20	140	110	42	42	18	16	53	64	49	59	334	261
250	2	508	257	60	55	M20	M20	140	110	42	42	18	16	53	64	49	59	362	289
250	4-8	508	257	65	55	M20	M20	140	110	42	42	18	16	58	69	49	59	362	289

Motor size	Poles	L	LA	LB	LC	M	N	P	S	T	UB1	UB2	VA	VB	VC	VD	VE
160 <sup>1)</sup>	2-8	584	20	474	671.5	300	250	350	19	5	2*M40	M16	58	239	80	160	120
160 <sup>2)</sup>	2-8	681	20	571	768.5	300	250	350	19	5	2*M40	M16	58	239	80	160	120
180	2-8	726	15	616	815	300	250	350	19	5	2*M40	M16	71	239	80	160	120
200	2-8	822	20	712	934	350	300	400	19	5	2*M63	M16	82	257	81	177	129
225	2	850	20	740	971	400	350	450	19	5	2*M63	M16	75	257	81	177	129
225	4-8	880	20	740	1001	400	350	450	19	5	2*M63	M16	75	257	81	177	129
250	2	884	24	744	1010	500	450	550	19	5	2*M63	M16	75	257	81	177	129
250	4-8	884	24	744	1010	500	450	550	19	5	2*M63	M16	75	257	81	177	129

Tolerances:

D, DA ISO k6 < Ø 50mm  
ISO m6 > Ø 50mm

F, FA SO h9

N ISO j6

<sup>1)</sup> MLA-2, MLB-2, MLA-4, MLA-6, MLA-8 and MLB 8-poles

<sup>2)</sup> MLC-2, MLD-2, MLE-2, MLB-4, MLC-4, MLD-4, MLB-6, MLC-6 and MLC-8 poles

Above table gives the main dimensions in mm.  
For detailed drawings please see our web-pages '[www.abb.com/motors&generators](http://www.abb.com/motors&generators)' or contact ABB.

# Industrial performance cast iron motors

## Dimension drawings

# M3BA 160 - 250

Foot- and flange-mounted: IM B35 (IM 2001), IM V15 (IM 2011), IM V36 (IM 2031)

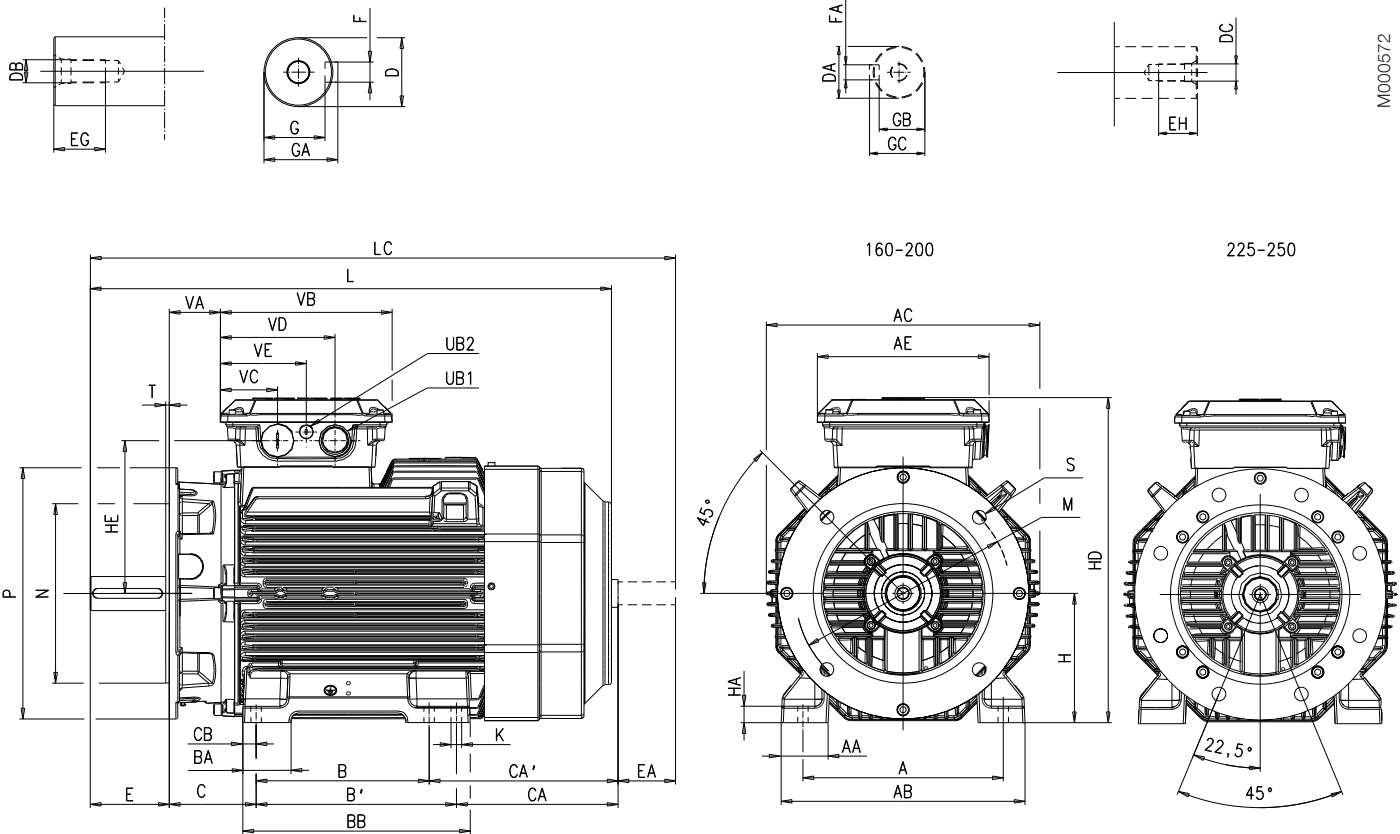

M000672

Motor size	Poles	A	AA	AB	AC	AE	B	B'	BA	BB	C	CA	CA'	CB	D	DA	DB	DC	E	EA	EG	EH	F	FA	G
160 <sup>1)</sup>	2-8	254	54	310	338	239	210	254	69	294	108	163.5	125.5	20	42	32	M16	M12	110	80	36	28	12	10	37
160 <sup>2)</sup>	2-8	254	54	310	338	239	210	254	69	294	108	261.5	223.5	20	42	32	M16	M12	110	80	36	28	12	10	37
180	2-8	279	68	340	381	239	241	279	68	318	121	263	225	30	48	32	M16	M12	110	80	36	28	14	10	42.5
200	2-8	318	69	378	413	257	267	305	80	345	133	314	276	30	55	45	M20	M16	110	110	42	36	16	14	49
225	2	356	84	435	460	257	286	311	69	365	149	314	289	24.5	55	55	M20	M20	110	110	42	42	16	16	49
225	4-8	356	84	435	460	257	286	311	69	365	149	314	289	24.5	60	55	M20	M20	140	110	42	42	18	16	53
250	2	406	92	480	508	257	311	349	69	392	168	281	243	40	60	55	M20	M20	140	110	42	42	18	16	53
250	4-8	406	92	480	508	257	311	349	69	392	168	281	243	30	65	55	M20	M20	140	110	42	42	18	16	58

Motor size	Poles	GA	GB	GC	H	HA	HD	HE	K	L	LA	LB	LC	M	N	P	S	T	UB1	UB2	VA	VB	VC	VD	VE
160 <sup>1)</sup>	2-8	45	27	35	160	23	413	193	14.5	584	20	474	671.5	300	250	350	19	5	2*M40	M16	58	239	80	160	120
160 <sup>2)</sup>	2-8	45	27	35	160	23	413	193	14.5	681	20	571	768.5	300	250	350	19	5	2*M40	M16	58	239	80	160	120
180	2-8	51.5	27	35	180	23	453	213	14.5	726	15	616	815	300	250	350	19	5	2*M40	M16	71	239	80	160	120
200	2-8	59	39.5	48.5	200	23	514	241	18	822	20	712	934	350	300	400	19	5	2*M63	M16	82	257	81	177	129
225	2	59	49	59	225	23	559	261	18	850	20	740	971	400	350	450	19	5	2*M63	M16	75	257	81	177	129
225	4-8	64	49	59	225	23	559	261	18	880	20	740	1001	400	350	450	19	5	2*M63	M16	75	257	81	177	129
250	2	64	49	59	250	23	612	289	24	884	24	744	1010	500	450	550	19	5	2*M63	M16	75	257	81	177	129
250	4-8	69	49	59	250	23	612	289	24	884	24	744	1010	500	450	550	19	5	2*M63	M16	75	257	81	177	129

Tolerances:

A, B ISO js14

C, CA ± 0,8

D, DA ISO k6 < Ø 50 mm  
ISO m6 > Ø 50 mm

F, FA ISO h9

H +0 -0,5

N ISO j6

<sup>1)</sup> MLA-2, MLB-2, MLA-4, MLA-6, MLA-8 and MLB 8-poles

<sup>2)</sup> MLC-2, MLD-2, MLE-2, MLB-4, MLC-4, MLD-4, MLB-6, MLC-6 and MLC-8 poles

Above table gives the main dimensions in mm. For detailed drawings please see our web-pages 'www.abb.com/motors&generators' or contact ABB.

# Industrial performance cast iron motors in brief

Motor size		71	80	90	100	112	132
<b>Stator</b>	Material	Cast iron EN-GJL-150/GG 15/GRS 150					
	Paint colour shade	Munsell blue 8B 4.5/3.25 / NCS 4822 B05G					
	Surface treatment	Two-pack epoxy-paint, $\geq 60\mu\text{m}$					
<b>Feet</b>		Cast iron EN-GJL-150/GG 15/GRS 150, intergrated with stator					
<b>Bearing end shields</b>	Material	Cast iron EN-GJL-150/GG 15/GRS 150					
	Paint colour shade	Munsell blue 8B 4.5/3.25 / NCS 4822 B05G					
	Surface treatment	Two-pack epoxy-paint, $\geq 60\mu\text{m}$					
<b>Bearings</b>	D-end	6203-2Z/C3	6204-2Z/C3	6205-2Z/C3	6206-2Z/C3	6206-2Z/C3	6208-2Z/C3
	N-end	6202-2Z/C3	6203-2Z/C3	6204-2Z/C3	6205-2Z/C3	6205-2Z/C3	6208-2Z/C3
<b>Axially-locked bearings</b>	Inner bearing cover	As standard, locked at D-end					
<b>Bearing seal</b>	D-end	V-ring					
	N-end	Labyrinth seal					
<b>Lubrication</b>		Permanently lubricated shielded bearings					
		Grease temperature range -40 to +160°C					
<b>Rating plate</b>	Material						
<b>Terminal box</b>	Material	Cast iron EN-GJL-150/GG 15/GRS 150					
	Surface treatment	Similar to stator					
	Screws	Steel 5G, coated with zinc and yellow chromated					
<b>Connections</b>	Threaded openings	2 x M16	2 x M25		2 x M32		
	Max Cu-area mm <sup>2</sup>	4	6		10		
	Terminals	Cable lugs, 6 terminals					
<b>Fan</b>	Material	Polypropylene. Reinforced with 20% glass fibre.					
<b>Fan cover</b>	Material	Steel					
	Paint colour shade	Blue, Munsell 8B 4.5/3.25 / NCS 4822 B05G					
	Surface treatment	Two-pack epoxy-paint, $\geq 60\mu\text{m}$					
<b>Stator winding</b>	Material	Copper					
	Insulation	Insulation class F. Temperature rise class B, unless otherwise stated.					
	Winding protection	3 PTC thermistors as standard, 150°C					
<b>Rotor winding</b>	Material	Pressure diecast aluminum					
<b>Balancing method</b>		Half key balancing as standard					
<b>Key ways</b>		Closed key way					
<b>Heating elements</b>	On request	8 W	25 W				
<b>Drain holes</b>		Drain holes with closable plastic plugs, open on delivery					
<b>Enclosure</b>		IP 55					
<b>Cooling method</b>		IC 411					

# Industrial performance cast iron motors in brief

Motor size		160	180	200	225	250
<b>Stator</b>	Material	Cast iron EN-GJL-200/GG 20/GRS 200				
	Paint colour shade	Blue, Munsell 8B 4.5/3.25 / NCS 4822 B05G				
	Corrosion class	C3 medium according to ISO/EN 12944-2				
<b>Feet</b>		Cast iron, intergrated with stator				
<b>Bearing end shields</b>	Material	Cast iron EN-GJL-200/GG 20/GRS 200				
	Paint colour shade	Blue, Munsell 8B 4.5/3.25 / NCS 4822 B05G				
	Corrosion class	C3 medium according to ISO/EN 12944-2				
<b>Bearings</b>	D-end	6309-2Z/C3	6310-2Z/C3	6312-2Z/C3	6313-2Z/C3	6315-2Z/C3
	N-end	6209-2Z/C3	6210-2Z/C3	6210-2Z/C3	6212-2Z/C3	6213-2Z/C3
<b>Axially-locked bearings</b>	Inner bearing cover	As standard, locked at D-end				
<b>Bearing seal</b>		Axial seal as standard, radial seal on request				
<b>Lubrication</b>		Permanently lubricated shielded bearings. Wide temperature grease.				
<b>Rating plate</b>	Material	Stainless steel, SS-EN 10088, 0.5 mm				
<b>Terminal box</b>	Material	Cast iron EN-GJL-200/GG 20/GRS 200				
	Surface treatment	Two-pack epoxy pain paint, $\geq 100\mu\text{m}$				
	Screws	Steel 8.8, zinc electroplated and chromated				
<b>Connections</b>	Cable entries	2xM40, 1xM16		2xM63, 1xM16		
	Terminals	6 terminals for connection with cable lugs (not included)				
<b>Fan</b>	Material	Polypropylene. Reinforced with 20% glass fibre.				
<b>Fan cover</b>	Material	Hot dip galvanized steel				
	Paint colour shade	Blue, Munsell 8B 4.5/3.25 / NCS 4822 B05G				
	Corrosion class	C3 medium according to ISO/EN 12944-2				
<b>Stator winding</b>	Material	Copper				
	Insulation	Insulation class F				
	Winding protection	3 PTC thermistors as standard, 150°C				
<b>Rotor winding</b>	Material	Pressure die-cast aluminum				
<b>Balancing method</b>		Half key balancing as standard				
<b>Key ways</b>		Closed key way				
<b>Heating elements</b>	On request	25 W	50 W	50 W	50 W	50 W
<b>Drain holes</b>		Standard, open on delivery				
<b>Enclosure</b>		IP 55, higher protection on request				
<b>Cooling method</b>		IC 411				









# ABB Motors' total product offer



ABB offers several comprehensive ranges of AC motors and generators. We manufacture synchronous motors for even the most demanding applications, and a full range of low and high voltage induction motors. Our in-depth knowledge of virtually every type of industrial processing ensures we always specify the best solution for your needs.

## Low voltage motors and generators

### Process performance motors for more demanding applications

- Cast iron motors
- Premium efficiency motors
- NEMA motors

### Industrial performance motors

- flexibility for most customer applications
- Aluminum motors
- Steel motors
- Cast iron motors

### General performance motors

- out-of-the-box simplicity for high volume customers
- Aluminum motors
- Cast iron motors

### Motors for hazardous areas

- Flameproof motors
- Increased safety motors
- Non-sparking motors
- Dust ignition proof motors

### Marine motors

- Aluminum motors
- Steel motors
- Cast iron motors
- Open drip proof motors

## Motors for additional application

- Open drip proof motors
- Brake motors
- Single phase motors
- High ambient motors
- Permanent magnet motors
- High speed motors
- Wind turbine generators
- Smoke venting motors
- Water cooled motors
- Motors for roller table drives
- Servomotors

## High voltage and synchronous motors and generators

- High voltage cast iron motors
- Induction modular motors
- Slip ring motors
- Motors for hazardous areas
- Synchronous motors and generators
- DC motors and generators
- Wind turbine generators
- Traction motors

# Visit our web site

[www.abb.com/motors&generators](http://www.abb.com/motors&generators)

## Motors & Generators

### > Motors

#### >> Low Voltage Motors

Process performance motors

#### >>> Industrial performance motors

>>>> Aluminum motors

>>>> Steel motors

>>>> Cast iron motors

General performance motors

Motors for hazardous areas

Marine motors

Motors for additional applications

The screenshot shows the ABB website's main navigation and product overview. The ABB logo is at the top left with the tagline "Power and productivity for a better world™". The top right contains links for "Sitemap", "Login", and "A A A". The main navigation bar includes "Home", "About ABB", "Products & services", "News center", "Careers", and "Investor relations". Below this is a secondary navigation bar with "Offerings A-Z", "ABB Product Guide", "Industries and utilities", "Service Guide", and "Contact Directory". The breadcrumb trail reads "Product Guide > Motors and Generators > Motors".

The main content area is titled "Motors for All Applications" and features a large image of a motor. Below the image is a grid of product categories: "Low Voltage Motors", "High Voltage Induction Motors", "Motors for Hazardous Areas", "Synchronous Motors", "DC Motors", "Motor Services", "Servomotors and servodrives", and "Traction Motors".

On the right side, there is a search bar, a "Products & Services only" checkbox, and options to "Rate this page" and "E-mail this page". Below these are "Your preferences" for "Other countries" (set to English) and "Language" (set to English). Further down are sections for "ABB contact for Other countries" with a "FeedbackMaster" link, "Documents" with a "Document Library" link, and "Links" with a "Channel partner and Service network" link.

This screenshot shows the "Low Voltage Motors" page. The breadcrumb trail is "Product Guide > Motors and Generators > Motors > Low Voltage Motors". The main heading is "Low voltage motors" with a sub-heading "ABB launches low voltage AC motors with improved energy efficiency and lifecycle value. At the same time, the company has rearranged its standard motor portfolio into three ranges." A large image of a motor is on the right.

The text below the heading states: "The International Electrotechnical Commission (IEC) standards relating to energy efficient motors is expected to bring greater consistency to motor testing worldwide. Please read more about IEC 60034-2-1 (efficiency measurement methods) and IEC 60034-30 (efficiency classes)."

The page is divided into three sections: "Standard motors" and "Other applications".

- Standard motors:**
  - Process performance motors:** Reach for the ultimate - best in class.
  - General performance motors:** Out-of-the-box simplicity for high volume customers.
  - Industrial performance motors:** A perfect sense of balance - providing optimal flexibility.
- Other applications:**
  - Motors for hazardous areas:** All protection types, certified according to all.
  - Marine motors:** All major classification societies certified.

The right sidebar is identical to the homepage screenshot, featuring search, preferences, and contact information.

This screenshot shows the "Industrial performance motors" page. The breadcrumb trail is "Product Guide > Motors and Generators > Motors > Low Voltage Motors > Industrial performance motors". The main heading is "Industrial performance motors" with a sub-heading "ABB's Industrial performance motors offer the flexibility needed by most of our OEM customers. All variant codes normally needed by OEM customers are available. Motors fulfill IE2 efficiency class requirements." A large image of a motor is on the right.

The page lists three motor types with their specifications:

- Aluminum motors:** Motor type M3AA, IEC sizes 63 to 280, 0.12 to 90 kW.
- Cast iron motors:** Motor type M3BA, IEC sizes 71 to 250, 0.25 to 55 kW.
- Steel motors:** Motor type M2CA, IEC sizes 280 to 400, 75 to 630 kW.

The right sidebar is identical to the previous screenshots, featuring search, preferences, and contact information.

# Contact us

[www.abb.com/motors&generators](http://www.abb.com/motors&generators)

© Copyright 2010 ABB.  
All rights reserved.  
Specifications subject to change  
without notice.

9AKK104559 EN 02-2010 Waasa Graphics Oy