

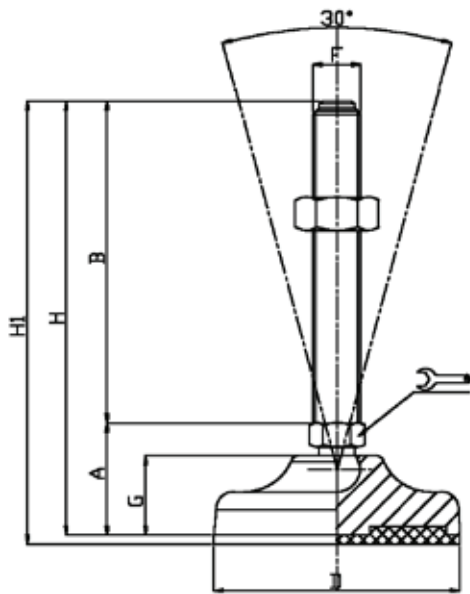

LINEA ACCIAIO **STEEL LINE**



- PAG. **156** **SNODATO**
ARTICULATED
- PAG. **163** **MEDIA PORTATA**
MEDIUM LOAD
- PAG. **175** **VULCANIZZATO**
VULCANIZED
- PAG. **185** **CARICHI PESANTI**
HEAVY DUTY



CODICE - CODE		descrizione description	DIMENSIONI PRINCIPALI - MAIN DIMENSIONS								CARICO STATICO STATIC LOAD NEWTON
standard standard	antiscivolo antislip		A	B	D		F	G	H	H1	
10678	10679	M10X25	28	25	Ø 50	14	M10	16	53	56	15000
10680	10681	M10X50	28	50	Ø 50	14	M10	16	78	81	15000
10682	10683	M10X75	28	75	Ø 50	14	M10	16	103	106	15000
10684	10685	M10X100	28	100	Ø 50	14	M10	16	128	131	15000
10686	10687	M10X125	28	125	Ø 50	14	M10	16	153	156	15000
10688	10689	M12X25	28	25	Ø 50	14	M12	16	53	56	15000
10690	10691	M12X50	28	50	Ø 50	14	M12	16	78	81	15000
10692	10693	M12X75	28	75	Ø 50	14	M12	16	103	106	15000
10694	10695	M12X100	28	100	Ø 50	14	M12	16	128	131	15000
10696	10697	M12X125	28	125	Ø 50	14	M12	16	153	156	15000
10698	10699	M14X25	28	25	Ø 50	14	M14	16	53	56	15000
10700	10701	M14X50	28	50	Ø 50	14	M14	16	78	81	15000
10702	10703	M14X75	28	75	Ø 50	14	M14	16	103	106	15000
10704	10705	M14X100	28	100	Ø 50	14	M14	16	128	131	15000
10706	10707	M14X125	28	125	Ø 50	14	M14	16	153	156	15000

- Materiale base: acciaio verniciato giallo. A richiesta disponibile con gomma antiscivolo NBR 70 shore (codice standard = senza gomma)
- Materiale stelo: acciaio zincato FE Su richiesta l'elemento di livellamento viene fornito con dado in acciaio.
- I valori dei carichi sopra riportati sono calcolati in condizioni statiche alla metà della lunghezza dello stelo filettato. Qualora s'intendesse utilizzare i supporti in presenza di vibrazioni o carichi in movimento, tali valori dovranno essere adeguatamente ridotti. Per ulteriori chiarimenti consultare il nostro ufficio tecnico. Ogni nostra responsabilità decade in caso di manomissioni o modifiche dei componenti.
- *Yellow painted steel base. On request non-skid plate in NBR rubber 70 shore is available (Standard CODE = without rubber)*
- *Articulated galvanized steel screw. The leveling element could be supplied, on request, with steel nut.*
- *Load values above mentioned have to be considered referring to static conditions calculated at the half of the screw length. In conditions of vibrations or in presence of dynamic loads these values should be reduced. For further information consult our technical office. We cannot accept responsibility for mounts that have been tampered or modified*

BASE VERNICIATA Ø 65 CON STELO SNODATO ZINCATO 30°
YELLOW PAINTED STEEL BASE Ø 65 WITH ARTICULATED STEEL SCREW 30°

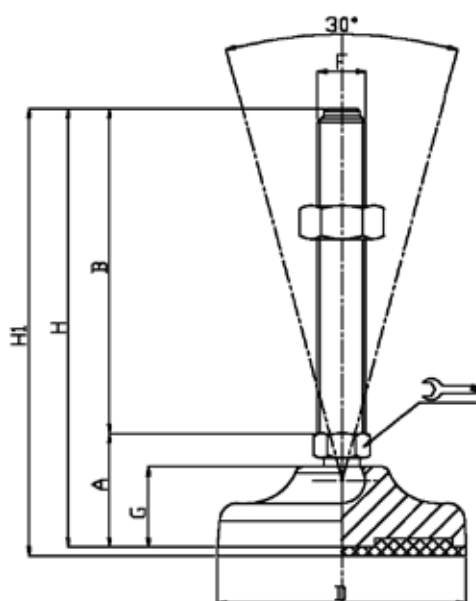

CODICE - CODE		descrizione description	DIMENSIONI PRINCIPALI - MAIN DIMENSIONS								CARICO STATICO STATIC LOAD NEWTON
standard standard	antiscivolo antislip		A	B	D		F	G	H	H1	
10708	10709	M14X50	30	50	Ø 65	14	M14	17	80	83	20000
10710	10711	M14X75	30	75	Ø 65	14	M14	17	105	108	20000
10712	10713	M14X100	30	100	Ø 65	14	M14	17	130	133	20000
10714	10715	M14X125	30	125	Ø 65	14	M14	17	155	158	20000
10716	10717	M14X150	30	150	Ø 65	14	M14	17	180	183	20000
10720	10721	M16X50	30	50	Ø 65	16	M16	17	80	83	20000
10722	10723	M16X75	30	75	Ø 65	16	M16	17	105	108	20000
10724	10725	M16X100	30	100	Ø 65	16	M16	17	130	133	20000
10726	10727	M16X125	30	125	Ø 65	16	M16	17	155	158	20000
10728	10729	M16X150	30	150	Ø 65	16	M16	17	180	183	20000
10730	10731	M16X175	30	175	Ø 65	16	M16	17	205	208	20000

ACCIAIO

- Materiale base: acciaio verniciato giallo. A richiesta disponibile con gomma antiscivolo NBR 70 shore (codice standard = senza gomma)
- Materiale stelo: acciaio zincato FE Su richiesta l'elemento di livellamento viene fornito con dado in acciaio.
- I valori dei carichi sopra riportati sono calcolati in condizioni statiche alla metà della lunghezza dello stelo filettato. Qualora s'intendesse utilizzare i supporti in presenza di vibrazioni o carichi in movimento, tali valori dovranno essere adeguatamente ridotti. Per ulteriori chiarimenti consultare il nostro ufficio tecnico. Ogni nostra responsabilità decade in caso di manomissioni o modifiche dei componenti.
- *Yellow painted steel base. On request non-skid plate in NBR rubber 70 shore is available (Standard CODE = without rubber)*
- *Articulated galvanized steel screw. The leveling element could be supplied, on request, with steel nut.*
- *Load values above mentioned have to be considered referring to static conditions calculated at the half of the screw length. In conditions of vibrations or in presence of dynamic loads these values should be reduced. For further information consult our technical office. We cannot accept responsibility for mounts that have been tampered or modified*

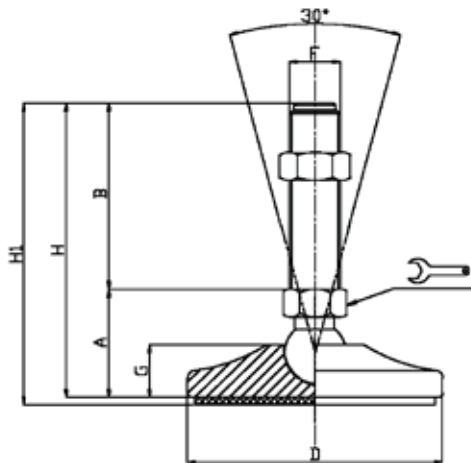

CODICE - CODE		descrizione description	DIMENSIONI PRINCIPALI - MAIN DIMENSIONS								CARICO STATICO STATIC LOAD NEWTON
standard standard	antiscivolo antislip		A	B	D		F	G	H	H1	
10734	10735	M16X50	33	50	Ø 80	16	M16	19,5	83	86	30000
10736	10737	M16X75	33	75	Ø 80	16	M16	19,5	108	111	30000
10738	10739	M16X100	33	100	Ø 80	16	M16	19,5	133	136	30000
10740	10741	M16X125	33	125	Ø 80	16	M16	19,5	158	161	30000
10742	10743	M16X150	33	150	Ø 80	16	M16	19,5	183	186	30000
10744	10745	M16X175	33	175	Ø 80	16	M16	19,5	208	211	30000
10746	10747	M16X200	33	200	Ø 80	16	M16	19,5	233	236	30000

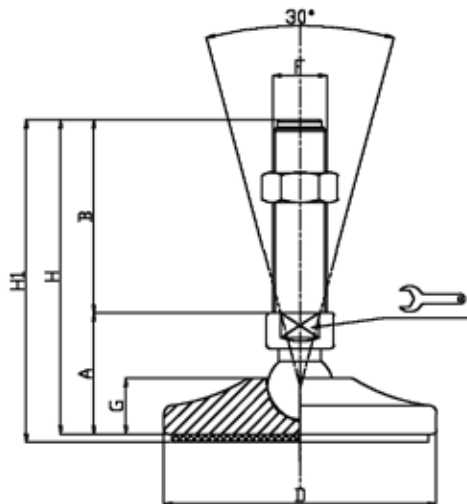



CODICE - CODE		descrizione description	DIMENSIONI PRINCIPALI - MAIN DIMENSIONS								CARICO STATICO STATIC LOAD NEWTON
standard standard	antiscivolo antislip		A	B	D		F	G	H	H1	
10748	10749	M20X75	36	75	Ø 80	17	M20	19,5	111	114	30000
10750	10751	M20X100	36	100	Ø 80	17	M20	19,5	136	139	30000
10752	10753	M20X125	36	125	Ø 80	17	M20	19,5	161	164	30000
10754	10755	M20X150	36	150	Ø 80	17	M20	19,5	186	189	30000
10756	10757	M20X175	36	175	Ø 80	17	M20	19,5	211	214	30000
10758	10759	M20X200	36	200	Ø 80	17	M20	19,5	236	239	30000
10760	10761	M20X225	36	225	Ø 80	17	M20	19,5	261	264	30000

- Materiale base: acciaio verniciato giallo. A richiesta disponibile con gomma antiscivolo NBR 70 shore (codice standard = senza gomma)
- Materiale stelo: acciaio zincato FE Su richiesta l'elemento di livellamento viene fornito con dado in acciaio.
- *Yellow painted steel base. On request non-skid plate in NBR rubber 70 shore is available (Standard CODE = without rubber)*
- *Articulated galvanized steel screw. The leveling element could be supplied, on request, with steel nut.*

BASE VERNICIATA Ø 100 CON STELO SNODATO ZINCATO 30°

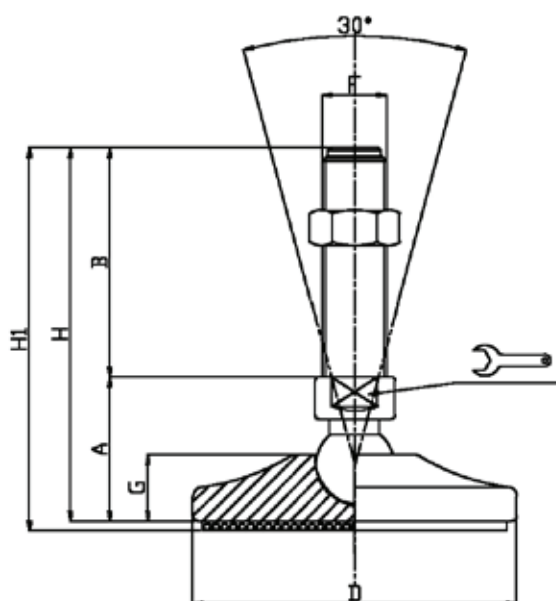
YELLOW PAINTED STEEL BASE Ø 100 WITH ARTICULATED STEEL SCREW 30°





CODICE - CODE		descrizione description	DIMENSIONI PRINCIPALI - MAIN DIMENSIONS								CARICO STATICO STATIC LOAD NEWTON
standard standard	antiscivolo antislip		A	B	D		F	G	H	H1	
10762	10763	M16X50	43	50	Ø 100	20	M16	20	93	96	35000
10764	10765	M16X75	43	75	Ø 100	20	M16	20	118	121	35000
10766	10767	M16X100	43	100	Ø 100	20	M16	20	143	146	35000
10768	10769	M16X125	43	125	Ø 100	20	M16	20	168	171	35000
10770	10771	M16X150	43	150	Ø 100	20	M16	20	193	196	35000
10772	10773	M16X175	43	175	Ø 100	20	M16	20	218	221	35000
10774	10775	M16X200	43	200	Ø 100	20	M16	20	243	246	35000
10780	10781	M20X75	43	75	Ø 100	20	M20	20	118	121	45000
10782	10783	M20X100	43	100	Ø 100	20	M20	20	143	146	45000
10784	10785	M20X125	43	125	Ø 100	20	M20	20	168	171	45000
10786	10787	M20X150	43	150	Ø 100	20	M20	20	193	196	45000
10788	10789	M20X175	43	175	Ø 100	20	M20	20	218	221	45000
10790	10791	M20X200	43	200	Ø 100	20	M20	20	243	246	45000
10792	10793	M20X225	43	225	Ø 100	20	M20	20	268	271	45000
10794	10795	M20X250	43	250	Ø 100	20	M20	20	293	296	45000
10798	10799	M24X75	44	75	Ø 100	20	M24	20	119	122	55000
10800	10801	M24X100	44	100	Ø 100	20	M24	20	144	147	55000
10802	10803	M24X125	44	125	Ø 100	20	M24	20	169	172	55000
* 10804	10805	M24X150	44	150	Ø 100	20	M24	20	199	202	55000
10806	10807	M24X175	44	175	Ø 100	20	M24	20	219	222	55000
* 10808	10809	M24X200	44	200	Ø 100	20	M24	20	244	247	55000
10810	10811	M24X225	44	225	Ø 100	20	M24	20	269	272	55000
10812	10813	M24X250	44	250	Ø 100	20	M24	20	294	297	55000

* Disponibile con Filettatura a passo fine. Aggiungere "/P2" al codice
Available with Thin pitch thread. Please, add "/P2" to the code

- Materiale base: acciaio verniciato giallo. A richiesta disponibile con gomma antiscivolo NBR 70 shore (codice standard = senza gomma)
- Materiale stelo: acciaio zincato FE Su richiesta l'elemento di livellamento viene fornito con dado in acciaio.
- I valori dei carichi sopra riportati sono calcolati in condizioni statiche alla metà della lunghezza dello stelo filettato. Qualora s'intendesse utilizzare i supporti in presenza di vibrazioni o carichi in movimento, tali valori dovranno essere adeguatamente ridotti. Per ulteriori chiarimenti consultare il nostro ufficio tecnico. Ogni nostra responsabilità decade in caso di manomissioni o modifiche dei componenti.
- Yellow painted steel base. On request non-skid plate in NBR rubber 70 shore is available (Standard CODE = without rubber)
- Articulated galvanized steel screw. The leveling element could be supplied, on request, with steel nut.
- Load values above mentioned have to be considered referring to static conditions calculated at the half of the screw length. In conditions of vibrations or in presence of dynamic loads these values should be reduced. For further information consult our technical office. We cannot accept responsibility for mounts that have been tampered or modified

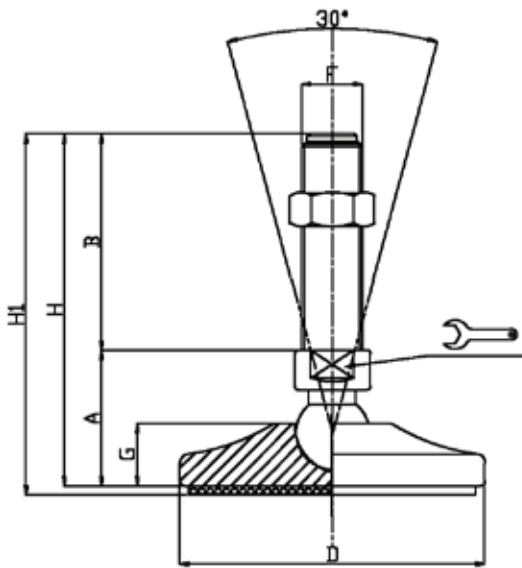
ACCIAIO



CODICE - CODE		descrizione description	DIMENSIONI PRINCIPALI - MAIN DIMENSIONS								CARICO STATICO STATIC LOAD NEWTON
standard standard	antiscivolo antislip		A	B	D		F	G	H	H1	
10814	10815	M16X50	46	50	Ø 120	20	M16	23	96	99	35000
10816	10817	M16X75	46	75	Ø 120	20	M16	23	121	124	35000
10818	10819	M16X100	46	100	Ø 120	20	M16	23	146	149	35000
10820	10821	M16X125	46	125	Ø 120	20	M16	23	171	174	35000
10822	10823	M16X150	46	150	Ø 120	20	M16	23	196	199	35000
10824	10825	M16X175	46	175	Ø 120	20	M16	23	221	224	35000
10826	10827	M16X200	46	200	Ø 120	20	M16	23	246	249	35000
10832	10833	M20X75	46	75	Ø 120	20	M20	23	121	124	45000
10834	10835	M20X100	46	100	Ø 120	20	M20	23	146	149	45000
10836	10837	M20X125	46	125	Ø 120	20	M20	23	171	174	45000
10838	10839	M20X150	46	150	Ø 120	20	M20	23	196	199	45000
10840	10841	M20X175	46	175	Ø 120	20	M20	23	221	224	45000
10842	10843	M20X200	46	200	Ø 120	20	M20	23	246	249	45000
10844	10845	M20X225	46	225	Ø 120	20	M20	23	271	274	45000
10846	10847	M20X250	46	250	Ø 120	20	M20	23	296	299	45000

- Materiale base: acciaio verniciato giallo. A richiesta disponibile con gomma antiscivolo NBR 70 shore (codice standard = senza gomma)
- Materiale stelo: acciaio zincato FE Su richiesta l'elemento di livellamento viene fornito con dado in acciaio.
- I valori dei carichi sopra riportati sono calcolati in condizioni statiche alla metà della lunghezza dello stelo filettato. Qualora s'intendesse utilizzare i supporti in presenza di vibrazioni o carichi in movimento, tali valori dovranno essere adeguatamente ridotti. Per ulteriori chiarimenti consultare il nostro ufficio tecnico. Ogni nostra responsabilità decade in caso di manomissioni o modifiche dei componenti.
- *Yellow painted steel base. On request non-skid plate in NBR rubber 70 shore is available (Standard CODE = without rubber)*
- *Articulated galvanized steel screw. The leveling element could be supplied, on request, with steel nut.*
- *Load values above mentioned have to be considered referring to static conditions calculated at the half of the screw length. In conditions of vibrations or in presence of dynamic loads these values should be reduced. For further information consult our technical office. We cannot accept responsibility for mounts that have been tampered or modified*

BASE VERNICIATA Ø 120 CON STELO SNODATO ZINCATO 30°
YELLOW PAINTED STEEL BASE Ø 120 WITH ARTICULATED STEEL SCREW 30°

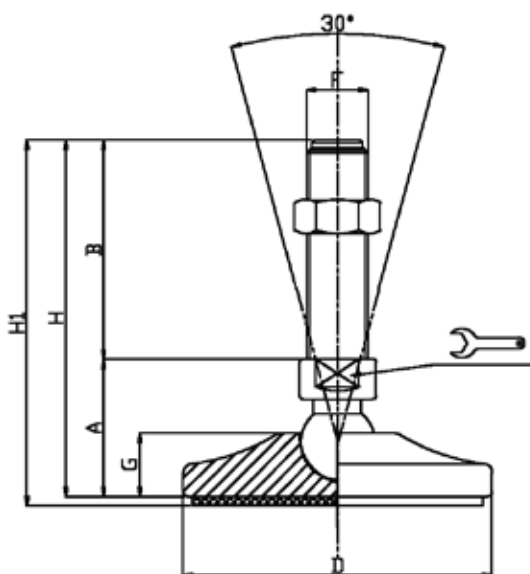

CODICE - CODE		descrizione description	DIMENSIONI PRINCIPALI - MAIN DIMENSIONS								CARICO STATICO STATIC LOAD NEWTON	
standard standard	antiscivolo antislip		A	B	D		F	G	H	H1		
10850	10851	M24X75	47	75	Ø 120	20	M24	23	122	125	55000	
10852	10853	M24X100	47	100	Ø 120	20	M24	23	147	150	55000	
10854	10855	M24X125	47	125	Ø 120	20	M24	23	172	175	55000	
*	10856	10857	M24X150	47	150	Ø 120	20	M24	23	197	200	55000
	10858	10859	M24X175	47	175	Ø 120	20	M24	23	222	225	55000
*	10860	10861	M24X200	47	200	Ø 120	20	M24	23	247	250	55000
	10862	10863	M24X225	47	225	Ø 120	20	M24	23	272	275	55000
	10864	10865	M24X250	47	250	Ø 120	20	M24	23	297	300	55000
	10866	10867	M30X100	47	100	Ø 120	26	M30	23	147	150	65000
	10868	10869	M30X125	47	125	Ø 120	26	M30	23	172	175	65000
*	10870	10871	M30X150	47	150	Ø 120	26	M30	23	197	200	65000
	10872	10873	M30X175	47	175	Ø 120	26	M30	23	222	225	65000
*	10874	10875	M30X200	47	200	Ø 120	26	M30	23	247	250	65000
	10876	10877	M30X225	47	225	Ø 120	26	M30	23	272	275	65000
	10878	10879	M30X250	47	250	Ø 120	26	M30	23	297	300	65000

* Disponibile con Filettatura a passo fine. Aggiungere "/P2" al codice
 Available with Thin pitch thread. Please, add "/P2" to the code

- Materiale base: acciaio verniciato giallo. A richiesta disponibile con gomma antiscivolo NBR 70 shore (codice standard = senza gomma)
- Materiale stelo: acciaio zincato FE Su richiesta l'elemento di livellamento viene fornito con dado in acciaio.
- I valori dei carichi sopra riportati sono calcolati in condizioni statiche alla metà della lunghezza dello stelo filettato. Qualora s'intendesse utilizzare i supporti in presenza di vibrazioni o carichi in movimento, tali valori dovranno essere adeguatamente ridotti. Per ulteriori chiarimenti consultare il nostro ufficio tecnico. Ogni nostra responsabilità decade in caso di manomissioni o modifiche dei componenti.
- Yellow painted steel base. On request non-skid plate in NBR rubber 70 shore is available (Standard CODE = without rubber)
- Articulated galvanized steel screw. The leveling element could be supplied, on request, with steel nut.
- Load values above mentioned have to be considered referring to static conditions calculated at the half of the screw length. In conditions of vibrations or in presence of dynamic loads these values should be reduced. For further information consult our technical office. We cannot accept responsibility for mounts that have been tampered or modified

ACCIAIO