

Martin
Levelling Components
Made in Italy

LINEA MINI
MINI LINE

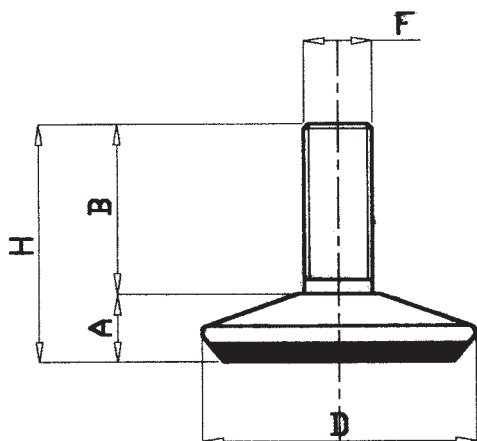



CODICE - CODE	descrizione - description	DIMENSIONI PRINCIPALI - MAIN DIMENSIONS					CARICO STATICO STATIC LOAD NEWTON
		B	D	F	A	H	
30000	M6x13	13	Ø 20	M6	7	20	1000
30010	M8x20	20	Ø 25	M8	10	30	1500
30020	M10x20	20	Ø 25	M10	10	30	1500
30030	M8x20	20	Ø 30	M8	11,5	31,5	2000
30040	M10x20	20	Ø 30	M10	11,5	31,5	2000
30050	M8x25	25	Ø 40	M8	13,5	38,5	2800
30060	M10x25	25	Ø 40	M10	13,5	38,5	2800
30070	M10x30	30	Ø 50	M10	15,5	45,5	3800
30080	M12x35	30	Ø 50	M12	15,5	50,5	3800

• Base in poliammide con stelo in ferro zincato e cuffia cromata

• I valori dei carichi sopra riportati sono calcolati in condizioni statiche. Qualora s'intendesse utilizzare i supporti in presenza di vibrazioni o carichi in movimento, tali valori dovranno essere adeguatamente ridotti. Per ulteriori chiarimenti consultare il nostro ufficio tecnico. Ogni nostra responsabilità decade in caso di manomissioni o modifiche dei componenti.

• Polyamide base with chromate case, galvanized steel screw

• Load values above mentioned have to be considered referring to static conditions calculated at the half of the screw length. In conditions of vibrations or in presence of dynamic loads these values should be reduced. For further information consult our technical office. We cannot accept responsibility for mounts that have been tampered or modified.

PIEDE FISSO IN POLIAMMIDE Ø 30/60
POLYAMIDE FIXED FOOT Ø 30/60

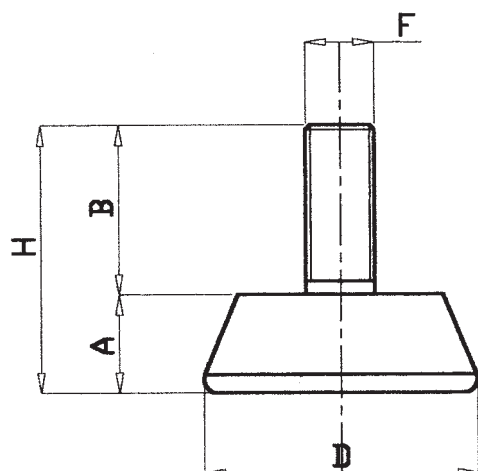

CODICE - CODE	descrizione - description	DIMENSIONI PRINCIPALI - MAIN DIMENSIONS					CARICO STATICO STATIC LOAD NEWTON
		B	D	F	A	H	
30100	M8x20	20	Ø 30	M8	11,5	31,5	2000
30110	M10x20	20	Ø 30	M10	11,5	31,5	2000
30120	M8x25	25	Ø 40	M8	14,5	39,5	2500
30130	M10x25	25	Ø 40	M10	14,5	39,5	2500
30140	M10x35	35	Ø 50	M10	17	52	3500
30150	M12x35	35	Ø 50	M12	17	52	3500
30160	M12x35	35	Ø 60	M12	17	52	4000

• Base in poliammide, stelo in ferro zincato

• I valori dei carichi sopra riportati sono calcolati in condizioni statiche. Qualora s'intendesse utilizzare i supporti in presenza di vibrazioni o carichi in movimento, tali valori dovranno essere adeguatamente ridotti. Per ulteriori chiarimenti consultare il nostro ufficio tecnico. Ogni nostra responsabilità decade in caso di manomissioni o modifiche dei componenti.

• Polyamide base, galvanized steel screw

• Load values above mentioned have to be considered referring to static conditions calculated at the half of the screw length. In conditions of vibrations or in presence of dynamic loads these values should be reduced. For further information consult our technical office. We cannot accept responsibility for mounts that have been tampered or modified.

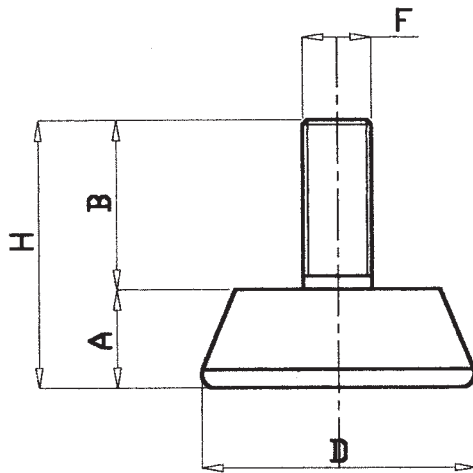

CODICE - CODE	descrizione - description	DIMENSIONI PRINCIPALI - MAIN DIMENSIONS					CARICO STATICO STATIC LOAD NEWTON
		B	D	F	A	H	
7040-8X25F	Stelo zincato M8x25	25	Ø 40	M8	16	41	1800
7040-10X25F	Stelo zincato M10x25	25	Ø 40	M10	16	41	2250
7040-12X25F	Stelo zincato M12x25	25	Ø 40	M12	16	41	3150
7040-8X25I	Stelo inox M8x25	25	Ø 40	M8	16	41	1800
7040-10X25I	Stelo inox M10x25	25	Ø 40	M10	16	41	2250
7040-12X25I	Stelo inox M12x25	25	Ø 40	M12	16	41	3150

- Base in gomma NBR 70 shore; stelo acciaio zincato/inox (AISI 304)
- I valori dei carichi sopra riportati sono calcolati in condizioni statiche. Qualora s'intendesse utilizzare i supporti in presenza di vibrazioni o carichi in movimento, tali valori dovranno essere adeguatamente ridotti. Per ulteriori chiarimenti consultare il nostro ufficio tecnico. Ogni nostra responsabilità decade in caso di manomissioni o modifiche dei componenti.
- Rubber base (NBR 70 shore). Steel/stainless steel (1.4301) screw.
- Load values above mentioned have to be considered referring to static conditions calculated at the half of the screw length. In conditions of vibrations or in presence of dynamic loads these values should be reduced. For further information consult our technical office. We cannot accept responsibility for mounts that have been tampered or modified.

PIEDE FISSO IN GOMMA ANTISCIVOLO Ø 30/35
RUBBER FIXED FOOT Ø 30/35

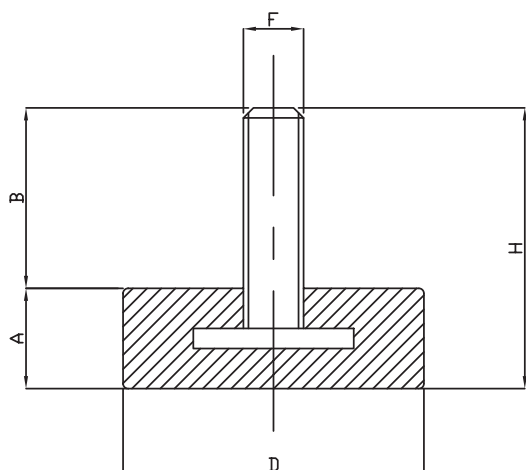

CODICE - CODE	descrizione - description	DIMENSIONI PRINCIPALI - MAIN DIMENSIONS					CARICO STATICO STATIC LOAD NEWTON
		A	D	F	B	H	
7030-6X18F	M6x18	10	Ø 30	M6	18	28	1000
7030-6X38F	M6x38	10	Ø 30	M6	38	48	1000
7030-8X18F	M8x18	10	Ø 30	M8	18	28	1200
7030-8X38F	M8x38	10	Ø 30	M8	38	48	1200
7030-10X28F	M10x28	10	Ø 30	M10	28	38	1400
7030-10X38F	M10x38	10	Ø 30	M10	38	48	1400
7030-12X28F	M12x28	10	Ø 30	M12	28	38	1500
7035-8X18F	M8x18	12	Ø 35	M8	18	30	1200
7035-8X38F	M8x38	12	Ø 35	M8	38	50	1200
7035-10X18F	M10x18	12	Ø 35	M10	18	30	1400
7035-10X38F	M10x38	12	Ø 35	M10	38	50	1400
7035-12X18F	M12x18	12	Ø 35	M12	18	30	1500
7035-12X38F	M12x38	12	Ø 35	M12	38	50	1500

• A richiesta disponibile anche con stelo in acciaio inox.
 Minimo 500 pz.

• Base in gomma NBR 70 shore; stelo acciaio zincato

• I valori dei carichi sopra riportati sono calcolati in condizioni statiche. Qualora s'intendesse utilizzare i supporti in presenza di vibrazioni o carichi in movimento, tali valori dovranno essere adeguatamente ridotti. Per ulteriori chiarimenti consultare il nostro ufficio tecnico. Ogni nostra responsabilità decade in caso di manomissioni o modifiche dei componenti.

• Rubber base (NBR 70 shore). Steel/stainless steel (1.4301) screw on request.

• Load values above mentioned have to be considered referring to static conditions calculated at the half of the screw length. In conditions of vibrations or in presence of dynamic loads these values should be reduced. For further information consult our technical office. We cannot accept responsibility for mounts that have been tampered or modified.

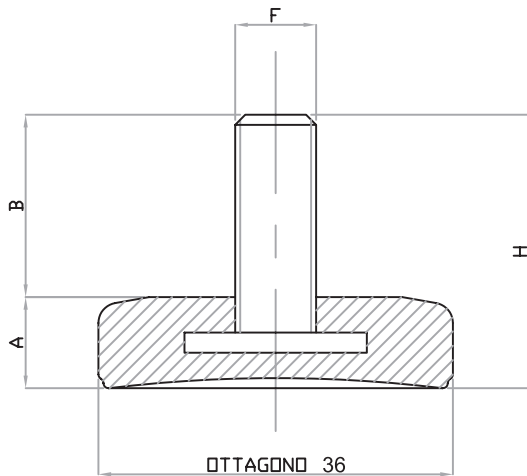

CODICE - CODE	descrizione - description	DIMENSIONI PRINCIPALI - MAIN DIMENSIONS					CARICO STATICO STATIC LOAD NEWTON
		B	D	F	A	H	
70350-8X18F	Stelo zincato M8x18	20	Ø 38	M8	9	29	1800
70350-8X38F	Stelo zincato M8x38	40	Ø 38	M8	9	49	2250
70350-10X18F	Stelo zincato M10x18	20	Ø 38	M10	9	29	3150
70350-10X38F	Stelo zincato M10x38	40	Ø 38	M10	9	49	3150

• A richiesta disponibile anche con stelo in acciaio inox.
Minimo 500 pz.

• Base in gomma NBR 70 shore; stelo acciaio zincato.

• I valori dei carichi sopra riportati sono calcolati in condizioni statiche. Qualora s'intendesse utilizzare i supporti in presenza di vibrazioni o carichi in movimento, tali valori dovranno essere adeguatamente ridotti. Per ulteriori chiarimenti consultare il nostro ufficio tecnico. Ogni nostra responsabilità decade in caso di manomissioni o modifiche dei componenti.

• Rubber base (NBR 70 shore). Steel/stainless steel (1.4301) screw on request.

• Load values above mentioned have to be considered referring to static conditions calculated at the half of the screw length. In conditions of vibrations or in presence of dynamic loads these values should be reduced. For further information consult our technical office. We cannot accept responsibility for mounts that have been tampered or modified.

PIEDE FISSO IN GOMMA ANTISCIVOLO Ø 50
RUBBER FIXED FOOT Ø 50

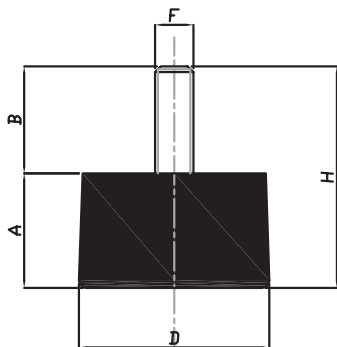

CODICE - CODE	descrizione - description	DIMENSIONI PRINCIPALI - MAIN DIMENSIONS					CARICO STATICO STATIC LOAD NEWTON
		B	D	F	A	H	
7050-10x28	Piede in gomma D50 M10	28	50	M10	30	58	3000

PIEDINO PER ELETTRODOMESTICI DA BANCO Ø48
RUBBER FOOT HOUSEHOLD ELECTRICAL APPLIANCES Ø48

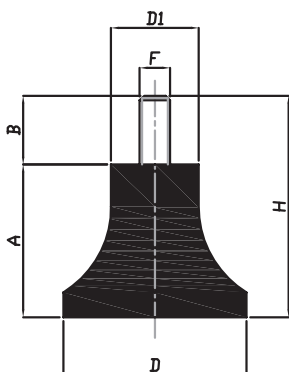

CODICE - CODE	descrizione description	DIMENSIONI PRINCIPALI - MAIN DIMENSIONS						CARICO STATICO STATIC LOAD NEWTON
		B	D1	D	F	A	H	
7048-8x18	Piede in gomma D48 M8	18	23	48	M8	40	58	3000

- Base in gomma NBR 70 shore; stelo acciaio zincato.
- Rubber base (NBR 70 shore). Steel.

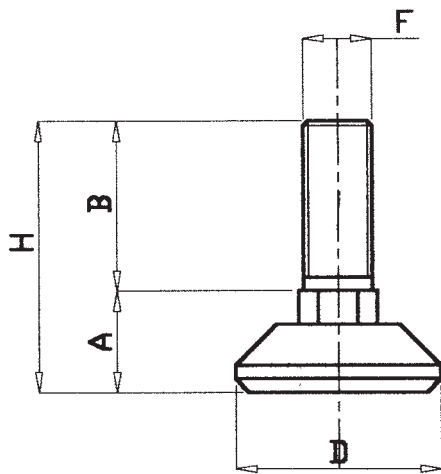

CODICE - CODE	descrizione - description	DIMENSIONI PRINCIPALI - MAIN DIMENSIONS					CARICO STATICO STATIC LOAD NEWTON
		B	D	F	A	H	
30200	M10x20	20	Ø 30	M10	15	35	800

• Base e stelo in poliammide

• I valori dei carichi sopra riportati sono calcolati in condizioni statiche. Qualora s'intendesse utilizzare i supporti in presenza di vibrazioni o carichi in movimento, tali valori dovranno essere adeguatamente ridotti. Per ulteriori chiarimenti consultare il nostro ufficio tecnico. Ogni nostra responsabilità decade in caso di manomissioni o modifiche dei componenti.

• *Polyamide base and screw/ Polyamid Grundplatte und Spindel*

• *Load values above mentioned have to be considered referring to static conditions calculated at the half of the screw length. In conditions of vibrations or in presence of dynamic loads these values should be reduced. For further information consult our technical office. We cannot accept responsibility for mounts that have been tampered or modified.*

PIEDI FISSO IN POLIAMMIDE CON ZIGRINATURA Ø 25/35 Ø 20/32
 POLYAMIDE FIXED FOOT Ø 25/35 Ø 20/32

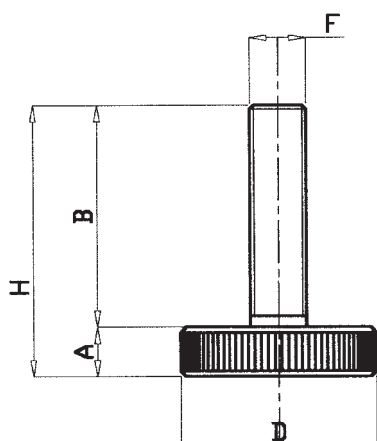

CODICE - CODE	descrizione - description	DIMENSIONI PRINCIPALI - MAIN DIMENSIONS					CARICO STATICO STATIC LOAD NEWTON
		B	D	F	A	H	
30400	M6x17	17	Ø 25	M6	7	24	1500
30410	M8x25	25	Ø 25	M8	7	32	1500
30420	M10x35	35	Ø 25	M10	7	42	1500
30430	M8x25	25	Ø 35	M8	9	34	2500
30440	M10x25	25	Ø 35	M10	9	34	2500
30450	M10x30	30	Ø 35	M10	9	39	2500
30460	M10x35	35	Ø 35	M10	9	44	2500
30470	M10x40	40	Ø 35	M10	9	49	2500

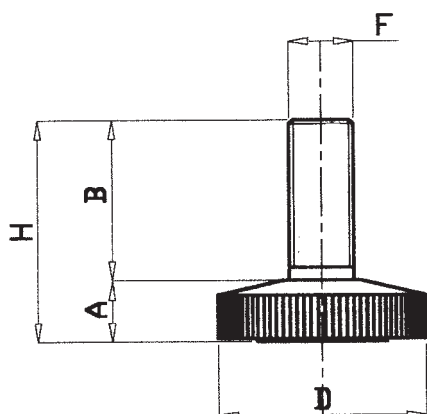

CODICE - CODE	descrizione - description	DIMENSIONI PRINCIPALI - MAIN DIMENSIONS					CARICO STATICO STATIC LOAD NEWTON
		B	D	F	A	H	
30300	M6x20	20	Ø 20	M6	6,5	26,5	1500
30310	M8x22	22	Ø 28	M8	8	30	2000
30320	M10x25	25	Ø 32	M10	9,5	34,5	2500

• Base in poliammide, stelo acciaio zincato

• Polyamide base, galvanized steel screw

MINI

PIEDE FISSO BASSO IN POLIAMMIDE Ø 40
POLYAMIDE FIXED FOOT Ø 40

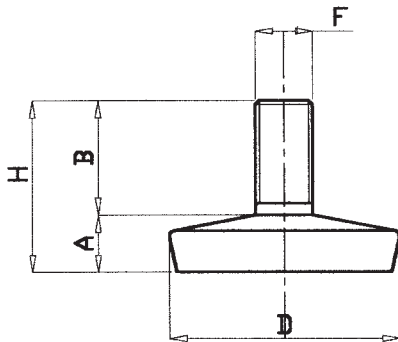

CODICE - CODE	descrizione - description	DIMENSIONI PRINCIPALI - MAIN DIMENSIONS					CARICO STATICO STATIC LOAD NEWTON
		B	D	F	A	H	
30500	M8x20	20	Ø 40	M8	10	30	3000
30510	M10x20	20	Ø 40	M10	10	30	3000

- Base in poliammide, stelo acciaio zincato
- Polyamide base, galvanized steel screw

PIEDE FISSO BASSO IN POLIAMMIDE CH 25
POLYAMIDE FIXED FOOT KEY 25

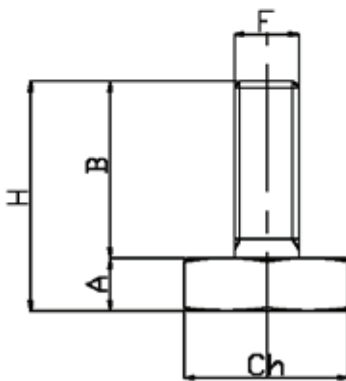

CODICE - CODE	descrizione - description	DIMENSIONI PRINCIPALI - MAIN DIMENSIONS					CARICO STATICO STATIC LOAD NEWTON
		B	CH	F	A	H	
30600	M8x25	25	Ø 25	M8	8	33	2500
30610	M8x35	35	Ø 25	M8	8	43	2500
30620	M10x25	25	Ø 25	M10	8	33	2500
30630	M10x35	35	Ø 25	M10	8	43	2500

- Base esagonale in poliammide con stelo in ferro zincato
- Hexagonal polyamide base, galvanized steel screw

PIEDI FISSO IN POLIAMMIDE CON SEDE ESAGONALE Ø 38
FIXED FOOT WITH HEXAGONAL SEAT Ø 38

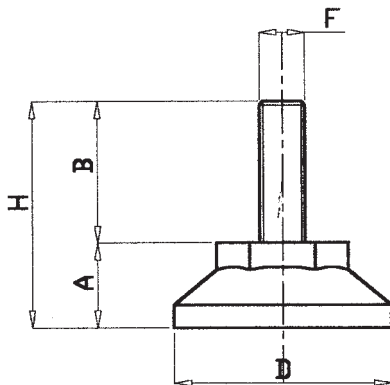

CODICE - CODE	descrizione - description	DIMENSIONI PRINCIPALI - MAIN DIMENSIONS					CARICO STATICO STATIC LOAD NEWTON
		B	D	F	A	H	
30700	M8x25	25	Ø 38	M8	15	40	2500

- Base in poliammide con sede esagonale, stelo acciaio zincato
- Polyamide base with Hexagonal seat, galvanized iron screw

BASE POLIAMMIDE COMPONENTIBILE Ø 40 PER M10
POLYAMIDE BASE Ø 40 FOR SCREW M10

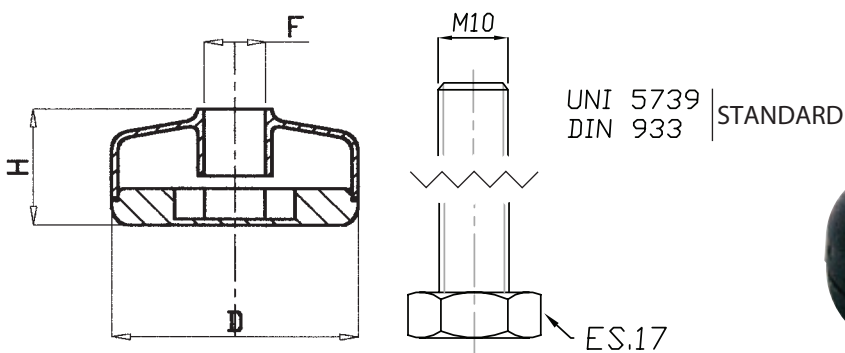

CODICE - CODE	descrizione - description	DIMENSIONI PRINCIPALI - MAIN DIMENSIONS			CARICO STATICO STATIC LOAD NEWTON
		D	F	H	
30800	Esagono Vite 17	Ø 40	M10	20	3000

- PA Base con alloggiamento per vite a testa esagonale 17 - DIN 933/UNI 5739
- Vite fornita su richiesta
- Lotto minimo per la base 1.000pz
- PA Base with socket for screw SW17 - DIN 933/UNI 5739
- Screw on request
- MOQ for PA base 1.000pcs

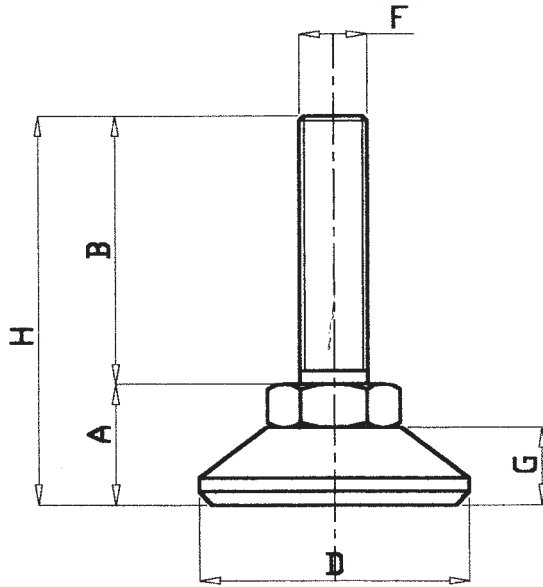

CODICE - CODE	descrizione - description	DIMENSIONI PRINCIPALI - MAIN DIMENSIONS						CARICO STATICO STATIC LOAD NEWTON
		B	D	F	A	H	G	
30900	M10x40	40	Ø 40	M10	18	58	11,5	3500
30910	M10x40 cromato	40	Ø 40	M10	18	58	11,5	3500
30920	M10x60	60	Ø 40	M10	18	78	11,5	3500
30930	M10x60 cromato	60	Ø 40	M10	18	78	11,5	3500
30940	M10x40	40	Ø 50	M10	20	60	13,5	4500
30950	M10x40 cromato	40	Ø 50	M10	20	60	13,5	4500
30960	M10x60	60	Ø 50	M10	20	80	13,5	4500
30970	M10x60 cromato	60	Ø 50	M10	20	80	13,5	4500

- Base in poliammide nero (disponibile anche con cuffia cromata) stelo leggermente snodato in ferro zincato
- I valori dei carichi sopra riportati sono calcolati in condizioni statiche. Qualora s'intendesse utilizzare i supporti in presenza di vibrazioni o carichi in movimento, tali valori dovranno essere adeguatamente ridotti. Per ulteriori chiarimenti consultare il nostro ufficio tecnico. Ogni nostra responsabilità decade in caso di manomissioni o modifiche dei componenti.
- Black polyamide base (chromate case available), slightly articulated galvanized steel screw
- Load values above mentioned have to be considered referring to static conditions calculated at the half of the screw length. In conditions of vibrations or in presence of dynamic loads these values should be reduced. For further information consult our technical office. We cannot accept responsibility for mounts that have been tampered or modified.

PIEDE POLIAMMIDE SNODATO Ø 26/38
POLYAMIDE ARTICULATED FOOT Ø 26/38

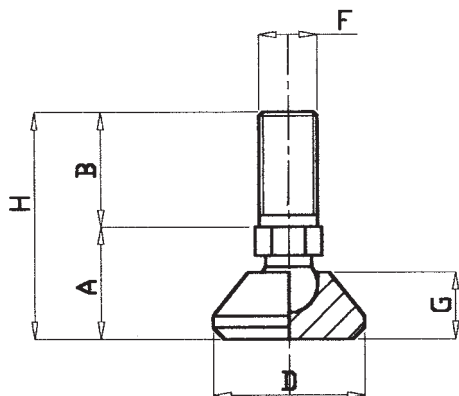

CODICE - CODE	descrizione - description	DIMENSIONI PRINCIPALI - MAIN DIMENSIONS						CARICO STATICO STATIC LOAD NEWTON
		B	D	F	A	H	G	
31000	M10x10	10	Ø 26	M10	16,5	26,5	11,5	1500
31010	M10x20	20	Ø 26	M10	16,5	36,5	11,5	1500
31020	M10x30	30	Ø 26	M10	16,5	46,5	11,5	1500

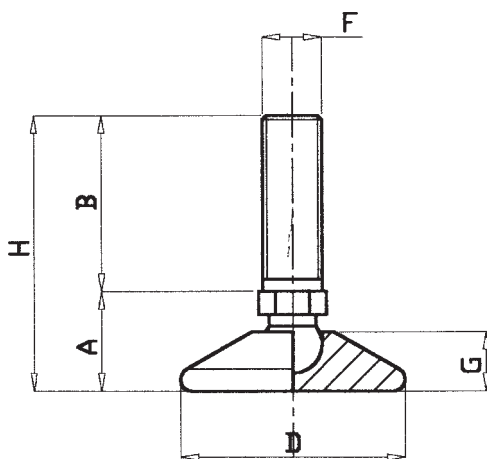

CODICE - CODE	descrizione - description	DIMENSIONI PRINCIPALI - MAIN DIMENSIONS						CARICO STATICO STATIC LOAD NEWTON
		B	D	F	A	H	G	
31100	M8x30	30	Ø 38	M8	14	44	10	3000

- Base in poliammide nero, stelo snodato in ferro zincato
- Black polyamide base, articulated galvanized steel screw

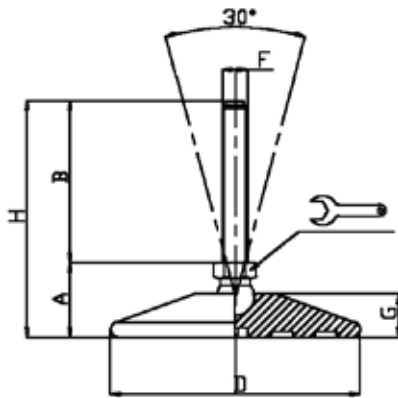

CODICE - CODE	descrizione description	DIMENSIONI PRINCIPALI - MAIN DIMENSIONS							CARICO STATICO STATIC LOAD NEWTON
		B	D	F	A	H	G	CH	
31150/Z	M10x50	50	80	M10	24	74	15	10	3000
31150/I	M10x50	50	80	M10	24	74	15	10	3000
31152/Z	M10x100	100	80	M10	24	124	15	10	3000
31152/I	M10x100	100	80	M10	24	124	15	10	3000
31154/Z	M12x50	50	80	M12	24	74	15	12	3000
31154/I	M12x50	50	80	M12	24	74	15	12	3000
31156/Z	M12x100	100	80	M12	24	124	15	12	3000
31156/I	M12x100	100	80	M12	24	124	15	12	3000

- Base in poliammide con sede cacciavite per avvitarmento automatico, stelo snodato zincato
- Polyamide base with screwdriver seat for automatic screwing. Galvanized steel screw

ASSIEME PLASTICA PER TUBO Ø 50 SP. 1,5
POLYAMIDE COMPONENT FOR TUBE Ø 50 TH. 1,5

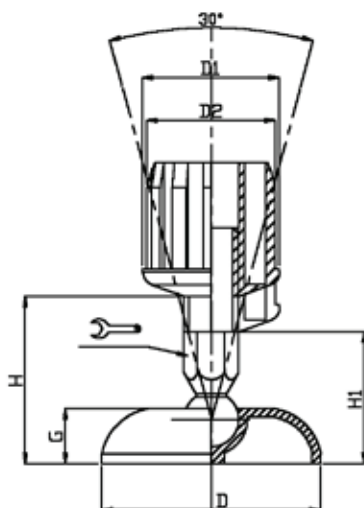

CODICE - CODE	DIMENSIONI PRINCIPALI - MAIN DIMENSIONS							CARICO STATICO STATIC LOAD NEWTON
	D	D1	D2	G	H	H1	CH	
31400	80	50	47	20	65	48	17	1000

- Base, stelo e tappo in poliammide
- Polyamide base, screw and plug

PIEDE IN ACCIAIO ZINCATO Ø 46
GALVANIZED FOOT Ø 46

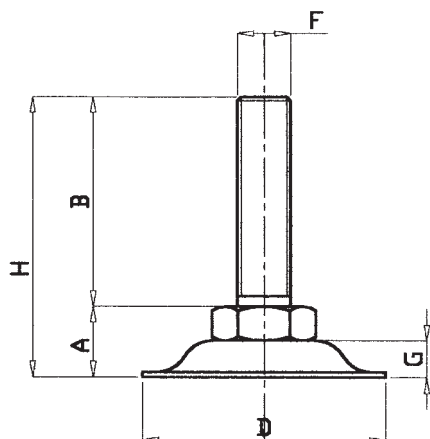

CODICE - CODE	descrizione - description	DIMENSIONI PRINCIPALI - MAIN DIMENSIONS						CARICO STATICO STATIC LOAD NEWTON
		B	D	F	A	H	G	
31200	M10x40	40	Ø 46	M10	13,5	53,5	7	5500
31210	M10x60	60	Ø 46	M10	13,5	73,5	7	5500

- Base e stelo in acciaio zincato
- Galvanized iron base, articulated galvanized steel screw

PIEDE IN ACCIAIO ZINCATO Ø 50
GALVANIZED FOOT Ø 50

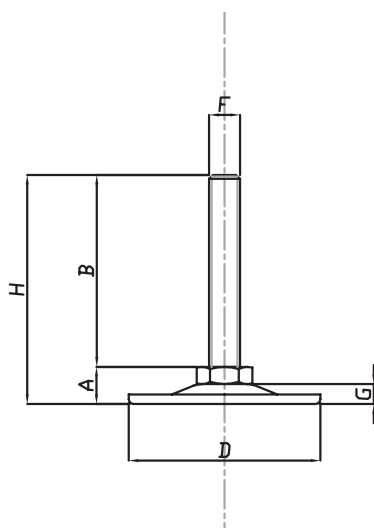

CODICE - CODE	descrizione - description	DIMENSIONI PRINCIPALI - MAIN DIMENSIONS						CARICO STATICO STATIC LOAD NEWTON
		B	D	F	A	H	G	
31250	M8x50	50	Ø50	M8	11,5	61,5	6	5000

- Base e stelo in acciaio zincato
- Galvanized iron base, articulated galvanized steel screw

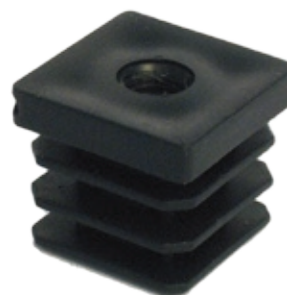
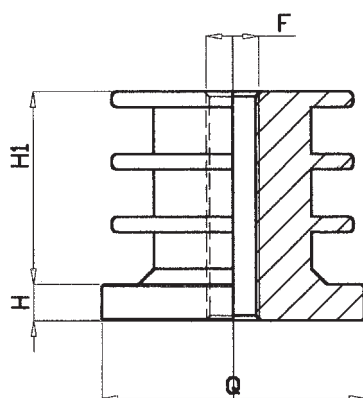

CODICE - CODE	descrizione - description	QUADRO ESTERNO EXTERNAL SQUARE Q	H	H1	FILETTO SCREW F
32100	Quadro 15x15 M10	15x15	5	18	M10
32101	Quadro 16x16 M10	16x16	5	18	M10
32102	Quadro 18x18 M10	18x18	5	18	M10
32103	Quadro 20x20 M10	20x20	5	18	M10
32104	Quadro 22x22 M10	22x22	5	18	M10
32105	Quadro 25x25 M10	25x25	5	19	M10
32106	Quadro 30x30 M10	30x30	6	20	M10
32107	Quadro 35x35 M10	35x35	6	21	M10
32108	Quadro 40x40 M10	40x40	6	22	M10
32109	Quadro 50x50 M10	50x50	7	30	M10

• Tappo di chiusura in poliammide per tubi quadrati.
A richiesta anche con M8

• I valori dei carichi sopra riportati sono calcolati in condizioni statiche. Qualora s'intendesse utilizzare i supporti in presenza di vibrazioni o carichi in movimento, tali valori dovranno essere adeguatamente ridotti. Per ulteriori chiarimenti consultare il nostro ufficio tecnico. Ogni nostra responsabilità decade in caso di manomissioni o modifiche dei componenti.

• *Polyamide plug for square tubes*
On request also with M8 available

• *Load values above mentioned have to be considered referring to static conditions calculated at the half of the screw length. In conditions of vibrations or in presence of dynamic loads these values should be reduced. For further information consult our technical office. We cannot accept responsibility for mounts that have been tampered or modified.*

TAPPO TONDO ROUND PLUG

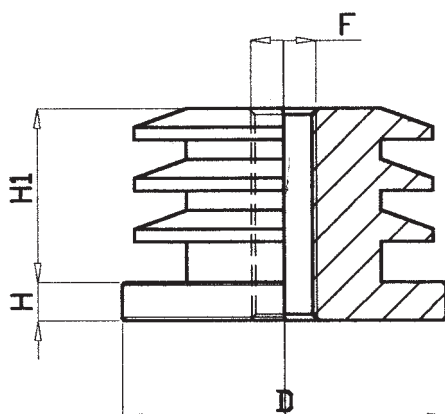

CODICE - CODE	descrizione - description	TONDO ESTERNO EXTERNAL ROUND D	H	H1	FILETTO SCREW F
32000	Ø 18 M10	18	6	18	M10
32001	Ø 20 M10	20	6	18	M10
32002	Ø 22 M10	22	6	19	M10
32003	Ø 25 M10	25	6	19	M10
32004	Ø 28 M10	28	6	19	M10
32006	Ø 30 M10	30	6	19	M10
32007	Ø 32 M10	32	6	19	M10
32008	Ø 35 M10	35	6	20	M10
32009	Ø 40 M10	40	6	20	M10
32010	Ø 45 M10	45	6	21	M10
32011	Ø 50 M10	50	6	21	M10

• Tappo di chiusura in poliammide per tubi tondi.
A richiesta anche con M8

• I valori dei carichi sopra riportati sono calcolati in condizioni statiche. Qualora s'intendesse utilizzare i supporti in presenza di vibrazioni o carichi in movimento, tali valori dovranno essere adeguatamente ridotti. Per ulteriori chiarimenti consultare il nostro ufficio tecnico. Ogni nostra responsabilità decade in caso di manomissioni o modifiche dei componenti.

• Polyamide plug for round tubes. On request also with M8 available

• Load values above mentioned have to be considered referring to static conditions calculated at the half of the screw length. In conditions of vibrations or in presence of dynamic loads these values should be reduced. For further information consult our technical office. We cannot accept responsibility for mounts that have been tampered or modified.

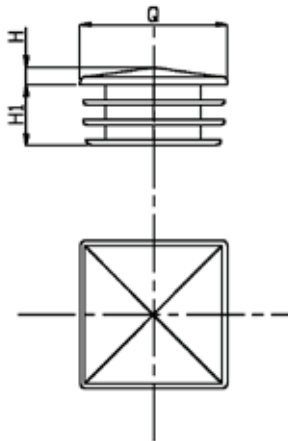

CODICE - CODE	descrizione - description	QUADRO ESTERNO EXTERNAL SQUARE Q	H	H1
33100	Quadro 25x25	25x25	6	20
33101	Quadro 30x30	30x30	6	21
33103	Quadro 35x35	35x35	6	21
33105	Quadro 40x40	40x40	6	21
33107	Quadro 50x50	50x50	6	21

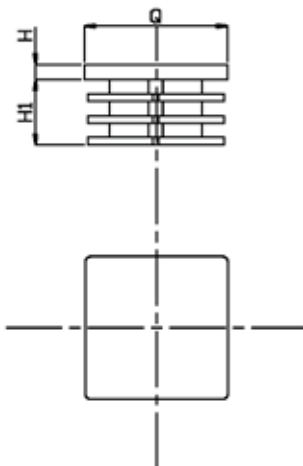

CODICE - CODE	descrizione - description	QUADRO ESTERNO EXTERNAL SQUARE Q	H	H1
34100	Quadro 25x25	25x25	5	20
34101	Quadro 30x30	30x30	5	21
34103	Quadro 35x35	35x35	4	21
34105	Quadro 40x40	40x40	4	21
34107	Quadro 50x50	50x50	5	21

• Tappo di chiusura in poliammide per tubi quadrati.

• Polyamide plug for square tubes.

TAPPO DI CHIUSURA TONDO ROUND PLUG

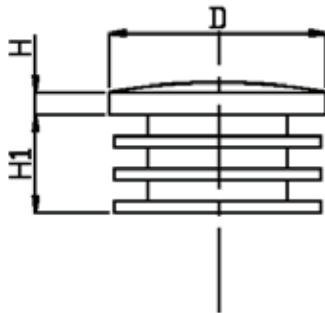

CODICE - CODE	descrizione - description	TONDO ESTERNO EXTERNAL ROUND D	H	H1
34200	Tondo Ø20	20	4	9,5
34202	Tondo Ø22	22	4	10
34204	Tondo Ø25	25	4	13
34206	Tondo Ø28	28	5	15
34208	Tondo Ø30	30	5	17
34210	Tondo Ø32	32	5	16
34212	Tondo Ø35	35	5	17
34214	Tondo Ø40	40	5	17
34216	Tondo Ø45	45	5	17
34218	Tondo Ø50	50	5	17
34220	Tondo Ø60	60	5	17

- Tappo di chiusura in poliammide per tubi tondi.
- I valori dei carichi sopra riportati sono calcolati in condizioni statiche. Qualora s'intendesse utilizzare i supporti in presenza di vibrazioni o carichi in movimento, tali valori dovranno essere adeguatamente ridotti. Per ulteriori chiarimenti consultare il nostro ufficio tecnico. Ogni nostra responsabilità decade in caso di manomissioni o modifiche dei componenti.
- *Polyamide plug for round tubes.*
- *Load values above mentioned have to be considered referring to static conditions calculated at the half of the screw length. In conditions of vibrations or in presence of dynamic loads these values should be reduced. For further information consult our technical office. We cannot accept responsibility for mounts that have been tampered or modified.*