

LINEA STAMPATA
PRESSED LINE

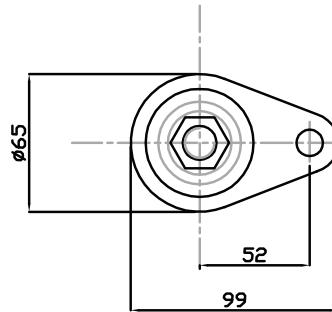

BASE STAMPATA ZINCATA Ø 65 CON 1-2 FORI – STELO FISSO O ARTICOLATO 8°
GALVANIZED STEEL PRESSED BASE Ø 65 WITH 1-2 HOLES
FIXED OR 8° ARTICULATED SCREW

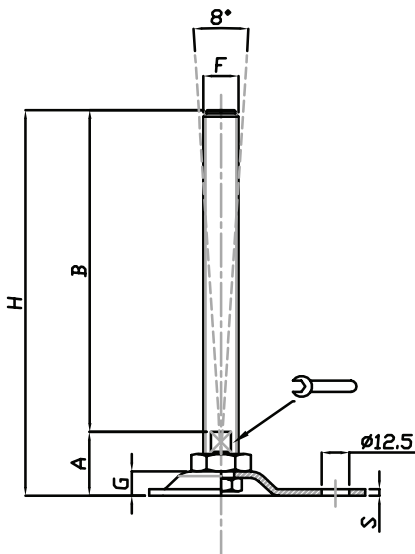

CODICE - CODE	descrizione description	DIMENSIONI PRINCIPALI - MAIN DIMENSIONS							CARICO STATICO STATIC LOAD NEWTON
		S	B	A	🔑	F	G	H	
15760	M16X150	3	150	29	13	M16	11	179	20000
15762	M16X200	3	200	29	13	M16	11	229	20000
15764	M20X150	3	150	32	17	M20	11	182	20000
15766	M20X200	3	200	32	17	M20	11	232	20000

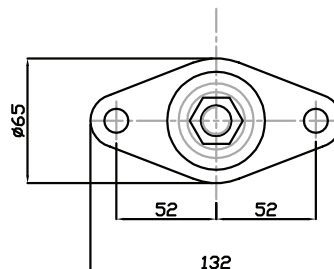
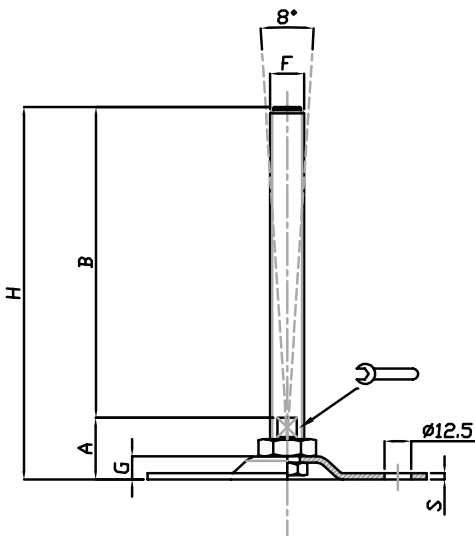

CODICE - CODE	descrizione description	DIMENSIONI PRINCIPALI - MAIN DIMENSIONS							CARICO STATICO STATIC LOAD NEWTON
		S	B	A	🔑	F	G	H	
15768	M12X100	3	100	28	10	M12	11	128	15000
15770	M12X150	3	150	28	10	M12	11	178	15000
15772	M16X100	3	100	29	13	M16	11	129	20000
15774	M16X150	3	150	29	13	M16	11	179	20000
15776	M16X200	3	200	29	13	M16	11	229	20000
15778	M20X150	3	150	32	17	M20	11	182	20000
15780	M20x200	3	200	32	17	M20	11	232	20000

• Base stampata in acciaio zincato FE. Stelo acciaio zincato FE. Su richiesta l'elemento di livellamento viene fornito con dado in acciaio

• Material: pressed base in galvanized steel. Galvanized steel screw. The levelling element could be supplied with steel nut.

BASE STAMPATA ZINCATA Ø 65 – STELO ARTICOLATO 8°
GALVANIZED STEEL PRESSED BASE Ø 65 – 8° ARTICULATED SCREW

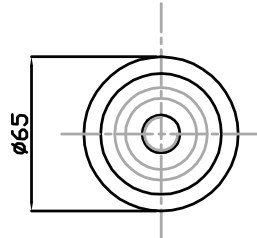
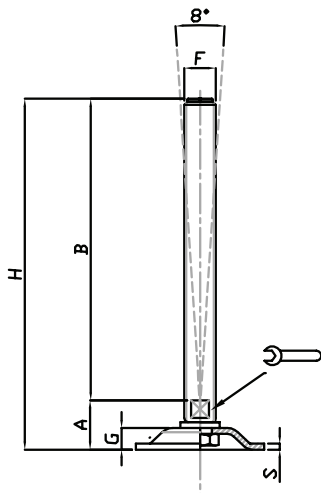

CODICE - CODE	descrizione description	DIMENSIONI PRINCIPALI - MAIN DIMENSIONS							CARICO STATICO STATIC LOAD NEWTON
		S	B	A	🔑	F	G	H	
15814	M12x100	3	100	22,50	10	M12	11	122,50	15000
15816	M12x150	3	150	22,50	10	M12	11	172,50	15000
15818	M16x100	3	100	22,50	13	M15	11	122,50	20000
15820	M16x150	3	150	22,50	13	M15	11	172,50	20000
15822	M16x200	3	200	22,50	13	M16	11	222,50	20000
15824	M20x150	3	150	24,50	17	M20	11	199	20000
15826	M20x200	3	200	24,50	17	M20	11	224,50	20000

BASE STAMPATA ZINCATA QUADRATA CON 4 FORI – STELO FISSO O ARTICOLATO 8°
SQUARE GALVANIZED STEEL PRESSED BASE WITH 4 HOLES – FIXED OR 8° ARTICULATED SCREW

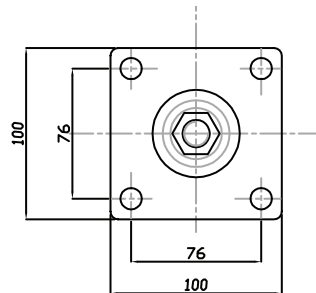
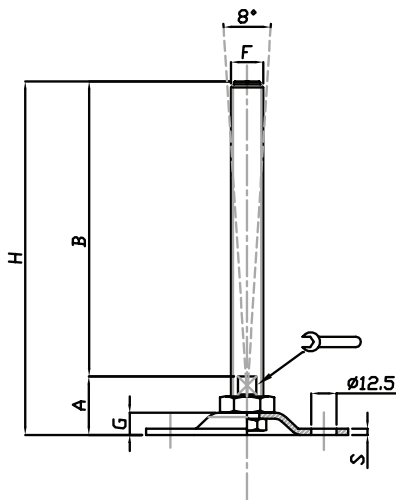



CODICE - CODE	descrizione description	DIMENSIONI PRINCIPALI - MAIN DIMENSIONS							CARICO STATICO STATIC LOAD NEWTON
		S	B	A	🔑	F	G	H	
15782	M16x150	3	150	29	13	M16	11	179	20000
15784	M16x200	3	200	29	13	M16	11	229	20000
15786	M20x150	3	150	32	17	M20	11	182	25000
15788	M20x200	3	200	32	17	M20	11	232	25000
15790	M24x150	3	150	32	20	M24	11	182	30000
15792	M24x200	3	200	32	20	M24	11	232	30000

• Base stampata in acciaio zincato FE. Stelo acciaio zincato FE. Su richiesta l'elemento di livellamento viene fornito con dado in acciaio.

• Material: galvanized steel base. Galvanized steel screw. The levelling element could be supplied with steel nut.

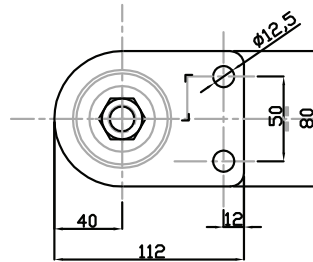
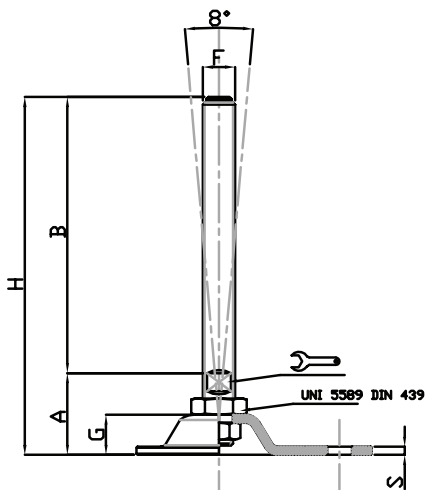
BASE STAMPATA ZINCATA Ø 80 X 112 CON 2 FORI
GALVANIZED STEEL PRESSED BASE Ø 80 X 112 WITH 2 FIXING HOLES



CODICE - CODE	descrizione description	DIMENSIONI PRINCIPALI - MAIN DIMENSIONS							CARICO STATICO STATIC LOAD NEWTON
		S	B	A		F	G	H	
15660Z/FIX	M16X150	3	150	39.5	13	M16	19	189.5	20000
15662Z/FIX	M16X200	3	200	39.5	13	M16	19	239.5	20000
15664Z/FIX	M20X150	3	150	40.5	17	M20	19	190.5	20000
15666Z/FIX	M20X200	3	200	40.5	17	M20	19	240.5	20000

BASE STAMPATA ZINCATA Ø 110 X 151 CON 2 FORI
GALVANIZED STEEL PRESSED BASE Ø 110 X 151 WITH 2 FIXING HOLES

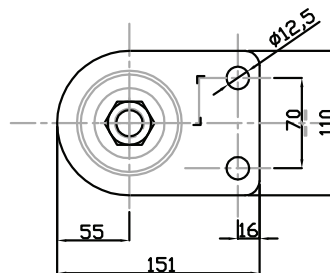
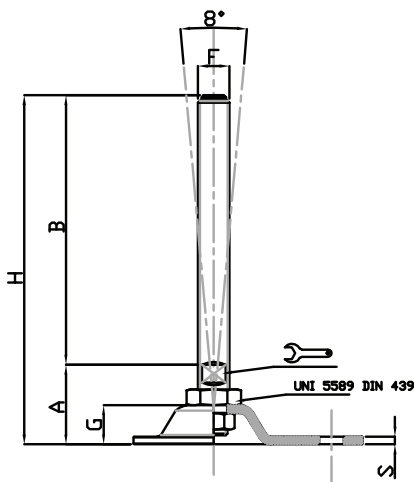

CODICE - CODE	descrizione description	DIMENSIONI PRINCIPALI - MAIN DIMENSIONS							CARICO STATICO STATIC LOAD NEWTON
		S	B	A		F	G	H	
15670Z/FIX	M16X150	4	150	41	17	M16	19	191	25000
15672Z/FIX	M16X200	4	200	41	17	M16	19	241	25000
15674Z/FIX	M20X150	4	150	42	17	M20	19	192	25000
15678Z/FIX	M20X200	4	200	42	17	M20	19	242	25000
15680Z/FIX	M24X150	4	150	43	20	M24	19	193	30000
15682Z/FIX	M24X200	4	200	43	20	M24	19	243	30000

• Base stampata in acciaio zincato FE. Stelo acciaio zincato FE. Su richiesta l'elemento di livellamento viene fornito con dado in acciaio

• Material: pressed base in galvanized steel. Galvanized steel screw. The levelling element could be supplied with steel nut.

BASE STAMPATA ZINCATA Ø 85 – STELO ARTICOLATO 8°
GALVANIZED STEEL PRESSED BASE Ø 85 – 8° ARTICULATED SCREW

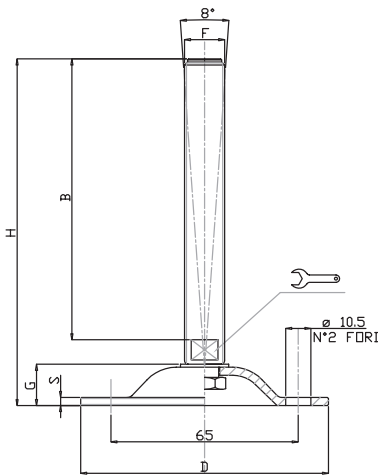

CODICE - CODE	descrizione description	DIMENSIONI PRINCIPALI - MAIN DIMENSIONS							CARICO STATICO STATIC LOAD NEWTON
		S	B	D	🔑	F	G	H	
15828	M16X100	3	100	85	13	M16	13	125	15000
15830	M16X150	3	150	85	13	M16	13	175	15000
15832	M16X175	3	175	85	13	M16	13	200	15000
15834	M20X100	3	100	85	17	M20	13	125	15000
15836	M20X150	3	150	85	17	M20	13	175	15000
15838	M20X200	3	200	85	17	M20	13	225	15000

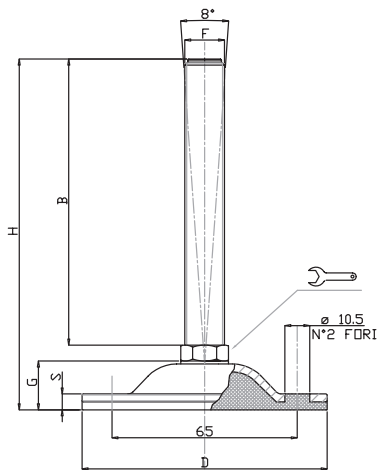

CODICE - CODE	descrizione description	DIMENSIONI PRINCIPALI - MAIN DIMENSIONS							CARICO STATICO STATIC LOAD NEWTON
		S	B	D	🔑	F	G	H	
15828/V	M16X100	8	100	85	16	M16	17	126	15000
15830/V	M16X150	8	150	85	16	M16	17	176	15000
15832/V	M16X175	8	175	85	16	M16	17	201	15000
15834/V	M20X100	8	100	85	20	M20	17	126	15000
15836/V	M20X150	8	150	85	20	M20	17	176	15000
15838/V	M20X200	8	200	85	20	M20	17	226	15000

- Base stampata in acciaio zincato FE. Stelo acciaio zincato FE. Su richiesta l'elemento di livellamento viene fornito con dado in acciaio
- Gomma NBR 80 shore

- Material: pressed base in galvanized steel. Galvanized steel screw. The levelling element could be supplied with steel nut.
- Vulcanized rubber pad NBR 80 shore

BASE STAMPATA ZINCATA/CATAFORESI NERA Ø 124 CON 4 FORI, STELO ZINCATO SNODATO 8°

GALVANIZED STEEL/BLACK CATAPHORESIS PRESSED BASE Ø 124 WITH 4 FIXING HOLES, ARTICULATED STEEL SCREW 8°

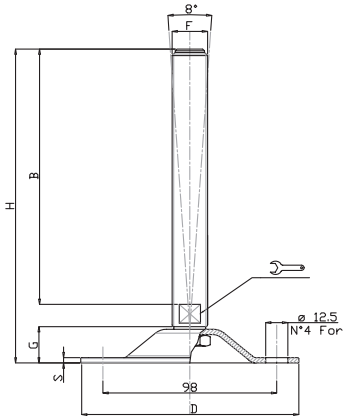

CODICE - CODE		descrizione	DIMENSIONI PRINCIPALI - MAIN DIMENSIONS							CARICO STATICO
standard	cataforesi nero	description	S	B	D	🔑	F	G	H	STATIC LOAD
standard	black cataphoresis									NEWTON
15600Z	15602C	M16X100	4	100	124	17	M16	20,5	134	20000
15604Z	15606C	M16X150	4	150	124	17	M16	20,5	184	20000
15608Z	15610C	M16X175	4	175	124	17	M16	20,5	209	20000
15612Z	15614C	M20X100	4	100	124	17	M20	20,5	134	25000
15616Z	15618C	M20X150	4	150	124	17	M20	20,5	184	25000
15620Z	15622C	M20X175	4	175	124	17	M20	20,5	209	25000
15624Z	15626C	M20X200	4	200	124	17	M20	20,5	234	25000
15628Z	15630C	M24X100	4	100	124	20	M24	20,5	134	30000
15632Z	15634C	M24X150	4	150	124	20	M24	20,5	184	30000
15636Z	15638C	M24X200	4	200	124	20	M24	20,5	234	30000
15640Z	15642C	M30X150	4	150	124	26	M30	20,5	185	35000
15644Z	15646C	M30X200	4	200	124	26	M30	20,5	235	35000
15648Z	15650C	M30X250	4	250	124	26	M30	20,5	285	35000

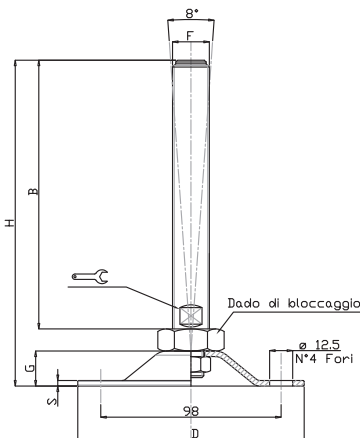

CODICE - CODE		descrizione	DIMENSIONI PRINCIPALI - MAIN DIMENSIONS							CARICO STATICO
		description	S	B	D	🔑	F	G	H	STATIC LOAD
										NEWTON
15604Z/FIX		M16X150	4	150	124	17	M16	20.5	184	20000
15611Z/FIX		M16X200	4	200	124	17	M16	20.5	234	20000
15616Z/FIX		M20X150	4	150	124	17	M20	20.5	184	25000
15624Z/FIX		M20X200	4	200	124	17	M20	20.5	234	25000
15632Z/FIX		M24X150	4	150	124	20	M24	20.5	184	30000
15636Z/FIX		M24X200	4	200	124	20	M24	20.5	234	30000

• Base stampata in acciaio zincato FE o cataforesi nera. Il trattamento di cataforesi della base garantisce un'ottima resistenza all'aggressione di solventi, sgrassanti chimici e lavaggi industriali. Stelo acciaio zincato FE. Su richiesta l'elemento di livellamento viene fornito con dado in acciaio

• Material: pressed base in galvanized steel or black cataphoresis. The cataphoresis treatment of the surface grants an excellent resistance against solvents and chemical agents. Galvanized steel screw. The levelling element could be supplied with steel nut.

BASE STAMPATA ZINCATA Ø 124 CON GOMMA VULCANIZZATA, STELO ZINCATO SNODATO 8°

GALVANIZED STEEL PRESSED BASE Ø 124 WITH VULCANIZED RUBBER,
ARTICULATED STEEL SCREW 8°

Martin
Levelling Components

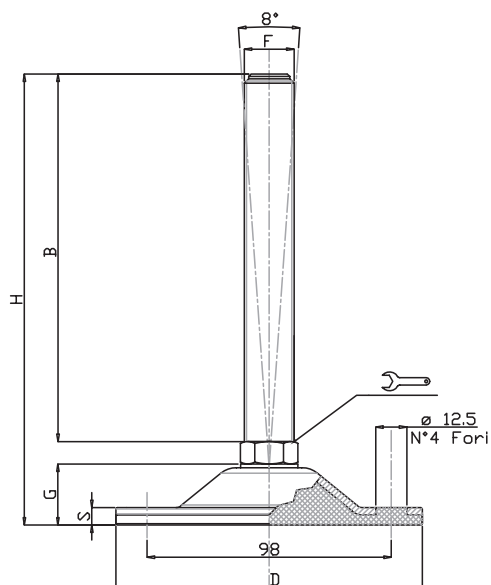

CODICE - CODE	descrizione	DIMENSIONI PRINCIPALI - MAIN DIMENSIONS							CARICO STATICO STATIC LOAD NEWTON
		S	B	D	🔑	F	G	H	
zincato - galvanized iron	description								
15600Z/V	M16X100	8	100	124	16	M16	23,5	132	20000
15604Z/V	M16X150	8	150	124	16	M16	23,5	182	20000
15608Z/V	M16X175	8	175	124	16	M16	23,5	207	20000
15612Z/V	M20X100	8	100	124	20	M20	23,5	132	20000
15616Z/V	M20X150	8	150	124	20	M20	23,5	182	20000
15620Z/V	M20X175	8	175	124	20	M20	23,5	207	20000
15624Z/V	M20X200	8	200	124	20	M20	23,5	232	20000
15628Z/V	M24X100	8	100	124	24	M24	23,5	132	20000
15632Z/V	M24X150	8	150	124	24	M24	23,5	182	20000
15636Z/V	M24X200	8	200	124	24	M24	23,5	232	20000
15640Z/V	M30X150	8	150	124	30	M30	23,5	183	20000
15644Z/V	M30X200	8	200	124	30	M30	23,5	233	20000
15648Z/V	M30X250	8	250	124	30	M30	23,5	283	20000

• Base stampata in acciaio zincato FE. Possibilità di forare la base ottenendo così 4 fori per il fissaggio. Gomma vulcanizzata NBR 80 shore. Stelo acciaio zincato FE. Su richiesta l'elemento di livellamento viene fornito con dado in acciaio.

• I valori dei carichi sopra riportati sono calcolati in condizioni statiche alla metà della lunghezza dello stelo filettato. Qualora s'intendesse utilizzare i supporti in presenza di vibrazioni o carichi in movimento, tali valori dovranno essere adeguatamente ridotti. Per ulteriori chiarimenti consultare il nostro ufficio tecnico. Ogni nostra responsabilità decade in caso di manomissioni o modifiche dei componenti.

• *Material: galvanized steel base. Possibility to drill the rubber to obtain 4 fixing holes. Pad: vulcanized rubber NBR 80 shore. Galvanized steel screw. The levelling element could be supplied with steel nut.*

• *Load values above mentioned have to be considered referring to static conditions calculated at the half of the screw length. In conditions of vibrations or in presence of dynamic loads these values should be reduced. For further information consult our technical office. We cannot accept responsibility for mounts that have been tampered or modified*

BASE STAMPATA INOX Ø 65 CON 1-2 FORI – STELO FISSO O ARTICOLATO 8°
STAINLESS STEEL PRESSED BASE Ø 65 WITH 1-2 HOLES
FIXED OR 8° ARTICULATED SCREW

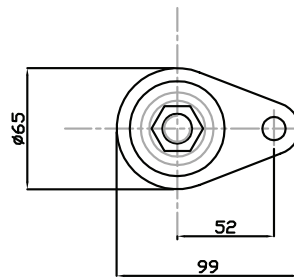
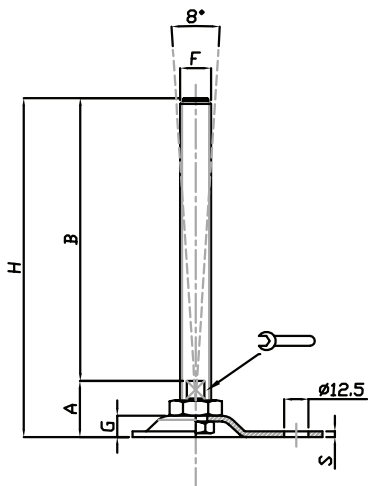

CODICE - CODE	descrizione description	DIMENSIONI PRINCIPALI - MAIN DIMENSIONS							CARICO STATICO STATIC LOAD NEWTON
		S	B	A	🔑	F	G	H	
15840	M16x150	3	150	29	13	M16	11	179	20000
15842	M16x200	3	200	29	13	M16	11	229	20000
15844	M20x150	3	150	32	17	M20	11	182	20000
15846	M20x200	3	200	32	17	M20	11	232	20000

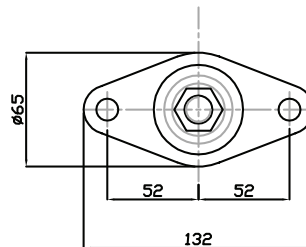
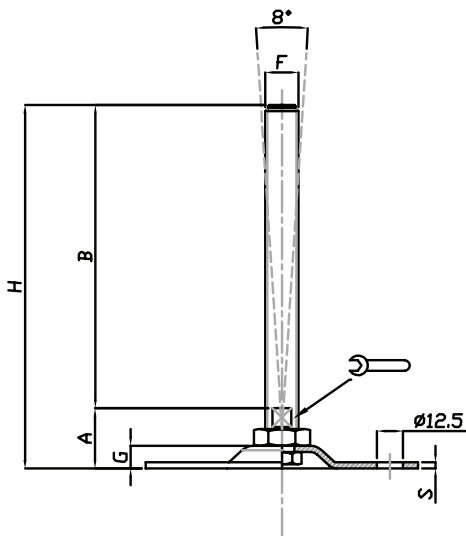



CODICE - CODE	descrizione description	DIMENSIONI PRINCIPALI - MAIN DIMENSIONS							CARICO STATICO STATIC LOAD NEWTON
		S	B	A	🔑	F	G	H	
15848	M12x100	3	100	28	10	M12	11	128	15000
15850	M12x150	3	150	28	10	M12	11	178	15000
15852	M16x100	3	100	29	13	M16	11	129	20000
15854	M16x150	3	150	29	13	M16	11	179	20000
15856	M16x200	3	200	29	13	M16	11	229	20000
15858	M20x150	3	150	32	17	M20	11	182	20000
15860	M20x200	3	200	32	17	M20	11	232	20000

• Base stampata in acciaio inox AISI 304. Stelo acciaio inox AISI 304. Su richiesta l'elemento di livellamento viene fornito con dado in acciaio

• Material: stainless steel base 1.4301. Stainless steel screw 1.4301. The levelling element could be supplied with steel nut.

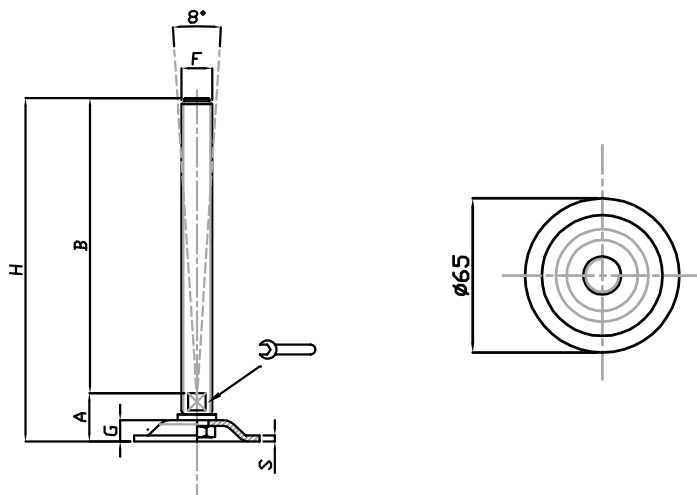
BASE STAMPATA INOX Ø 65 – STELO ARTICOLATO 8°
STAINLESS STEEL PRESSED BASE Ø 65 – 8° ARTICULATED SCREW



CODICE - CODE	descrizione description	DIMENSIONI PRINCIPALI - MAIN DIMENSIONS							CARICO STATICO STATIC LOAD NEWTON
		S	B	A		F	G	H	
15874	M12X100	3	100	22,50	10	M12	11	122,50	15000
15876	M12X150	3	150	22,50	10	M12	11	172,50	15000
15878	M16X100	3	100	22,50	13	M16	11	122,50	20000
15880	M16X150	3	150	22,50	13	M16	11	172,50	20000
15882	M16X200	3	200	22,50	13	M16	11	222,50	20000
15884	M20X150	3	150	24,50	17	M20	11	199	20000
15886	M20X200	3	200	24,50	17	M20	11	224,50	20000

BASE STAMPATA INOX QUADRATA CON 4 FORI – STELO FISSO O ARTICOLATO 8°
SQUARE STAINLESS STEEL PRESSED BASE WITH 4 HOLES – FIXED OR 8° ARTICULATED SCREW

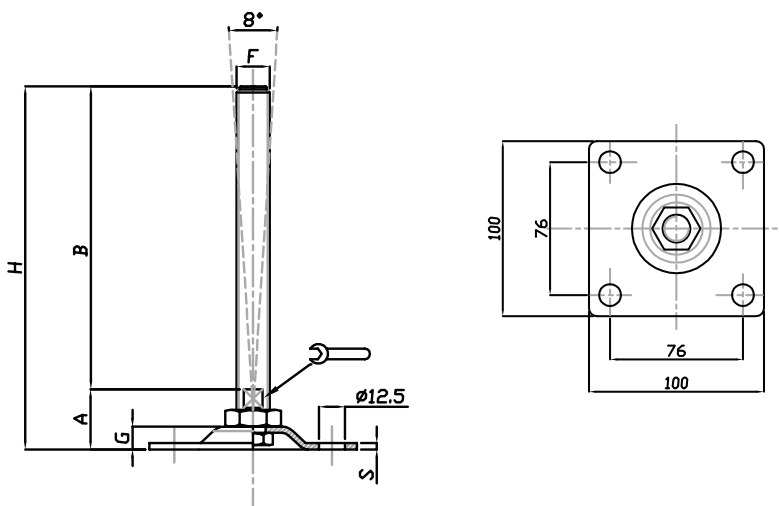

CODICE - CODE	descrizione description	DIMENSIONI PRINCIPALI - MAIN DIMENSIONS							CARICO STATICO STATIC LOAD NEWTON
		S	B	A		F	G	H	
15862	M16x150	3	150	29	13	M16	11	179	20000
15864	M16x200	3	200	29	13	M16	11	229	20000
15866	M20x150	3	150	32	17	M20	11	182	25000
15868	M20x200	3	200	32	17	M20	11	232	25000
15870	M24x150	3	150	32	20	M24	11	182	30000
15872	M24x200	3	200	32	20	M24	11	232	30000

• Base stampata in acciaio inox AISI 304. Stelo acciaio inox AISI 304. Su richiesta l'elemento di livellamento viene fornito con dado in acciaio

• Material: stainless steel base 1.4301. Stainless steel screw 1.4301. The levelling element could be supplied with steel nut.

BASE STAMPATA INOX Ø 80 X 112 CON 2 FORI
STAINLESS STEEL PRESSED BASE Ø 80 X 112 WITH 2 FIXING HOLES

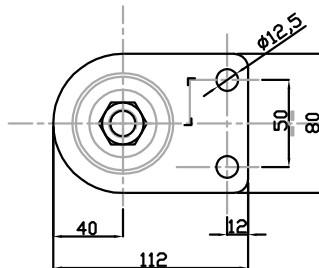
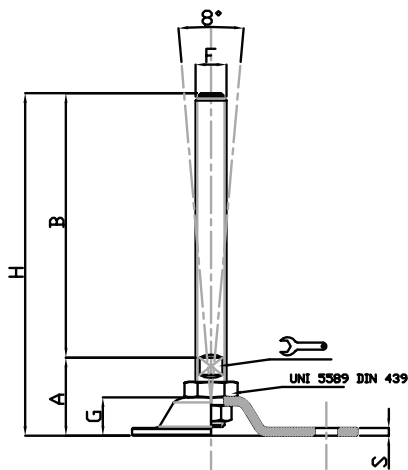

CODICE - CODE	descrizione description	DIMENSIONI PRINCIPALI - MAIN DIMENSIONS							CARICO STATICO STATIC LOAD NEWTON
		S	B	A	🔧	F	G	H	
15730/FIX	M16X150	3	150	39.5	13	M16	19	189.5	20000
15732/FIX	M16X200	3	200	39.5	13	M16	19	239.5	20000
15734/FIX	M20X150	3	150	40.5	17	M20	19	190.5	20000
15736/FIX	M20X200	3	200	40.5	17	M20	19	240.5	20000

BASE STAMPATA INOX Ø 110 X 151 CON 2 FORI
STAINLESS STEEL PRESSED BASE Ø 110 X 151 WITH 2 FIXING HOLES

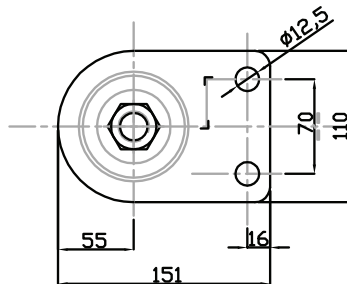
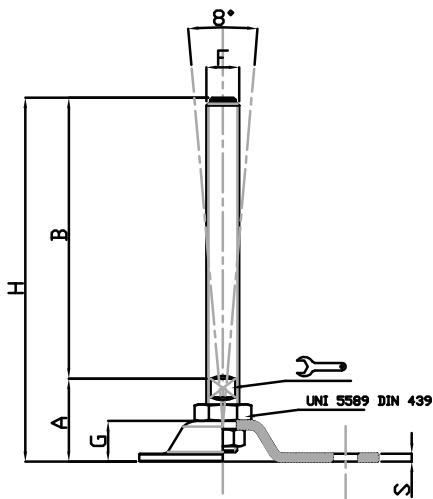



CODICE - CODE	descrizione description	DIMENSIONI PRINCIPALI - MAIN DIMENSIONS							CARICO STATICO STATIC LOAD NEWTON
		S	B	A	🔧	F	G	H	
15740/FIX	M16X150	4	150	41	17	M16	19	191	25000
15742/FIX	M16X200	4	200	41	17	M16	19	241	25000
15744/FIX	M20X150	4	150	42	17	M20	19	192	25000
15746/FIX	M20X200	4	200	42	17	M20	19	242	25000
15748/FIX	M24X150	4	150	43	20	M24	19	193	30000
15750/FIX	M24X200	4	200	43	20	M24	19	243	30000

• Base stampata in acciaio inox AISI 304. Stelo acciaio inox AISI 304. Su richiesta l'elemento di livellamento viene fornito con dado in acciaio

• Material: stainless steel base 1.4301. Stainless steel screw 1.4301. The levelling element could be supplied with steel nut.

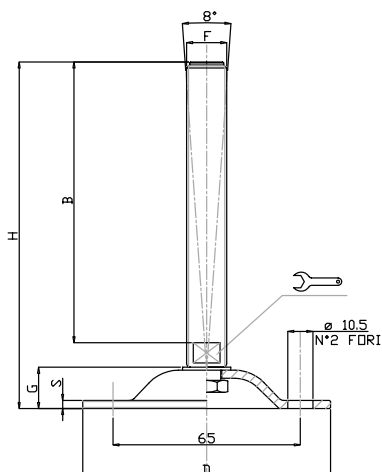
BASE STAMPATA INOX Ø 85 – STELO ARTICOLATO 8°
STAINLESS STEEL PRESSED BASE Ø 85 – 8° ARTICULATED SCREW



CODICE - CODE	descrizione description	DIMENSIONI PRINCIPALI - MAIN DIMENSIONS							CARICO STATICO STATIC LOAD NEWTON
		S	B	D		F	G	H	
15688	M16X100	3	100	85	13	M16	13	125	15000
15690	M16X150	3	150	85	13	M16	13	175	15000
15692	M16X175	3	175	85	13	M16	13	200	15000
15694	M20X100	3	100	85	17	M20	13	125	15000
15696	M20X150	3	150	85	17	M20	13	175	15000
15698	M20X200	3	200	85	17	M20	13	225	15000

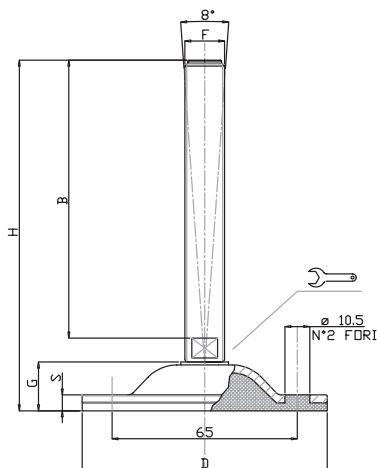

CODICE - CODE	descrizione description	DIMENSIONI PRINCIPALI - MAIN DIMENSIONS							CARICO STATICO STATIC LOAD NEWTON
		S	B	D		F	G	H	
15688/V	M16X100	8	100	85	13	M16	16	128	15000
15690/V	M16X150	8	150	85	13	M16	16	178	15000
15692/V	M16X175	8	175	85	13	M16	16	203	15000
15694/V	M20X100	8	100	85	17	M20	16	128	15000
15696/V	M20X150	8	150	85	17	M20	16	178	15000
15698/V	M20X200	8	200	85	17	M20	16	228	15000

- Base stampata in acciaio inox AISI 304. Stelo acciaio inox AISI 304. Su richiesta l'elemento di livellamento viene fornito con dado in acciaio
- Gomma NBR 80 shore
- Material: stainless steel base 1.4301. Stainless steel screw 1.4301. The levelling element could be supplied with steel nut.
- Vulcanized rubber pad NBR 80 shore

BASE STAMPATA INOX Ø 123 CON 4 FORI, STELO INOX SNODATO 8°
STAINLESS STEEL PRESSED BASE Ø 123 WITH 4 FIXING HOLES
ARTICULATED STAINLESS STEEL SCREW 8°

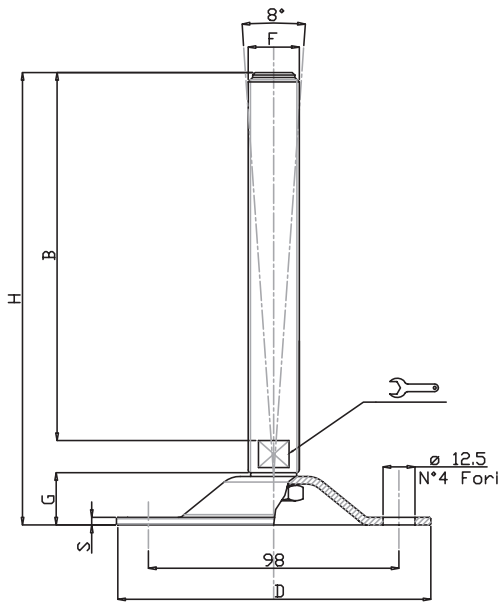

CODICE - CODE	descrizione description	DIMENSIONI PRINCIPALI - MAIN DIMENSIONS							CARICO STATICO STATIC LOAD NEWTON
		S	B	D	🔑	F	G	H	
15700	M16X100	4	100	Ø 123	17	M16	20,5	134	20000
15702	M16X150	4	150	Ø 123	17	M16	20,5	184	20000
15704	M16X175	4	175	Ø 123	17	M16	20,5	209	20000
15706	M20X100	4	100	Ø 123	17	M20	20,5	134	25000
15708	M20X150	4	150	Ø 123	17	M20	20,5	184	25000
15710	M20X200	4	200	Ø 123	17	M20	20,5	234	25000
15712	M24X100	4	100	Ø 123	20	M24	20,5	134	30000
15714	M24X150	4	150	Ø 123	20	M24	20,5	184	30000
15716	M24X200	4	200	Ø 123	20	M24	20,5	234	30000
15718	M30X150	4	150	Ø 123	26	M30	20,5	185	35000
15720	M30X200	4	200	Ø 123	26	M30	20,5	235	35000
15722	M30X250	4	250	Ø 123	26	M30	20,5	285	35000

- Base stampata in acciaio inox AISI 304. Stelo acciaio inox AISI 304. Su richiesta l'elemento di livellamento viene fornito con dado in acciaio
- I valori dei carichi sopra riportati sono calcolati in condizioni statiche alla metà della lunghezza dello stelo filettato. Qualora s'intendesse utilizzare i supporti in presenza di vibrazioni o carichi in movimento, tali valori dovranno essere adeguatamente ridotti. Per ulteriori chiarimenti consultare il nostro ufficio tecnico. Ogni nostra responsabilità decade in caso di manomissioni o modifiche dei componenti.
- *Material: stainless steel base 1.4301. Stainless steel screw 1.4301. The levelling element could be supplied with steel nut.*
- *Load values above mentioned have to be considered referring to static conditions calculated at the half of the screw length. In conditions of vibrations or in presence of dynamic loads these values should be reduced. For further information consult our technical office. We cannot accept responsibility for mounts that have been tampered or modified*

BASE STAMPATA INOX Ø 123 CON GOMMA VULCANIZZATA, STELO INOX SNODATO 8°

STAINLESS STEEL PRESSED BASE Ø 123 WITH VULCANIZED RUBBER,
ARTICULATED STAINLESS STEEL SCREW 8°

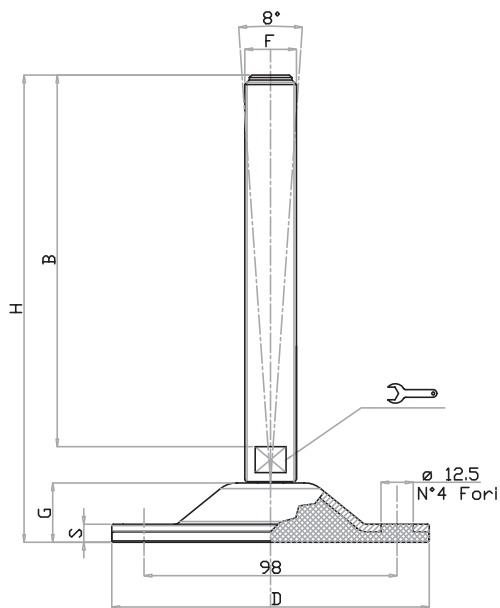

CODICE - CODE	descrizione description	DIMENSIONI PRINCIPALI - MAIN DIMENSIONS							CARICO STATICO STATIC LOAD NEWTON
		S	B	D	🔑	F	G	H	
15700/V	M16X100	7	100	Ø 123	13	M16	23,5	137	20000
15702/V	M16X150	7	150	Ø 123	13	M16	23,5	187	20000
15704/V	M16X175	7	175	Ø 123	13	M16	23,5	212	20000
15706/V	M20X100	7	100	Ø 123	17	M20	23,5	137	20000
15708/V	M20X150	7	150	Ø 123	17	M20	23,5	187	20000
15710/V	M20X200	7	200	Ø 123	17	M20	23,5	237	20000
15712/V	M24X100	7	100	Ø 123	20	M24	23,5	138	20000
15714/V	M24X150	7	150	Ø 123	20	M24	23,5	188	20000
15716/V	M24X200	7	200	Ø 123	20	M24	23,5	238	20000
15718/V	M30X150	7	150	Ø 123	26	M30	23,5	188	20000
15720/V	M30X200	7	200	Ø 123	26	M30	23,5	238	20000
15722/V	M30X250	7	250	Ø 123	26	M30	23,5	288	20000

- Base stampata in acciaio inox AISI 304. Possibilità di forare la base ottenendo così 4 fori per il fissaggio. Gomma vulcanizzata NBR 80 shore. Stelo acciaio inox AISI 304. Su richiesta l'elemento di livellamento viene fornito con dado in acciaio
- I valori dei carichi sopra riportati sono calcolati in condizioni statiche alla metà della lunghezza dello stelo filettato. Qualora s'intendesse utilizzare i supporti in presenza di vibrazioni o carichi in movimento, tali valori dovranno essere adeguatamente ridotti. Per ulteriori chiarimenti consultare il nostro ufficio tecnico. Ogni nostra responsabilità decade in caso di manomissioni o modifiche dei componenti.
- *Material: stainless steel 1.4301 base. Possibility to drill the rubber to obtain fixing holes. Pad: vulcanized rubber NBR 80 shore. Stainless steel screw 1.4301. The levelling element could be supplied with steel nut.*
- *Load values above mentioned have to be considered referring to static conditions calculated at the half of the screw length. In conditions of vibrations or in presence of dynamic loads these values should be reduced. For further information consult our technical office. We cannot accept responsibility for mounts that have been tampered or modified*