

LINEA TEKNOFIX
TEKNOFIX LINE

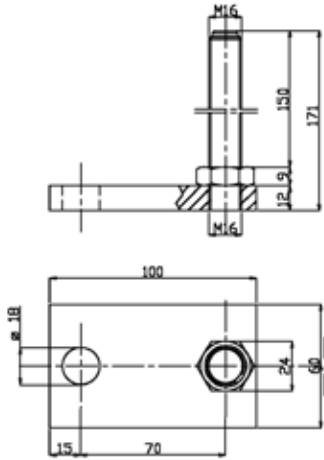

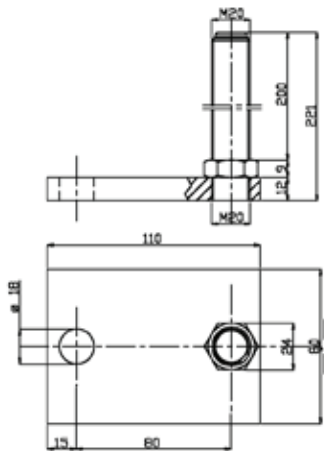



CODICE - CODE	DIMENSIONE BASE BASE DIMENSION	DIMENSIONE STELO SCREW DIMENSION		F	CARICO STATICO STATIC LOAD NEWTON
19000	100X60 H12	M16X150	24	M16	30000

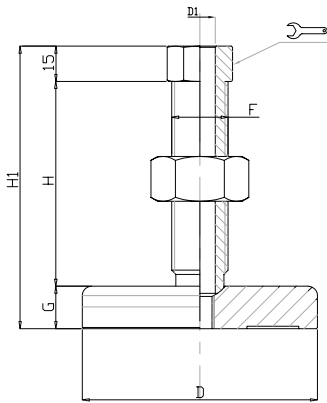

CODICE - CODE	DIMENSIONE BASE BASE DIMENSION	DIMENSIONE STELO SCREW DIMENSION		F	CARICO STATICO STATIC LOAD NEWTON
19001	110X80 H12	M20X200	24	M20	40000

- Materiale base: acciaio zincato C40. Materiale stelo: acciaio zincato FE. Su richiesta l'elemento di livellamento viene fornito con dado in acciaio
- I valori dei carichi sopra riportati sono calcolati in condizioni statiche alla metà della lunghezza dello stelo filettato. Qualora s'intendesse utilizzare i supporti in presenza di vibrazioni o carichi in movimento, tali valori dovranno essere adeguatamente ridotti. Per ulteriori chiarimenti consultare il nostro ufficio tecnico. Ogni nostra responsabilità decade in caso di manomissioni o modifiche dei componenti.
- Galvanized steel base (C40). Fixed galvanized steel screw. The leveling element could be supplied, on request, with steel nut.
- Load values above mentioned have to be considered referring to static conditions calculated at the half of the screw length. In conditions of vibrations or in presence of dynamic loads these values should be reduced. For further information consult our technical office. We cannot accept responsibility for mounts that have been tampered or modified



CODICE - CODE standard - standard	DIMENSIONI PRINCIPALI - MAIN DIMENSIONS							CARICO STATICO STATIC LOAD NEWTON
	D	D1		F	G	H	H1	
12620 V	Ø 100	Ø 13	24	M24X2	18	141	174	60000
12620 F	Ø 100	Ø 13	24	M24X2	18	141	174	60000
12621 V	Ø 100	Ø 13	24	M24X2	18	87	120	60000
12621 F	Ø 100	Ø 13	24	M24X2	18	87	120	60000
12617 V	Ø 120	Ø 22	41	M35X2	25	100	140	90000
12617 F	Ø 120	Ø 22	41	M35X2	25	100	140	90000
12618 V	Ø 120	Ø 22	41	M36X2	25	100	140	90000
12618 F	Ø 120	Ø 22	41	M36X2	25	100	140	90000
12619 V	Ø 120	Ø 22	41	M35X2	25	177	217	90000
12619 F	Ø 120	Ø 22	41	M35X2	25	177	217	90000
12623 V	Ø 150	Ø 22	41	M35X2	25	100	140	90000
12623 F	Ø 150	Ø 22	41	M35X2	25	100	140	90000
12624 V	Ø 150	Ø 22	41	M36X2	25	100	140	90000
12624 F	Ø 150	Ø 22	41	M36X2	25	100	140	90000
12625 V	Ø 150	Ø 22	41	M35X2	25	177	217	90000
12625 F	Ø 150	Ø 22	41	M35X2	25	177	217	90000

Codice + V = finitura verniciata
Codice + F = finitura fosfatata

"V" CODE = surface finishing: yellow painted
"F" CODE = surface finishing: phosphated

TEKNOFIX CNC

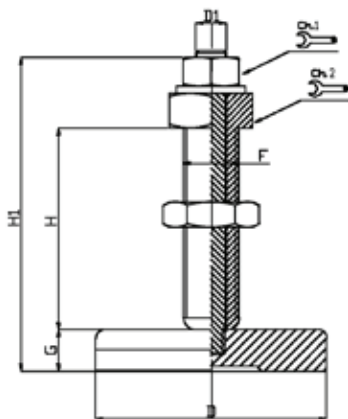



CODICE - CODE standard - standard	DIMENSIONI PRINCIPALI - MAIN DIMENSIONS							CARICO STATICO STATIC LOAD NEWTON
	D	D1	CH1/CH2	F	G	H	H1	
12622	Ø 80	Ø 16	24 36	M30X2	20	75	126	70000
12627	Ø 68	Ø 12	19 27	M27X2	25	78	134	65000

• Materiale base: acciaio verniciato/ fosfatato. Materiale stelo forato: acciaio zincato / fosfatato
• Applicazioni: macchine assemblaggio; macchine utensili e linee d'automazione. Teknofix consente il livellamento della struttura anche dopo il fissaggio a terra.

• Material of the base: painted/burnished steel. Material of the drilled screw: galvanized / burnished steel
• Application: assembling machines, machine tools, automation-lines. Features: the system allows the put on level of the machine after its fastening to the ground

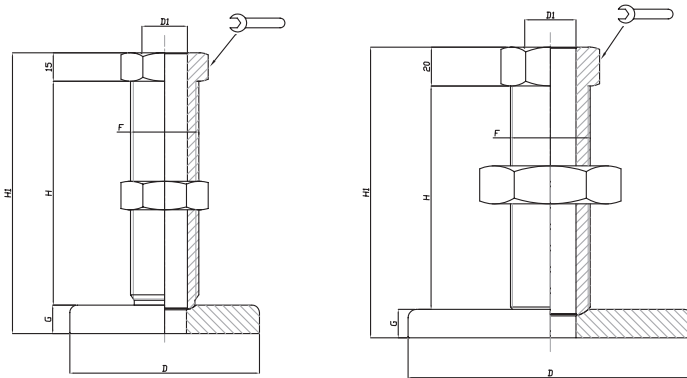
TEKNOFIX



CODICE - CODE	D	D1		F	G	H	H1	CARICO STATICO STATIC LOAD NEWTON
12628	Ø 150	27	45	M42x2	15	119	154	100000
12629	Ø 100	22	41	M36x3	15	118	148	90000

PIEDE ZINCATO GALVANIZED STEEL FOOT Ø 90

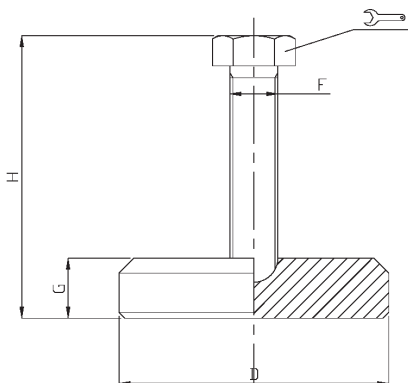



CODICE - CODE	D		F	G	H	CARICO STATICO STATIC LOAD NEWTON
12345	Ø 90	24	16	20	60	35000
12347	Ø 90	24	16	20	80	35000

- Materiale base: acciaio zincato C40.
Materiale stelo: acciaio brunito.

- Galvanized steel base (C40).
Burnished screw.

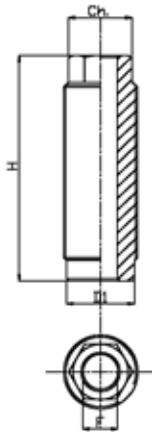
VITE A REGISTRO IN ACCIAIO STEEL ADJUSTING SCREWS



CODICE - CODE	DIMENSIONE BASE BASE DIMENSION	H		D1	F	CARICO STATICO STATIC LOAD NEWTON
19100Z	M30X2	110	24	27	17	70000
19100F	M30X2	110	24	27	17	70000
19101Z	M36X2	110	27	33	17	90000
19101F	M36X2	110	27	33	17	90000

Codice + Z = finitura zincata
Codice + F = finitura fosfatata

""Z" CODE = surface finishing: zinc
"F" CODE = surface finishing: phosphated

- Materiale: acciaio zincato FE. Applicazioni: macchine utensili, basamenti macchina
- Material: galvanized steel. Application: machine tools, machine beds a.s.o.

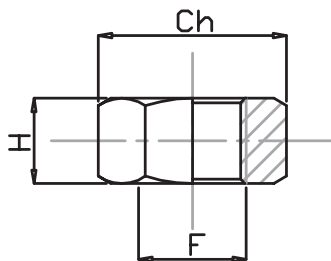

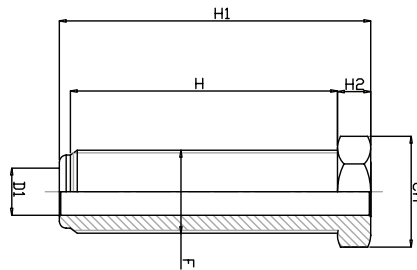

CODICE - CODE		F	CH	H
ZINCATA	FOSFATATA			
DD24X2Z	DD24X2F	M24x2	36	18
DD27X2Z	DD27X2F	M27x2	41	12
DD30X2Z	DD30X2F	M30x2	36	11
DD35X2Z	DD35X2F	M35x2	55	15
DD36X2Z	DD36X2F	M36x2	55	15
DD36X3Z	DD36X3F	M36x3	55	15
DD42X2Z	DD42X2F	M42x2	65	20

- Materiale: acciaio zincato FE. Applicazioni: macchine utensili, basamenti macchina
- Material: galvanized steel. Application: machine tools, machine beds a.s.o.



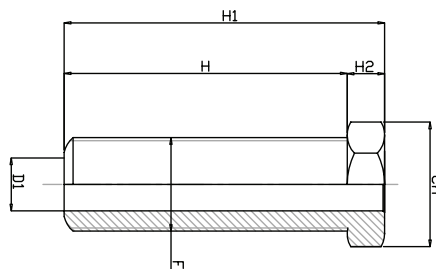

CODICE - CODE		DESCRIZIONE DESCRIPTION	H1	H2	H		D1	F	CARICO STATICO STATIC LOAD NEWTON
ZINCATA	FOSFATATA								
19110Z	19110F	VITE M36x3	135	15	116	41	22	36x3	90000



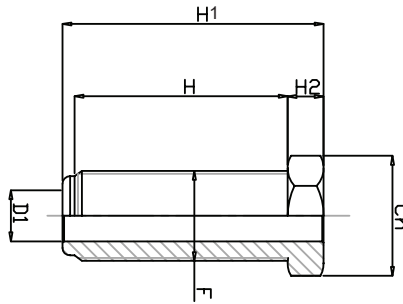

CODICE - CODE		DESCRIZIONE DESCRIPTION	H1	H2	H		D1	F	CARICO STATICO STATIC LOAD NEWTON
ZINCATA	FOSFATATA								
19111Z	19111F	VITE M42x2	140	20	120	45	27	42x2	100000

VITI A REGISTRO IN ACCIAIO STEEL ADJUSTING SCREWS

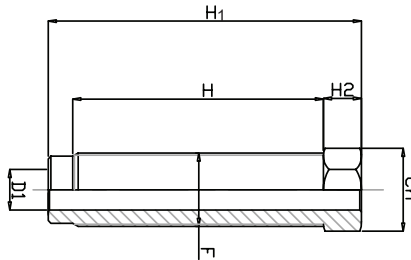

CODICE - CODE		DESCRIZIONE DESCRIPTION	H1	H2	H		D1	F	CARICO STATICO STATIC LOAD NEWTON
ZINCATA FOSFATATA									
19112Z	19112F	VITE M30x2	87	12	70	36	17	30x2	70000



CODICE - CODE		DESCRIZIONE DESCRIPTION	H1	H2	H		D1	F	CARICO STATICO STATIC LOAD NEWTON
ZINCATA FOSFATATA									
19106z	19106F	VITE M27X2	90	12	70	27	15	27x2	65000
19107Z	19107F	VITE M27X2	110	12	91	27	15	27x2	65000
19108Z	19108F	VITE M27X2	125	12	106	27	15	27x2	65000
19109Z	19109F	VITE M27X2	145	12	126	27	15	27x2	65000

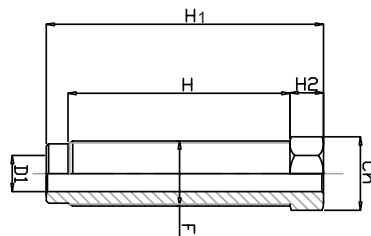

CODICE - CODE		DESCRIZIONE DESCRIPTION	H1	H2	H		D1	F	CARICO STATICO STATIC LOAD NEWTON
ZINCATA FOSFATATA									
19080Z	19080F	VITE M24X2	105	15	85	24	13	24x2	60000
19090Z	19090F	VITE M24X2	160	15	136	24	13	24x2	60000
19102Z	19102F	VITE M35X2	120	15	95	41	22	35x2	90000
19103Z	19103F	VITE M35X2	195	15	170	41	22	35x2	90000
19104Z	19104F	VITE M36X2	120	15	95	41	22	36x2	90000
19105Z	19105F	VITE M36X2	195	15	170	41	22	36x2	90000